

INDUSTRIAL PRODUCTS

Specialists in Anti-Vibration Mountings
and Rubber Engineering Components

Product Catalogue



Acoustiguard - WILREP LTD.

T: 905-625-8944

TOLL FREE: 1-888-625-8944

E: info@wilrep.com

www.acoustiguard.com

| | | | | | | |
|---|--|--|--|--|--|--|
| <p>Cylindrical Bobbins</p> <p>Pages 12–18</p> | | | | | | |
| <p>Buffers & Bump Stops</p> <p>Pages 19–25</p> | | | | | | |
| <p>Captive Transit Mountings</p> <p>Pages 28–32</p> | | | | | | |
| <p>Silent Marine™ Mountings</p> <p>Pages 33–36</p> | | | | | | |
| <p>Flanged Circular & SL Mountings</p> <p>Pages 37–39</p> | | | | | | |
| <p>Turret & Flanged Mountings</p> <p>Pages 40–43</p> | | | | | | |
| <p>Cast Foot, Sandwich & Rail Mountings</p> <p>Pages 45–48</p> | | | | | | |
| <p>Levelling Feet & KG Block</p> <p>Pages 49–52</p> | | | | | | |
| <p>Spring, Hangers & Rope Mountings</p> <p>Pages 53–59</p> | | | | | | |
| <p>Instrument & General Mountings</p> <p>Pages 61–64</p> | | | | | | |
| <p>Instrument & General Mountings</p> <p>Pages 65–67</p> | | | | | | |

INDEX



Industrial Products Ltd

| | | | | | | |
|---|---|---|---|--|---|---|
| <p>Instrument & General Mountings Pages 68–69</p> |  |  |  |  |  |  |
| <p>Instrument & General Mountings Pages 70–75</p> |  |  |  |  |  |  |
| <p>Hydro Mountings Pages 78–82</p> |  |  |  |  |  |  |
| <p>Cone Mountings 2 Hole Pages 83–86</p> |  |  |  |  |  |  |
| <p>Cone Mountings 4 Hole Pages 87–88</p> |  |  |  |  |  |  |
| <p>Cone Mountings Heavy Duty Page 89</p> |  |  |  |  |  |  |
| <p>Compression, CDM & Cab Mountings Pages 90–93</p> |  |  |  |  |  |  |
| <p>SW, Interleaf & Bemag Mountings Pages 94–98</p> |  |  |  |  |  |  |
| <p>Hollow Rubber Springs & Truck Buffer Pads Pages 99–104</p> |  |  |  |  |  |  |
| <p>IOS, Eccentric & Spherical Bushes Pages 105–108</p> |  |  |  |  |  |  |
| <p>Custom & Miscellaneous Pages 109–111</p> |  |  |  |  |  |  |

Anti-Vibration Mounts – ‘What They Are’

The purpose of an AV or Anti-Vibration mounting is to reduce the transmission of excitation forces between a vibrating mass and its foundations or supporting structure. An AV mounting acts as a ‘Spring’ - a device that stores energy & subsequently releases it when the applied force is removed. This released energy can be designed to effectively counteract the imposing forces from an external vibrating motion, thereby reducing the transmitted forces and isolating the vibrating equipment. The key to a successful Anti Vibration mounting is to select the spring so that its speed of response – or ‘natural frequency’ is out of phase with the excitation – ‘forcing frequency’ (this is known as the frequency ratio). AV Industrial Products Ltd’s Engineering Rubber is an extremely effective and highly resilient spring material that can return up to 97% of its stored energy, making it the ideal material for anti-vibration mountings, shock absorbers and rubber springs.

Vibration Engineering – ‘How it works’

Natural Frequency (fn)

When a material or a suspended body is excited, it will vibrate freely with a ‘natural frequency’ or periodicity until it is allowed to come to rest. The ‘frequency’ and ‘Speed’ of the oscillations will be directly proportionate to the spring stiffness, the mass and its inertia.

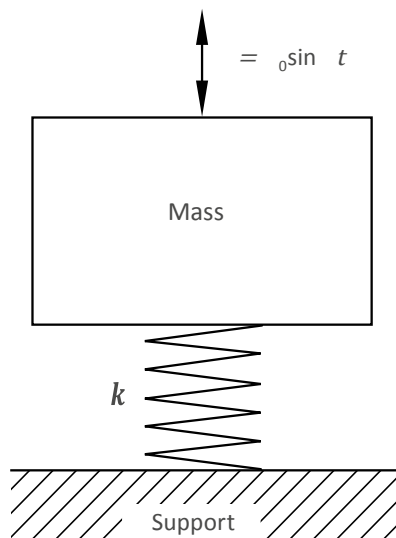

If the mass is freely suspended without any restrictions, it will have 6 modes or directions in which it can oscillate – 3 translational; longitudinal, lateral & vertical and 3 rotational; roll, pitch & yaw (these are known as its 6 degrees of freedom or frequencies).

These frequencies can be ‘coupled’, which means by exciting the body in one direction it is possible that all other modes of vibration can be excited, which is not ideal. By positioning the AV mountings on the principle axis (axis of least resistance) or close to the C of G, decoupling of the frequencies can be achieved. It is therefore important to carry out full analysis of the system to avoid resonance conditions and AV Industrial Products Ltd’s Engineering Department can carry out this analysis for you.

$$f_n = \frac{1}{2\pi} \sqrt{\frac{K}{M}}$$

f_n = Natural Frequency (Hz)
 K = Stiffness (N/m)
 M = Mass (Kg)

Forcing Frequency

If a suspended body is continuously excited, such as an IC engine, the body will oscillate at the frequency at which it’s being excited at. However, depending on the ratio between the forcing frequency or running speed of the engine and the natural frequency of the AV mounting system, (known as the frequency ratio), the forces (i.e. vibration) being transmitted to the support structure can be reduced and isolated. The higher the frequency ratio the greater the isolation.

To ensure that the anti-vibration mountings are providing isolation, the mountings natural frequency must be at least 1.41 times (i.e. $\sqrt{2}$) lower than the forcing frequency, and in practice the running speed should be 2 or 3 times greater than the natural frequency of the mountings.

Calculating the Vibration Isolation

1. Natural Frequency

$$f_n \text{ (CPM)} = \frac{300}{\sqrt{\frac{\text{Mounting Deflection (mm)}}{10}}}$$

2. % Isolation

$$\% \text{ Isolation} = \left[1 - \frac{1}{\left(\frac{\text{Running Speed (RPM)}}{f_n \text{ (CPM)}} \right)^2 - 1} \right] \times 100$$

Resonance

When the natural frequency and the forcing frequency are the same, and therefore the frequency ratio is 1, the direction of the forces will coincide & the system will respond by amplifying the disturbing forces into large oscillations. These destructive forces can cause catastrophic failures of equipment and structures, and must be avoided at all costs. AV Industrial Products Ltd’s Engineering Department can predict these resonance conditions and help prevent costly breakdowns.

Harmonic Order

Internal combustion engines and other rotating machinery have a 'Fundamental' or primary 1st order running speed. This could be continuous, single speed (e.g. 1500RPM) or variable speed (e.g. 800RPM-2000RPM). However, the machine may have various 'Harmonics' or 'Orders' of its primary speed, depending of its construction & configuration. The term 'order' refers to the integer multiple of the fundamental speed. For example, a 4 Stroke 4 cylinder engine will have 2nd order out-of-balance forces due to the reciprocating masses of the pistons & connecting rods, and also 2nd order alternating torque fluctuations caused by the variation in gas pressures during combustion. Example; Running Speed 1500rpm gives a 2nd order vibration of 3000rpm or 50Hz (i.e. 2 x 1500rpm).

When calculating the isolation efficiency of the anti-vibration mounting, the harmonic orders of the engine should be taken into account, as this will increase the frequency ratio and better isolation will be achieved.

Isolator

A support, usually one of many in a system, with the purpose of reducing the transmission of vibration and shock from its foundation or support structure. Also known as an AV mounting or Anti-Vibration mounting.

Damper

This is a device that dissipates energy. In a rubber product the internal Hysteresis or internal molecular friction converts the energy under cyclic deformation into heat. The effect of damping is to increase dynamic stiffness which reduces the frequency ratio and in turn reduced the isolation efficiency of the mounting – see fig 2. That's why the majority of AV mountings are manufactured in natural rubber which has a low static (Ks) to dynamic (Kd) stiffness ratio.

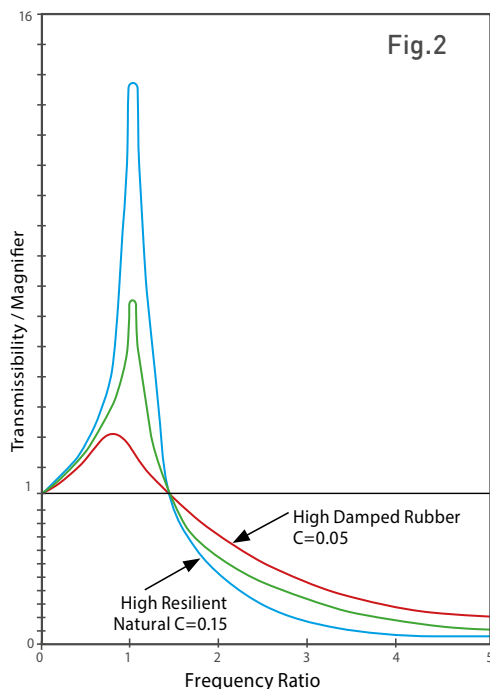

However, some damping is useful to control excessive movements when the equipment passes through its resonance frequency during start-up & shut down, and also to control excessive movements when the out-of-balance forces are high such as a single cylinder engine. For certain applications, additional external damping is introduced by way of a viscous damper, where the damping force is proportional to the velocity of the vibrating mass. AV Hydromounts give the added benefit of high isolation of transmitted forces, and controlling excessive movement or 'shake' at tick-over and low running speeds.

$$\text{Transmissibility \% (Undamped)} = \frac{1}{\sqrt{\left(1 - \left(\frac{fd}{9.55}\right)^2 \cdot \frac{m}{k}\right)^2}} \times 100$$

$$\text{Transmissibility \% (Damped)} = \frac{1}{\sqrt{\left(1 - \left(\frac{fd}{9.55}\right)^2 \cdot \frac{m}{k}\right)^2 + 4 \cdot C^2 \cdot \left(\frac{fd}{9.55}\right) \cdot \frac{m}{k}}} \times 100$$

m = mass (Kg)
k = stiffness (N/m)
fd = Forcing Frequency (RPM)
C = Damping Factor

Rubber - 'What is it'

Versatility

Rubber has amazing properties which can be suited for many applications. By specifying the correct rubber compound, many years of trouble free service life can be achieved. It is an engineering marvel which has been used by humans for 1,000's of years, and still today, rubber is the material which keeps the world flexible.

- Provide isolation from Vibration, Noise and Shock
- Withstand temperatures from -40°C to +300°C
- Self-extinguishing
- Impermeable to gases
- Elongate to 400% its original length
- Can be repeatedly deformed and will return to its original shape
- Resistant to Fuels, Oils, Acids and other hazardous substances
- Moulded into any shape or form
- Electrically insulating
- Resistant to attack from Ozone and Weathering
- Available in many different colours
- FDA approved for medical and food applications

Rubber Hardness

Hardness is a measure of a materials resistance to indentation. The hardness of Rubber is specified using either the 'Shore A' scale or alternatively 'IRHD' – International Rubber Hardness Degree's. Anti-Vibration mountings are available from soft 30sh rubber upto 75sh hard rubber. The hardness of a mounting is directly related to a mountings stiffness.

Stiffness

Stiffness is a measure of the force required to deflect a mounting by a given deflection, and is commonly measured in Kg/mm. Rubber is an incompressible material, much like a fluid, therefore the 'Free Area' of an AV mountings rubber section, known as the shape factor has a considerable influence on the mountings stiffness, in addition to the rubber hardness. The stiffness of a mounting is directly related to its natural frequency.

Creep

Creep is the continuing deformation whilst under static stress and increases with time. However, most of the Creep deformation will take place within the first 48 hours of the load being applied. It is also accelerated with increased temperature.

Compression or 'Permanent' set

When rubber is compressed for a long period of time, it will not fully recover to its original state when the load is removed.

Dynamic Properties

Under repeated cyclic compression of rubber, hysteresis will dissipate some of the energy by converting it into heat. Hysteresis is measured by the difference between the input energy and the energy returned, i.e. the energy loss. Low hysteresis rubber, such as natural rubber provides Low Damping and High Resilience which gives excellent vibration isolation properties. When rubber is subject to cyclic strain, such as vibration, the force required to achieve the same deformation as the static deflection will increase. This increase is known as dynamic stiffness, and the dynamic stiffness is usually 1.1 to 1.4 times higher than the static stiffness for natural rubber, but for some synthetic rubbers this figure can be as high as 8 times.

Rubber Fatigue

Fatigue is defined as 'a change in properties due to load cycling' and it is caused by thermal heat build-up from hysteresis; environmental conditions such as Ozone & Oxygen attack; and mechanical crack propagation, any of which can result in a change in

stiffness, Dynamic growth of cracks and Catastrophic failure. Crack initiation can also occur from small surface defects, moulding defects, edge defects at the bonding interface, and from ingredients such as carbon black which do not fully homogenise with the rubber. The flaws can be as small as 25 to 40 microns and there are usually about 100 flaws per 1cc of rubber.

When natural rubber is strained, crystals form at the tip of the crack, which has a self-reinforcing effect, suppressing further growth of the crack; i.e. if the energy / stress at the tip of the crack is constant, growth stops. If however the load is relaxed and then reapplied crack growth commences again. In non-crystallising rubber such as SBR, EPDM & NBR the rate of crack growth is time dependant, and therefore under a constant load the crack will continue to grow with time unlike natural rubber. For low stressed applications such as engine mountings and radiator mountings, non-crystallising rubbers give perfectly good service life and are commonly used in many applications. However, the importance of strain induced crystallising natural rubber and non-relaxing load cycling is the most important failure mechanism for parts with repeat load cycling such as springs. AV Industrial Products Ltd have developed 'HFP™', a high fatigue resistance Polyisoprene that accommodates the most demanding dynamically fatigued applications.

Manufacturing Methods - 'How its made'

Metal Preparation

Metal components should be degreased prior to the rubber moulding process to ensure optimum bond strength between the rubber and the metal is achieved, and may be followed by grit blasting or a chemical treatment, such as phosphating, to further improve the bonding conditions.

Bonding

Once achieved by electro brass plating, the rubber bonding process is now achieved by applying a chemical adhesive which can be either a single or a two coat system. The chemical adhesive can be applied by hand brushing, dipping, or spraying (including automated spray booths), depending on manufacturing volumes and complexity of metal components. The physical bond between the rubber and metal takes place during the moulding process, where the heat causes a chemical reaction to occur.

Vulcanisation 'curing' of the rubber

Vulcanisation, otherwise known as "Curing", is the process of creating Cross Links between the polymers molecules, which result in a stable thermoset material which can maintain its mechanical properties and will recover its shape after loading (i.e elasticity). The process of Vulcanisation is achieved during the moulding stage where the compounded rubber, including its various additives, such as Sulphur, are subjected to pressure and heat. The term vulcanisation is named after the god 'Vulcan'

Compression Moulding

Compression moulding describes the simplest method of manufacturing for rubber components. Rubber blanks are placed in the cavities of the mould, and pressure is applied to the upper and lower half of the mould. At the same time the mould is heated for a predetermined period of time, during which the rubber is 'Cured' or Vulcanised. The main advantage of compression moulding are the lower costs of the mould tools.

Transfer Injection Moulding

Transfer moulding is similar in some aspects to compression moulding, however with added benefits. Rubber blanks are placed into a transfer pot which sits above the cavities of the mould. Pressure is then applied to a plunger, which in turn forces the rubber into the cavities of the mould via means of transfer holes to form the finished part. It is subject to the same heating process to 'Cure' or Vulcanise the rubber and the process times are comparable to Compression moulding. Due to the better mixing or 'amalgamation' of the rubber, better mechanical properties are achieved, making Transfer moulded parts better for flexing & dynamic applications. Tooling costs tend to be more expensive.

Injection Moulding

Injection moulding involves pre-heating and extruding the rubber so that it can be injected directly into the cavities of a closed mould. The pressure and temperature which the rubber is subjected to is much higher than Compression or Transfer moulding and is closely controlled. Advantages of this process are short manufacturing times and higher output, high quality aesthetic finish, and a fully automated manufacturing system. The main disadvantages are the high cost of mould tooling, long tool change over times, and waste material in the injection system, making it unsuitable for low volume production

Rubber Flash & Trimming

During the moulding process the rubber compound flows around the mould and completely fills the cavity, which forms the shape of the finished component. At the same time, a small amount of rubber may also flow between the split lines in the mould tool, and through any spue release holes. This will result in excess rubber, known as flash, on the surface of the finished component. This rubber flash can be removed by Hand Trimming, Tumbling or Cryogenic Deflashing, to improve the aesthetics of the finished product.

Protective Finishes

It is important that exposed metal parts, particularly when using Carbon Steel, have a protective finish that will protect from the environment and inhibit rust. Untreated metals can result in 'Underbond Corrosion' which will result in reduced bond strength. Common protective finishes include Zinc Plating, Phosphate, Black Etch Primer and Light Oil Coatings.

Inspection & Quality Control

As an ISO9001 accredited company, our philosophy since 1992 has been to provide High Quality engineering components which fully meet specification and achieve the customer's price targets.

Our wealth of experience in the industry, both in the field of Vibration Engineering and Rubber Engineering, allows us to select materials and manufacturing techniques which are best suited for the application in which the product will be used, ensuring our products meet the required specifications at the very best possible prices.

Using state of the art testing equipment, our finished components are carefully inspected during the quality control process using a variety of techniques to ensure they meet the required standards. Our Testing and Inspection facilities includes both destructive and non-destructive techniques to ensure the correct mechanical properties are achieved, including Bond Strength and Stiffness characteristics.

Isolation Chart

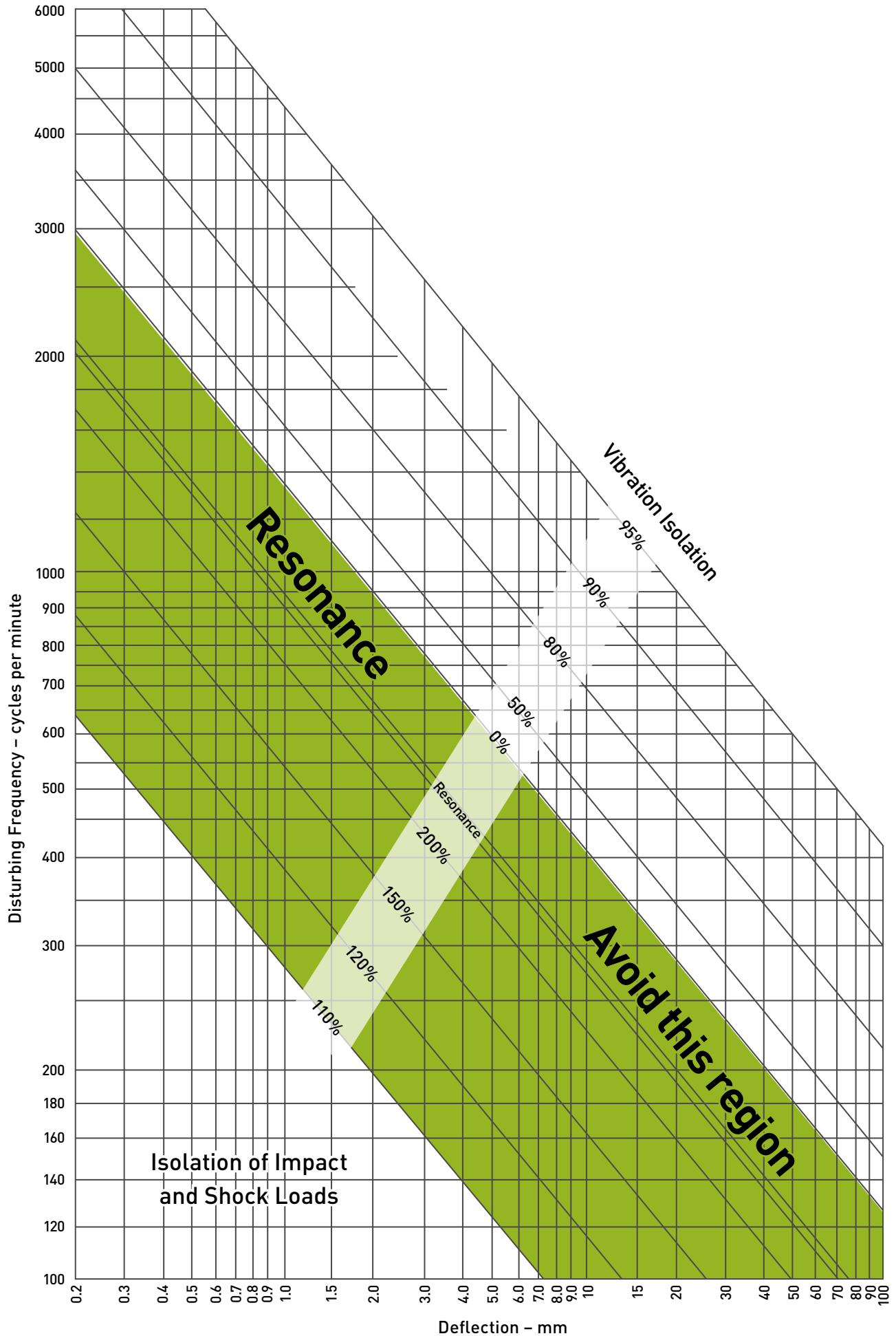



INDUSTRIAL PRODUCTS

Simple 6 Step Guide to Mounting Selection:

1. Determine the total weight of the equipment & number of mountings required
2. Calculate the weight on each mounting (Consider that weight may not be evenly distributed)
3. Determine the running speed (or forcing frequency) of the equipment.
4. Determine the static deflection of the mounting from the chart below (Generally 70% Isolation is acceptable for most applications)

STATIC MOUNTING DEFLECTION REQUIRED TO ACHIEVE ISOLATION

| RUNNING SPEED (RPM) | % VERTICAL ISOLATION REQUIRED | | |
|---------------------|-------------------------------|-------|--------|
| | 70% | 80% | 90% |
| 1000 | 4.0mm | 5.4mm | 10.0mm |
| 1500 | 1.8mm | 2.5mm | 4.5mm |
| 3000 | 0.5mm | 0.7mm | 1.2mm |

5. Based on the load per mounting, select a suitable mounting type to give the required static deflection, taking into account the specific application requirements, such as whether the equipment is Mobile or Static.
6. Ensure that all connections & services to the equipment, such as exhausts, pipework and ducting are flexible in order to allow the equipment to move freely

In addition, other factors that should be taken into account, such as:

- Contamination with Oil, Fuel, Chemicals & extreme Temperatures
- Corrosive Environments – Off Shore Rigs, High Humidity.
- High G forces – Off-Road Vehicles, Construction Plant, Military
- Shock Protection – to protect fragile equipment from drops & impacts.
- Foundation should be Level & Flat. Extra care is required for Suspended Floors
- Suspension Springs to accommodate movement. I.e. Vibratory rollers, compactors, screens
- Low Speed Equipment – Fans, Chillers, Blowers & Air-Conditioning Units.
- Trunion Bushes & Suspension Bushes – Angular & Torsional Movements
- Human Vibration – i.e. ISO 2631
- Mechanical Vibrations – i.e. ISO7919 & ISO10816

We offer a full technical & engineering back up service. If you would like help in selecting suitable mountings for your application, please contact our technical department for assistance.





INDUSTRIAL PRODUCTS

Notes

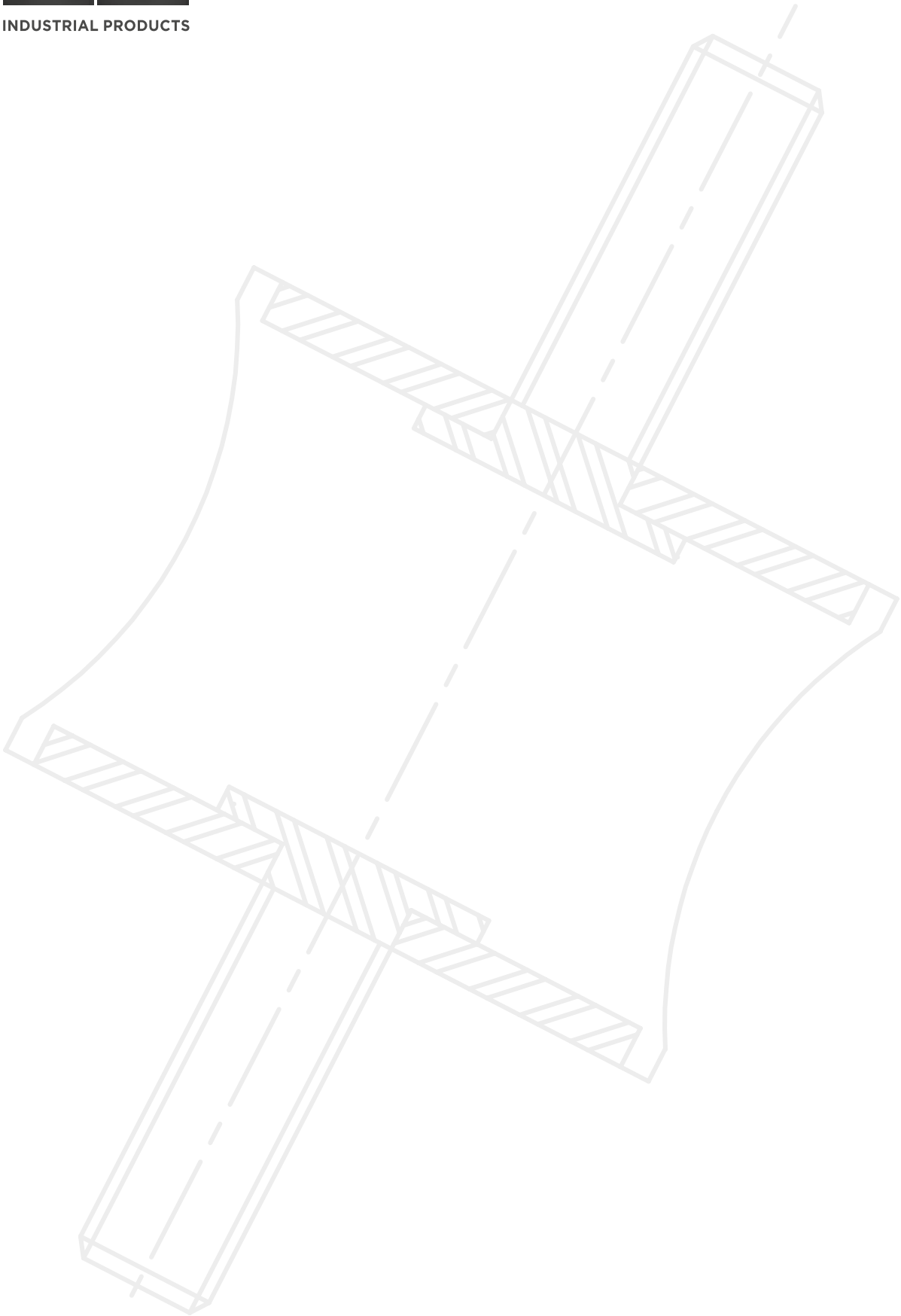

Standard Mountings

Cylindrical Mountings

| | |
|-------------------------------|----|
| Introduction Bobbin Mountings | 12 |
| Male Male Bobbins | 13 |
| Male Female Bobbins | 14 |
| Female Female Bobbins | 15 |
| Waisted Bobbins | 16 |
| Hexagon Bobbins | 17 |
| Profiled Bobbins | 18 |

Buffers and Bump Stops

| | |
|-------------------------------------|----|
| Introduction Buffers and Bump Stops | 19 |
| Male Flat Buffers | 20 |
| Female Flat Buffers | 21 |
| Tapered Buffers | 22 |
| Conical Buffers | 23 |
| Plate Buffers | 24 |
| Square Plate Buffers | 25 |

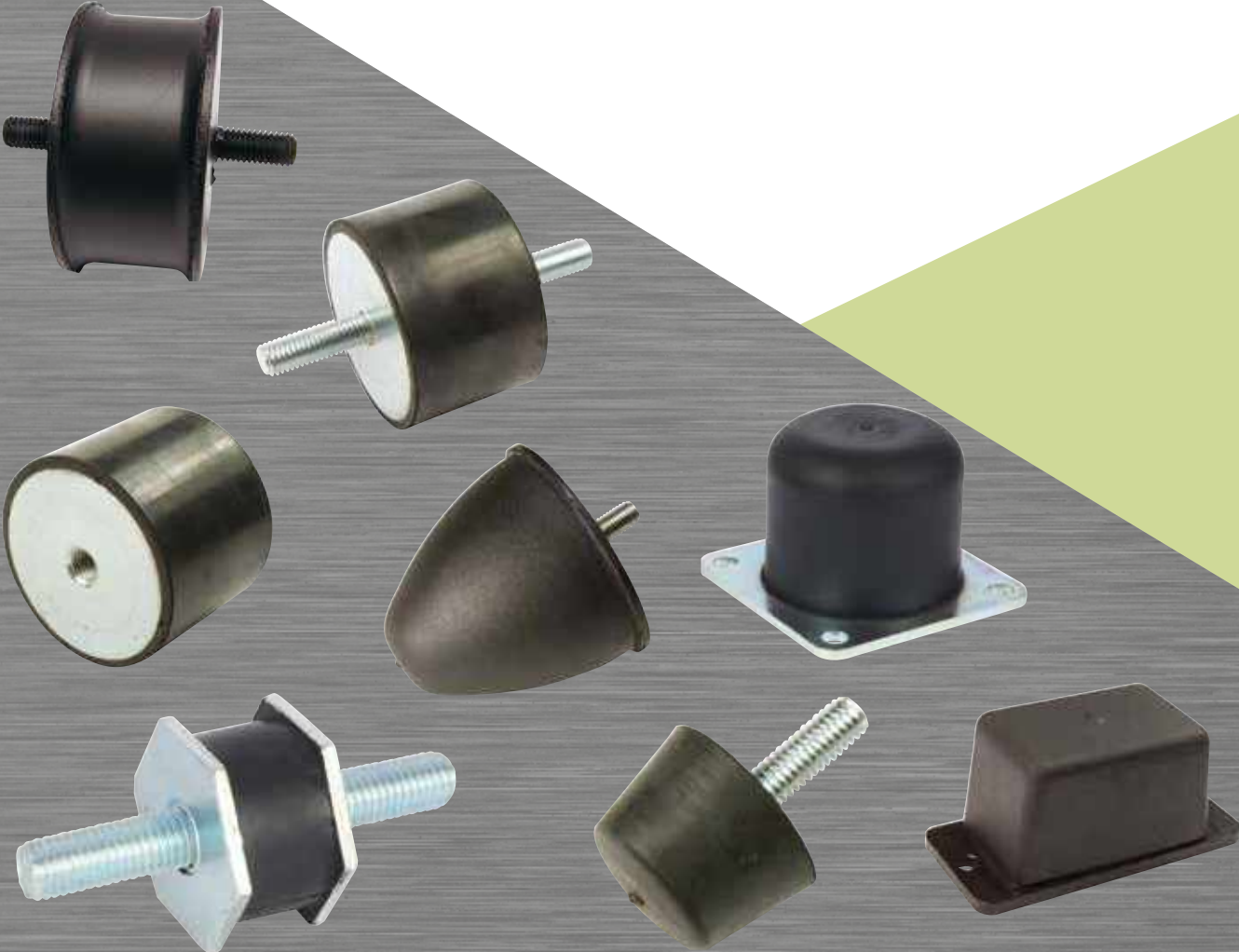

Bobbin Mounts

Bobbin Mounts are a low cost solution to reducing vibration and shock. They can be used in either Compression or Shear or a combination, and are available with various thread configurations.

Advantages:

- Load Range from 1Kg to 2000Kg per mounting
- Zinc Plated Corrosion Resistant metals (RoHS Compliant)
- Ease of Installation
- Excellent Levels of Vibration Absorption
- Low Cost

Additional Sizes, Stainless Steel metals and Oil, Fuel & Heat Resistant rubbers available on request.

Applications:

- Combustion Engines
- General Industrial Machinery
- Generating Sets
- Construction and Agricultural Equipment
- Instruments
- Transit Cases and Shock Packaging

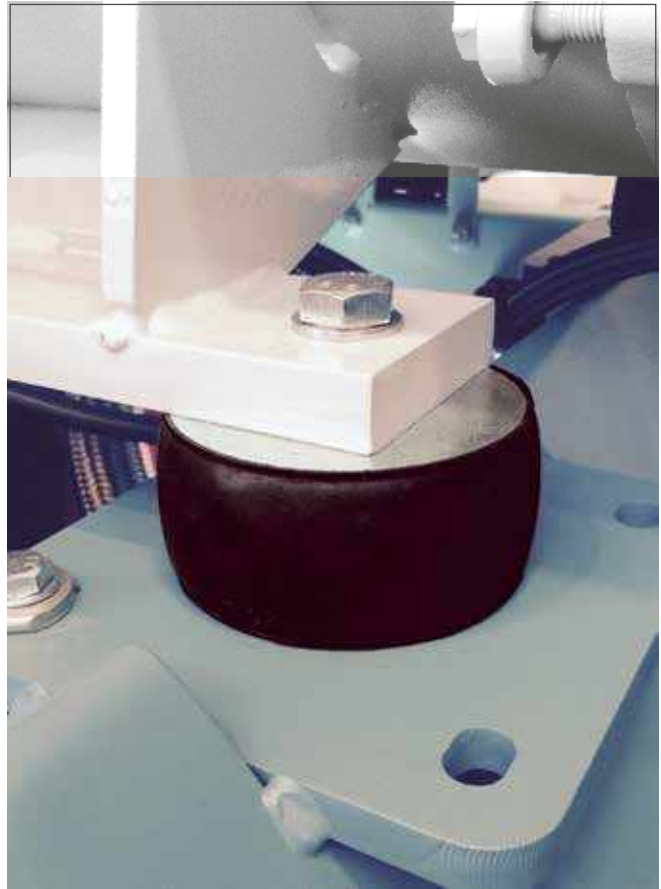

Male Male Bobbins

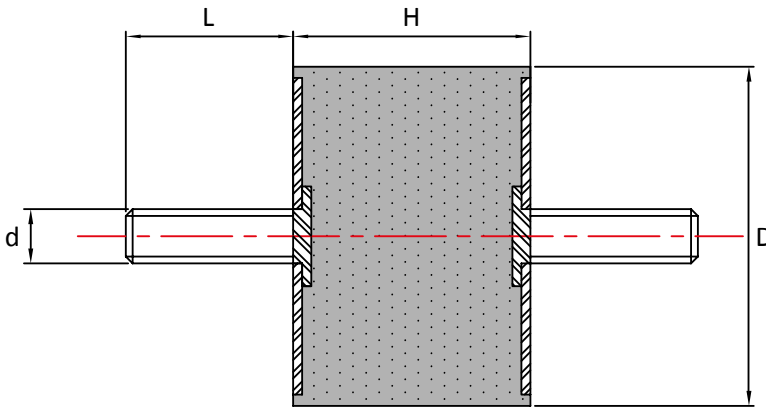

| Part No | D x H | d x L | 45° Shore A | 60° Shore A | 70° Shore A | mm |
|----------|---------|----------|-------------|-------------|-------------|-----|
| 0808MM06 | 08 x 08 | M3 x 06 | 1.8 | 3.3 | 4.5 | 0.6 |
| 1008MM10 | 10 x 08 | M4 x 10 | 2.3 | 4.3 | 6.0 | 0.6 |
| 1010MM10 | 10 x 10 | M4 x 10 | 2.0 | 3.4 | 5.5 | 0.8 |
| 1111MM10 | 11 x 11 | M4 x 10 | 2.1 | 4.5 | 6.0 | 0.5 |
| 1508MM10 | 15 x 08 | M4 x 10 | 7.7 | 14.1 | 19.5 | 0.6 |
| 1510MM10 | 15 x 10 | M4 x 10 | 7 | 14 | 18.5 | 0.8 |
| 1515MM13 | 15 x 15 | M4 x 13 | 5.8 | 10.7 | 15.0 | 1.3 |
| 1515MM15 | 15 x 15 | M5 x 15 | 5.8 | 10.7 | 15.0 | 1.3 |
| 1515MM12 | 15 x 15 | M6 x 12 | 5.8 | 10.7 | 15.0 | 1.3 |
| 1525MM10 | 15 x 25 | M4 x 10 | 2.3 | 5.8 | 7.1 | 2.0 |
| 2008MM18 | 20 x 08 | M6 x 18 | 16.6 | 31.0 | 42.0 | 0.8 |
| 2015MM18 | 20 x 15 | M6 x 18 | 9.0 | 17.0 | 23.0 | 1.2 |
| 2020MM18 | 20 x 20 | M6 x 18 | 7.0 | 13.0 | 18.0 | 1.6 |
| 2025MM18 | 20 x 25 | M6 x 18 | 6.7 | 12.0 | 17.0 | 2.2 |
| 2030MM18 | 20 x 30 | M6 x 18 | 5.3 | 9.6 | 13.5 | 2.6 |
| 2510MM18 | 25 x 10 | M6 x 18 | 25.0 | 48.0 | 66.0 | 0.7 |
| 2515MM18 | 25 x 15 | M6 x 18 | 18.0 | 34.0 | 48.0 | 1.2 |
| 2520MM18 | 25 x 20 | M6 x 18 | 16.0 | 29.0 | 39.0 | 1.6 |
| 2520MM20 | 25 x 20 | M8 x 20 | 16.0 | 29.0 | 39.0 | 1.6 |
| 2522MM20 | 25 x 22 | M8 x 20 | 14.4 | 27.0 | 36.0 | 1.8 |
| 2525MM18 | 25 x 25 | M6 x 18 | 12.4 | 23.0 | 32.0 | 2.1 |
| 2530MM18 | 25 x 30 | M6 x 18 | 11.5 | 22.0 | 29.0 | 2.7 |
| 2530MM20 | 25 x 30 | M8 x 20 | 11.5 | 22.0 | 29.0 | 2.7 |
| 3015MM20 | 30 x 15 | M8 x 20 | 22.0 | 41.0 | 57.0 | 1.1 |
| 3020MM15 | 30 x 20 | M8 x 15 | 20.0 | 38.0 | 51.0 | 1.6 |
| 3020MM20 | 30 x 20 | M8 x 20 | 20.0 | 38.0 | 51.0 | 1.6 |
| 3022MM20 | 30 x 22 | M8 x 20 | 19.0 | 34.0 | 47.0 | 1.8 |
| 3025MM20 | 30 x 25 | M8 x 20 | 17.0 | 29.0 | 40.0 | 2.1 |
| 3030MM20 | 30 x 30 | M8 x 20 | 15.0 | 28.0 | 38.0 | 2.6 |
| 3040MM20 | 30 x 40 | M8 x 20 | 14.0 | 27.0 | 36.0 | 3.6 |
| 4020MM23 | 40 x 20 | M8 x 23 | 41.0 | 77.0 | 106.0 | 1.6 |
| 4020MM25 | 40 x 20 | M10 x 25 | 41.0 | 77.0 | 106.0 | 1.6 |
| 4025MM25 | 40 x 25 | M10 x 25 | 38.0 | 71.0 | 97.0 | 2.1 |
| 4028MM25 | 40 x 28 | M10 x 25 | 35.0 | 65.0 | 89.0 | 2.4 |
| 4030MM23 | 40 x 30 | M8 x 23 | 33.0 | 62.0 | 87.0 | 2.6 |
| 4030MM25 | 40 x 30 | M10 x 25 | 33.0 | 62.0 | 87.0 | 2.6 |
| 4035MM23 | 40 x 35 | M8 x 23 | 30.0 | 56.0 | 78.0 | 3.1 |
| 4035MM25 | 40 x 35 | M10 x 25 | 30.0 | 56.0 | 78.0 | 3.1 |
| 4040MM23 | 40 x 40 | M8 x 23 | 29.0 | 54.0 | 74.0 | 3.6 |
| 4040MM25 | 40 x 40 | M10 x 25 | 29.0 | 54.0 | 74.0 | 3.6 |
| 4045MM25 | 40 x 45 | M10 x 25 | 28.0 | 52.0 | 73.0 | 4.1 |
| 5020MM28 | 50 x 20 | M10 x 28 | 85.0 | 159.0 | 219.0 | 1.5 |

| Part No | D x H | d x L | 45° Shore A | 60° Shore A | 70° Shore A | mm |
|------------|-----------|----------|-------------|-------------|-------------|-----|
| 5025MM25 | 50 x 25 | M10 x 25 | 79.0 | 147.0 | 203.0 | 2.0 |
| 5030MM23 | 50 x 30 | M8 x 23 | 68.0 | 125.0 | 173.0 | 2.5 |
| 5030MM28 | 50 x 30 | M10 x 28 | 68.0 | 125.0 | 173.0 | 2.5 |
| 5035MM25 | 50 x 35 | M10 x 25 | 59.0 | 110.0 | 151.0 | 3.0 |
| 5040MM25 | 50 x 40 | M10 x 25 | 49.0 | 91.0 | 126.0 | 3.5 |
| 5040MM28 | 50 x 40 | M10 x 28 | 49.0 | 91.0 | 126.0 | 3.5 |
| 5045MM25 | 50 x 45 | M10 x 25 | 44.0 | 82.0 | 114.0 | 4.0 |
| 5050MM25 | 50 x 50 | M10 x 25 | 40.0 | 76.0 | 104.0 | 4.5 |
| 6025MM25 | 60 x 25 | M10 x 25 | 122.0 | 227.0 | 314.0 | 2.0 |
| 6030MM25 | 60 x 30 | M10 x 25 | 108.0 | 200.0 | 276.0 | 2.5 |
| 6035MM25 | 60 x 35 | M10 x 25 | 106.0 | 197.0 | 272.0 | 3.1 |
| 6035MM37 | 60 x 35 | M12 x 37 | 106.0 | 197.0 | 272.0 | 3.1 |
| 6040MM25 | 60 x 40 | M10 x 25 | 98.0 | 183.0 | 249.0 | 3.5 |
| 6040MM37 | 60 x 40 | M12 x 37 | 98.0 | 183.0 | 249.0 | 3.5 |
| 6045MM25 | 60 x 45 | M10 x 25 | 89.0 | 166.0 | 230.0 | 4.0 |
| 6045MM37 | 60 x 45 | M12 x 37 | 89.0 | 166.0 | 230.0 | 4.0 |
| 6050MM37 | 60 x 50 | M12 x 37 | 80.0 | 149.0 | 205.0 | 4.5 |
| 6535MM25 | 65 x 35 | M10 x 25 | 129.0 | 240.0 | 332.0 | 3.0 |
| 7030MM25 | 70 x 30 | M10 x 25 | 170.0 | 317.0 | 432.0 | 2.4 |
| 7030MM37 | 70 x 30 | M12 x 37 | 170.0 | 317.0 | 432.0 | 2.4 |
| 7035MM25 | 70 x 35 | M10 x 25 | 150.0 | 298.0 | 411.0 | 2.9 |
| 7035MM37 | 70 x 35 | M12 x 37 | 150.0 | 298.0 | 411.0 | 2.9 |
| 7040MM25 | 70 x 40 | M10 x 25 | 139.0 | 258.0 | 357.0 | 3.4 |
| 7040MM37 | 70 x 40 | M12 x 37 | 139.0 | 258.0 | 357.0 | 3.4 |
| 7045MM25 | 70 x 45 | M10 x 25 | 125.0 | 232.0 | 312.0 | 3.9 |
| 7045MM37 | 70 x 45 | M12 x 37 | 125.0 | 232.0 | 312.0 | 3.9 |
| 7050MM25 | 70 x 50 | M10 x 25 | 114.0 | 211.0 | 292.0 | 4.4 |
| 7050MM37 | 70 x 50 | M12 x 37 | 114.0 | 211.0 | 292.0 | 4.4 |
| 7525MM37 | 75 x 25 | M12 x 37 | 221.0 | 420.0 | 577.0 | 1.9 |
| 7535MM37 | 75 x 35 | M12 x 37 | 170.0 | 340.0 | 470.0 | 2.9 |
| 7540MM37 | 75 x 40 | M12 x 37 | 150.0 | 280.0 | 386.0 | 3.4 |
| 7550MM37 | 75 x 50 | M12 x 37 | 143.0 | 268.0 | 370.0 | 4.4 |
| 7555MM37 | 75 x 55 | M12 x 37 | 125.0 | 235.0 | 324.0 | 4.9 |
| 8030MM35 | 80 x 30 | M14 x 35 | 270.0 | 512.0 | 704.0 | 2.4 |
| 10030MM44 | 100 x 30 | M16 x 44 | 460.0 | 880.0 | 1210.0 | 2.2 |
| 10040MM44 | 100 x 40 | M16 x 44 | 370.0 | 670.0 | 925.0 | 3.2 |
| 10050MM44 | 100 x 50 | M16 x 44 | 290.0 | 525.0 | 725.0 | 4.2 |
| 10055MM44 | 100 x 55 | M16 x 44 | 270.0 | 500.0 | 690.0 | 4.7 |
| 10060MM44 | 100 x 60 | M16 x 44 | 260.0 | 470.0 | 650.0 | 5.2 |
| 10075MM44 | 100 x 75 | M16 x 44 | 215.0 | 380.0 | 525.0 | 6.7 |
| 100100MM44 | 100 x 100 | M16 x 44 | 165.0 | 295.0 | 410.0 | 9.2 |
| 15075MM44 | 150 x 75 | M16 x 44 | 650.0 | 1196.0 | 1651.0 | 6.7 |

Max compression load in Kg deflection in mm.

This information is for guidance only. Customers are recommended to contact us for further technical information on products and applications.

We reserve the right to alter specifications or withdraw products without notice.

Male Female Bobbins

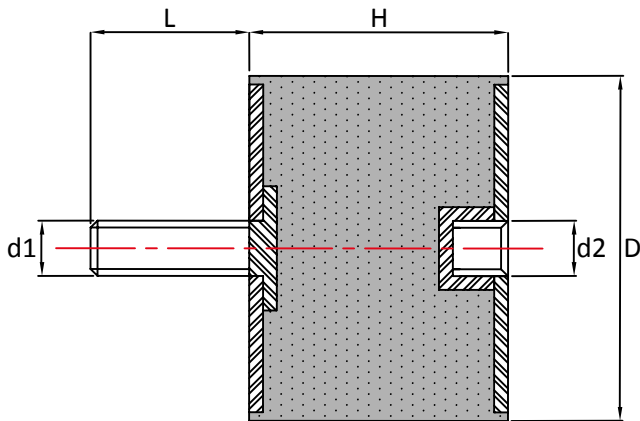

| Part No | D x H | d1 x L | d2 | 45° Shore A | 60° Shore A | 70° Shore A | mm |
|----------|---------|----------|-----|-------------|-------------|-------------|-----|
| 1008MF10 | 10 x 08 | M4 x 10 | M4 | 2.4 | 4.4 | 6.2 | 0.6 |
| 1010MF06 | 10 x 10 | M4 x 06 | M4 | 2.1 | 4.0 | 5.5 | 0.8 |
| 1513MF10 | 15 x 13 | M4 x 10 | M4 | 4.0 | 7.8 | 10.8 | 1.1 |
| 1515MF10 | 15 x 15 | M4 x 10 | M4 | 6.0 | 11.0 | 15.4 | 1.3 |
| 2015MF18 | 20 x 15 | M6 x 18 | M6 | 9.3 | 17.5 | 24.0 | 1.2 |
| 2020MF18 | 20 x 20 | M6 x 18 | M6 | 7.2 | 13.4 | 18.5 | 1.6 |
| 2025MF18 | 20 x 25 | M6 x 18 | M6 | 6 | 12 | 17.5 | 2.1 |
| 2030MF18 | 20 x 30 | M6 x 18 | M6 | 5.5 | 9.9 | 13.9 | 2.6 |
| 2515MF18 | 25 x 15 | M6 x 18 | M6 | 18.5 | 35.0 | 49.0 | 1.2 |
| 2520MF20 | 25 x 20 | M8 x 20 | M8 | 16.5 | 30.0 | 40.0 | 1.6 |
| 2525MF18 | 25 x 25 | M6 x 18 | M6 | 12.8 | 24.0 | 33.0 | 2.1 |
| 2530MF20 | 25 x 30 | M8 x 20 | M8 | 11.8 | 23.0 | 30.0 | 2.7 |
| 3015MF20 | 30 x 15 | M8 x 20 | M8 | 23.0 | 42.0 | 59.0 | 1.1 |
| 3020MF20 | 30 x 20 | M8 x 20 | M8 | 21.0 | 39.0 | 53.0 | 1.6 |
| 3025MF20 | 30 x 25 | M8 x 20 | M8 | 17.5 | 30.0 | 41.0 | 2.1 |
| 3030MF20 | 30 x 30 | M8 x 20 | M8 | 15.5 | 29.0 | 39.0 | 2.6 |
| 3040MF20 | 30 x 40 | M8 x 20 | M8 | 14.5 | 28.0 | 37.0 | 3.6 |
| 4020MF23 | 40 x 20 | M8 x 23 | M8 | 42.0 | 79.0 | 109.0 | 1.6 |
| 4020MF25 | 40 x 20 | M10 x 25 | M10 | 42.0 | 79.0 | 109.0 | 1.6 |
| 4025MF20 | 40 x 25 | M8 x 20 | M8 | 39.0 | 73.0 | 100.0 | 2.1 |
| 4030MF23 | 40 x 30 | M8 x 23 | M8 | 34.0 | 64.0 | 89.0 | 2.6 |
| 4030MF25 | 40 x 30 | M10 x 25 | M10 | 34.0 | 64.0 | 89.0 | 2.6 |
| 4035MF23 | 40 x 35 | M8 x 23 | M8 | 31.0 | 57.0 | 80.0 | 3.1 |
| 4035MF25 | 40 x 35 | M10 x 25 | M10 | 31.0 | 57.0 | 80.0 | 3.1 |
| 4040MF20 | 40 x 40 | M8 x 20 | M8 | 30.0 | 55.0 | 76.0 | 3.6 |
| 4040MF25 | 40 x 40 | M10 x 25 | M10 | 30.0 | 55.0 | 76.0 | 3.6 |
| 5020MF28 | 50 x 20 | M10 x 28 | M10 | 87.0 | 164.0 | 226.0 | 1.5 |
| 5025MF25 | 50 x 25 | M10 x 25 | M10 | 81.0 | 151.0 | 209.0 | 2.0 |
| 5030MF25 | 50 x 30 | M10 x 25 | M10 | 70.0 | 129.0 | 178.0 | 2.5 |
| 5035MF25 | 50 x 35 | M10 x 25 | M10 | 61.0 | 113.0 | 156.0 | 3.0 |
| 5040MF25 | 50 x 40 | M10 x 25 | M10 | 50.0 | 94.0 | 130.0 | 3.5 |

| Part No | D x H | d1 x L | d2 | 45° Shore A | 60° Shore A | 70° Shore A | mm |
|------------|-----------|----------|-----|-------------|-------------|-------------|-----|
| 5045MF28 | 50 x 45 | M10 x 28 | M10 | 45.0 | 84.0 | 117.0 | 4.0 |
| 5050MF25 | 50 x 50 | M10 x 25 | M10 | 41.0 | 78.0 | 107.0 | 4.5 |
| 6025MF25 | 60 x 25 | M10 x 25 | M10 | 126.0 | 234.0 | 323.0 | 2.0 |
| 6030MF25 | 60 x 30 | M10 x 25 | M10 | 111.0 | 206.0 | 284.0 | 2.5 |
| 6036MF25 | 60 x 36 | M10 x 25 | M10 | 109.0 | 203.0 | 280.0 | 3.1 |
| 6036MF37 | 60 x 36 | M12 x 37 | M12 | 109.0 | 203.0 | 280.0 | 3.1 |
| 6040MF25 | 60 x 40 | M10 x 25 | M10 | 101.0 | 188.0 | 256.0 | 3.5 |
| 6040MF37 | 60 x 40 | M12 x 37 | M12 | 101.0 | 188.0 | 256.0 | 3.5 |
| 6045MF25 | 60 x 45 | M10 x 25 | M10 | 92.0 | 171.0 | 237.0 | 4.0 |
| 6535MF25 | 65 x 35 | M10 x 25 | M10 | 133.0 | 247.0 | 342.0 | 3.0 |
| 6540MF37 | 65 x 40 | M12 x 37 | M12 | 118.0 | 216.0 | 298.0 | 3.5 |
| 6545MF37 | 65 x 45 | M12 x 37 | M12 | 103.0 | 190.0 | 264.0 | 4.0 |
| 6550MF37 | 65 x 50 | M12 x 37 | M12 | 88.0 | 163.0 | 226.0 | 4.5 |
| 7030MF37 | 70 x 30 | M12 x 37 | M12 | 175.0 | 326.0 | 445.0 | 2.4 |
| 7040MF25 | 70 x 40 | M10 x 25 | M10 | 143.0 | 266.0 | 367.0 | 3.4 |
| 7040MF37 | 70 x 40 | M12 x 37 | M12 | 143.0 | 266.0 | 367.0 | 3.4 |
| 7045MF25 | 70 x 45 | M10 x 25 | M10 | 129.0 | 239.0 | 321.0 | 3.9 |
| 7045MF37 | 70 x 45 | M12 x 37 | M12 | 129.0 | 239.0 | 321.0 | 3.9 |
| 7050MF37 | 70 x 50 | M12 x 37 | M12 | 117.0 | 217.0 | 300.0 | 4.4 |
| 7060MF37 | 70 x 60 | M12 x 37 | M12 | 116.0 | 214.0 | 296.0 | 5.4 |
| 7525MF37 | 75 x 25 | M12 x 37 | M12 | 221.0 | 420.0 | 577.0 | 1.9 |
| 7540MF37 | 75 x 40 | M12 x 37 | M12 | 154.0 | 288.0 | 397.0 | 3.4 |
| 7550MF37 | 75 x 50 | M12 x 37 | M12 | 147.0 | 276.0 | 381.0 | 4.4 |
| 7555MF37 | 75 x 55 | M12 x 37 | M12 | 128.0 | 242.0 | 333.0 | 4.9 |
| 10050MF44 | 100 x 50 | M16 x 44 | M16 | 300.0 | 540.0 | 750.0 | 4.2 |
| 10055MF44 | 100 x 55 | M16 x 44 | M16 | 275.0 | 515.0 | 710.0 | 4.7 |
| 10060MF44 | 100 x 60 | M16 x 44 | M16 | 265.0 | 480.0 | 670.0 | 5.2 |
| 10075MF44 | 100 x 75 | M16 x 44 | M16 | 220.0 | 390.0 | 540.0 | 6.7 |
| 100100MF44 | 100 x 100 | M16 x 44 | M16 | 170.0 | 300.0 | 420.0 | 9.2 |
| 12555MF44 | 125 x 55 | M16 x 44 | M16 | 400.0 | 800.0 | 1150.0 | 4.7 |
| 15055MF41 | 150 x 55 | M16 x 41 | M16 | 505.0 | 920.0 | 1296.0 | 4.7 |
| 15075MF44 | 150 x 75 | M16 x 44 | M16 | 400.0 | 720.0 | 1000.0 | 6.7 |

Max compression load in Kg deflection in mm.

This information is for guidance only. Customers are recommended to contact us for further technical information on products and applications.

We reserve the right to alter specifications or withdraw products without notice.

Female Female Bobbins

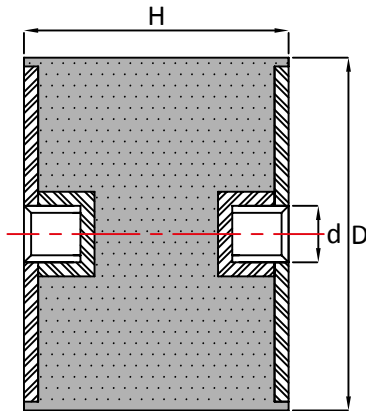

| Part No | D x H | d | 45° Shore A | 60° Shore A | 70° Shore A | mm |
|----------|---------|-----|-------------|-------------|-------------|-----|
| 1515FF04 | 15 x 15 | M4 | 6.1 | 11.2 | 15.8 | 1.3 |
| 2015FF06 | 20 x 15 | M6 | 7.9 | 14.8 | 20.5 | 1.0 |
| 2020FF06 | 20 x 20 | M6 | 7.4 | 13.7 | 18.9 | 1.6 |
| 2025FF06 | 20 x 25 | M6 | 7.0 | 12.6 | 17.8 | 2.2 |
| 2030FF06 | 20 x 30 | M6 | 5.6 | 10.0 | 14.1 | 2.6 |
| 2515FF06 | 25 x 15 | M6 | 15.7 | 30.0 | 42.0 | 1.0 |
| 2520FF06 | 25 x 20 | M6 | 16.8 | 31.0 | 41.0 | 1.6 |
| 2525FF06 | 25 x 25 | M6 | 13.0 | 25.0 | 34.0 | 2.1 |
| 2525FF08 | 25 x 25 | M8 | 13.0 | 25.0 | 34.0 | 2.1 |
| 2530FF08 | 25 x 30 | M8 | 10.4 | 20.7 | 30.4 | 2.6 |
| 3020FF08 | 30 x 20 | M8 | 15.7 | 30.0 | 40.0 | 1.2 |
| 3025FF08 | 30 x 25 | M8 | 18.0 | 31.0 | 42.0 | 2.1 |
| 3030FF08 | 30 x 30 | M8 | 15.8 | 30.0 | 40.0 | 2.6 |
| 3035FF08 | 30 x 35 | M8 | 15.0 | 29.0 | 39.0 | 3.1 |
| 3040FF08 | 30 x 40 | M8 | 14.7 | 29.0 | 38.0 | 3.6 |
| 4020FF08 | 40 x 20 | M8 | 32.0 | 61.0 | 88.0 | 1.2 |
| 4030FF08 | 40 x 30 | M8 | 35.0 | 65.0 | 91.0 | 2.6 |
| 4030FF10 | 40 x 30 | M10 | 35.0 | 65.0 | 91.0 | 2.6 |
| 4035FF08 | 40 x 35 | M8 | 27.0 | 54.0 | 79.0 | 2.5 |
| 4035FF10 | 40 x 35 | M10 | 27.0 | 54.0 | 79.0 | 2.5 |
| 4040FF08 | 40 x 40 | M8 | 31.0 | 57.0 | 78.0 | 3.6 |
| 4040FF10 | 40 x 40 | M10 | 31.0 | 57.0 | 78.0 | 3.6 |
| 4045FF10 | 40 x 45 | M10 | 30.0 | 56.0 | 77.0 | 4.1 |
| 5025FF10 | 50 x 25 | M10 | 76.0 | 140.0 | 193.0 | 2.1 |
| 5030FF10 | 50 x 30 | M10 | 71.0 | 131.0 | 180.0 | 2.5 |
| 5035FF10 | 50 x 35 | M10 | 62.0 | 115.0 | 158.0 | 3.0 |
| 5040FF10 | 50 x 40 | M10 | 51.0 | 95.0 | 132.0 | 3.5 |
| 5045FF08 | 50 x 45 | M8 | 46.0 | 86.0 | 120.0 | 4.0 |
| 5045FF10 | 50 x 45 | M10 | 46.0 | 86.0 | 120.0 | 4.0 |
| 5050FF10 | 50 x 50 | M10 | 42.0 | 86.0 | 109.0 | 4.5 |
| 5060FF10 | 50 x 60 | M10 | 38.0 | 80.0 | 105.0 | 5.4 |
| 6035FF12 | 60 x 35 | M12 | 111.0 | 260.0 | 285.0 | 3.1 |

| Part No | D x H | d | 45° Shore A | 60° Shore A | 70° Shore A | mm |
|------------|-----------|-----|-------------|-------------|-------------|-----|
| 6040FF10 | 60 x 40 | M10 | 103.0 | 192.0 | 261.0 | 3.5 |
| 6040FF12 | 60 x 40 | M12 | 103.0 | 192.0 | 261.0 | 3.5 |
| 6045FF10 | 60 x 45 | M10 | 93.0 | 174.0 | 241.0 | 4.0 |
| 6045FF12 | 60 x 45 | M12 | 93.0 | 174.0 | 241.0 | 4.0 |
| 6050FF12 | 60 x 50 | M12 | 84.0 | 156.0 | 215.0 | 4.5 |
| 6535FF12 | 65 x 35 | M12 | 135.0 | 252.0 | 348.0 | 3.0 |
| 7030FF10 | 70 x 30 | M10 | 178.0 | 330.0 | 450.0 | 2.4 |
| 7035FF10 | 70 x 35 | M10 | 157.0 | 312.0 | 430.0 | 2.9 |
| 7035FF12 | 70 x 35 | M12 | 157.0 | 312.0 | 430.0 | 2.9 |
| 7040FF10 | 70 x 40 | M10 | 145.0 | 270.0 | 375.0 | 3.4 |
| 7045FF10 | 70 x 45 | M10 | 130.0 | 240.0 | 327.0 | 3.9 |
| 7045FF12 | 70 x 45 | M12 | 130.0 | 240.0 | 327.0 | 3.9 |
| 7050FF10 | 70 x 50 | M10 | 120.0 | 220.0 | 305.0 | 4.4 |
| 7050FF12 | 70 x 50 | M12 | 120.0 | 220.0 | 305.0 | 4.4 |
| 7060FF12 | 70 x 60 | M12 | 118.0 | 218.0 | 300.0 | 5.4 |
| 7070FF10 | 70 x 70 | M10 | 113.0 | 210.0 | 290.0 | 6.4 |
| 7540FF12 | 75 x 40 | M12 | 157.0 | 290.0 | 400.0 | 3.4 |
| 7545FF12 | 75 x 45 | M12 | 155.0 | 285.0 | 392.0 | 3.9 |
| 7550FF12 | 75 x 50 | M12 | 150.0 | 280.0 | 390.0 | 4.4 |
| 7555FF12 | 75 x 55 | M12 | 130.0 | 245.0 | 340.0 | 4.9 |
| 7560FF12 | 75 x 60 | M12 | 115.0 | 190.0 | 300.0 | 5.2 |
| 9575FF12 | 95 x 75 | M12 | 225.0 | 450.0 | 661.5 | 6.7 |
| 9575FF16 | 95 x 75 | M16 | 225.0 | 450.0 | 661.5 | 6.7 |
| 10040FF16 | 100 x 40 | M16 | 390.0 | 700.0 | 970.0 | 3.2 |
| 10045FF16 | 100 x 45 | M16 | 345.0 | 625.0 | 865.0 | 3.7 |
| 10050FF16 | 100 x 50 | M16 | 305.0 | 550.0 | 760.0 | 4.2 |
| 10055FF16 | 100 x 55 | M16 | 280.0 | 520.0 | 720.0 | 4.7 |
| 10060FF16 | 100 x 60 | M16 | 270.0 | 490.0 | 680.0 | 5.2 |
| 100100FF16 | 100 x 100 | M16 | 175.0 | 305.0 | 430.0 | 9.2 |
| 10575FF16 | 105 x 75 | M16 | 325 | 650 | 955.5 | 6.7 |
| 12075FF16 | 120 x 75 | M16 | 390 | 780 | 1146.6 | 6.7 |
| 15075FF20 | 150 x 75 | M20 | 405.0 | 725.0 | 1010.0 | 6.7 |

Max compression load in Kg deflection in mm.

This information is for guidance only. Customers are recommended to contact us for further technical information on products and applications.

We reserve the right to alter specifications or withdraw products without notice.

Waisted Bobbins

Waisted bobbin mountings are ideal for applications where the predominant force or vibration is in the lateral direction.

By design, the waisted bobbins provide a low shear stiffness which provides more deflection and an increased level of vibration reduction in the lateral direction.

Applications include:

Lightweight Equipment; Vibratory Feeders; Electric Motors; Control Panels; Measuring Apparatus

Also available in Male Female and Female Female stud configurations.

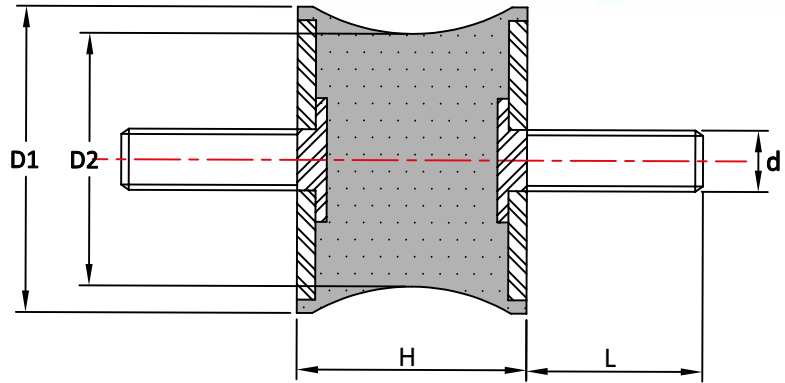

| Part No | D1 | D2 | H | d | L |
|-----------------|-----|-----|----|-----|----|
| 1008WMM06 | 10 | 4.5 | 8 | M3 | 6 |
| 1010WMM10 | 10 | 8 | 10 | M4 | 10 |
| 1214WMM10 | 12 | 7 | 14 | M4 | 10 |
| 15/8.5/15WMM10 | 15 | 8.5 | 15 | M4 | 10 |
| 15/12/15WMM10 | 15 | 12 | 15 | M4 | 10 |
| 15/12/15WMM12 | 15 | 12 | 15 | M6 | 12 |
| 2015WMM10 | 20 | 14 | 15 | M4 | 10 |
| 2019WMM18 | 20 | 14 | 19 | M6 | 18 |
| 20/12/30WMM18 | 20 | 12 | 30 | M6 | 18 |
| 20/14/30WMM10 | 20 | 14 | 30 | M4 | 10 |
| 25/17/20WMM18 | 25 | 17 | 20 | M6 | 18 |
| 25/18/20WMM23 | 25 | 18 | 20 | M8 | 23 |
| 30/22/20WMM23 | 30 | 22 | 20 | M8 | 23 |
| 30/24/25WMM20 | 30 | 24 | 25 | M8 | 20 |
| 30/25/20WMM23 | 30 | 25 | 20 | M8 | 23 |
| 3025WMM15 | 30 | 18 | 25 | M6 | 15 |
| 3041WMM20 | 30 | 20 | 41 | M8 | 20 |
| WMM1380 | 35 | 24 | 34 | M8 | 20 |
| 40/25/30WMM23 | 40 | 25 | 30 | M8 | 23 |
| 40/33/30WMM23 | 40 | 33 | 30 | M8 | 23 |
| 4048WMM23 | 40 | 20 | 48 | M8 | 23 |
| 4625WMM28 | 46 | 40 | 25 | M10 | 28 |
| 5030WMM28 | 50 | 42 | 30 | M10 | 28 |
| WMM2312 | 54 | 42 | 36 | M10 | 25 |
| 5545WMM28 | 55 | 44 | 45 | M8 | 28 |
| 57/25/44WMM28 | 57 | 25 | 44 | M10 | 28 |
| 57/44/45WMM28 | 57 | 44 | 45 | M10 | 28 |
| 57/25/45WMM20 | 57 | 25 | 45 | M8 | 20 |
| 60/34/44WMM20 | 60 | 34 | 44 | M8 | 20 |
| 6060WMM28 | 60 | 49 | 60 | M10 | 28 |
| 7053WMM28 | 70 | 45 | 53 | M12 | 28 |
| 9575WMM41 | 95 | 80 | 75 | M16 | 41 |
| 180/148/75WMM34 | 180 | 148 | 75 | M20 | 34 |
| 180/150/75WMM45 | 180 | 150 | 75 | M20 | 45 |

Max compression load in Kg deflection in mm.

This information is for guidance only. Customers are recommended to contact us for further technical information on products and applications.

We reserve the right to alter specifications or withdraw products without notice.

Hexagon Bobbins

Hexagon Bobbin Mounts are manufactured with hexagonal end metals to allow the fitter to grip the mounting with a spanner to avoid twisting of the rubber during installation.

Mountings can be used in Compression, Shear or a combination of both and can accommodate compression loads from 4kg to 110kg per mounting.

Applications include:

Control Panels; Industrial Equipment; Radiators;
Exhaust Systems and General purpose machinery.

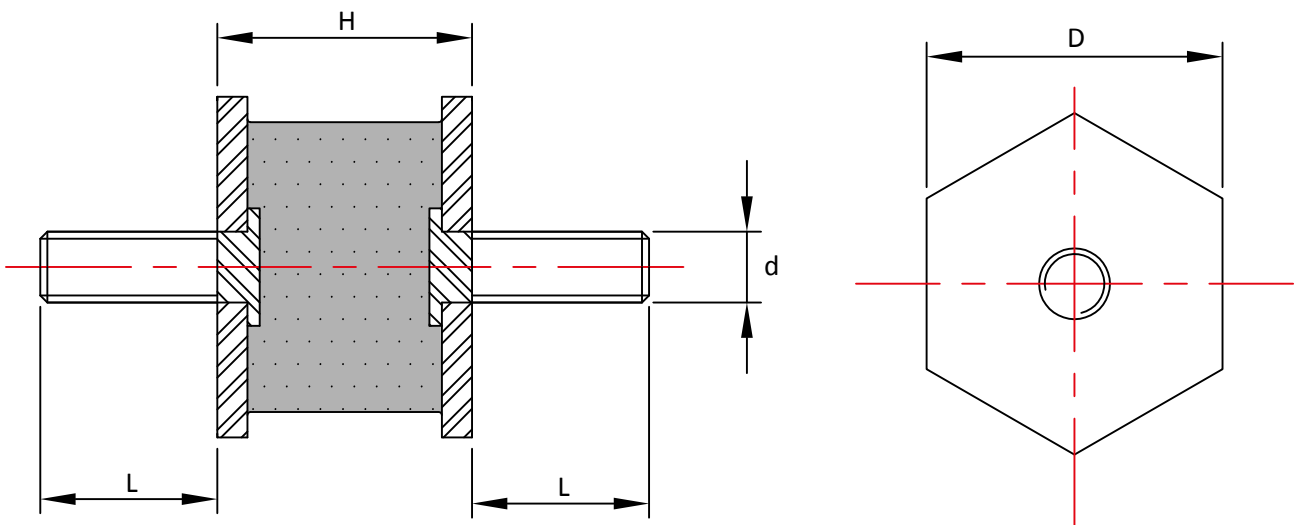

| Part No | D | H | d | L | Compression Load | | Shear Load | |
|------------|----|----|-----|----|------------------|-----|------------|-----|
| | | | | | Kg | mm | Kg | mm |
| HEX1382/45 | 16 | 16 | M6 | 12 | 4.0 | 1.0 | 3 | 3.8 |
| HEX1382/60 | 16 | 16 | M6 | 12 | 8.0 | 1.0 | 3.2 | 1.8 |
| HEX1383/45 | 21 | 19 | M8 | 20 | 8.0 | 1.2 | 7.0 | 6.5 |
| HEX1383/60 | 21 | 19 | M8 | 20 | 16.0 | 1.2 | 6.5 | 2.7 |
| HEX1384/45 | 32 | 26 | M8 | 16 | 16.0 | 2.0 | 10.0 | 7.0 |
| HEX1384/60 | 32 | 26 | M8 | 16 | 31.0 | 2.0 | 11.0 | 3.5 |
| HEX1385/45 | 33 | 22 | M10 | 25 | 29.0 | 1.5 | 13.0 | 4.5 |
| HEX1385/60 | 33 | 22 | M10 | 25 | 57.0 | 1.5 | 14.0 | 2.5 |
| HEX1386/45 | 43 | 25 | M12 | 30 | 58.0 | 1.7 | 28.0 | 6.0 |
| HEX1386/60 | 43 | 25 | M12 | 30 | 110.0 | 1.7 | 30.0 | 3.0 |
| HEX200/60 | 32 | 23 | M8 | 18 | 36.0 | 1.5 | 13.0 | 3.5 |

Max compression load in Kg deflection in mm.

This information is for guidance only. Customers are recommended to contact us for further technical information on products and applications. We reserve the right to alter specifications or withdraw products without notice.

Profiled Bobbins

Profiled Bobbin Mounts are ideal for applications where high dynamic forces are applied, particularly when being used in Shear or Shear Compression. The oversized end metals allow for an improved bonded interface between the rubber and metal, increasing the fatigue life when the parts are used for high dynamic applications.



Advantages

- Improved Fatigue Life
- Ideal for High Dynamic Applications
- Ease of Installation
- Corrosion Resistant Zinc Plated Metals

Applications

- Vibratory Rollers and Compactors
- Sieves and Grading Equipment
- Industrial Machinery
- General Construction Equipment

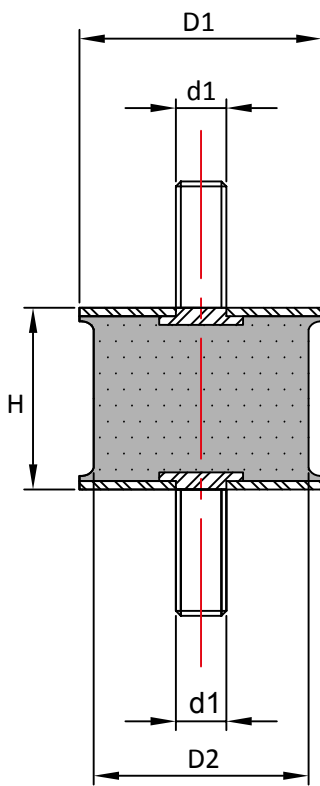

Type 1 - Male Male

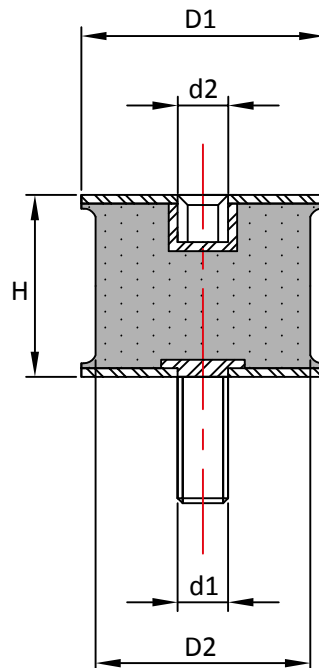

Type 2 - Male Female

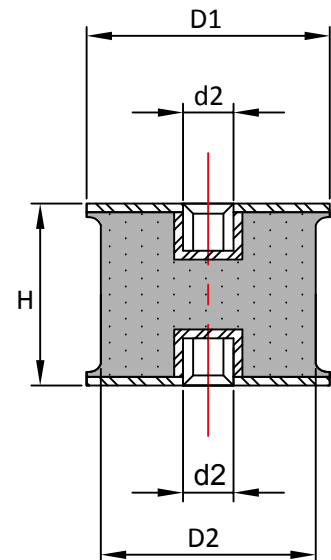

Type 3 - Female Female

| Part No | D1 | D2 | H | Type 1 | | Type 2 | | Type 3 | | Maximum Compression Load (kg) | | |
|-----------|-----|----|----|--------|--------|--------|-----|--------|-----|-------------------------------|-------------|-------------|
| | | | | d1 | d1 | d1 | d2 | d2 | d2 | 45° Shore A | 60° Shore A | 70° Shore A |
| PR262222 | 26 | 22 | 22 | M8x10 | M8x18 | M8x18 | M8 | M8 | M8 | 7 | 13 | 18 |
| PR403528 | 40 | 35 | 28 | M10x16 | M10x20 | M10x20 | M10 | M10 | M10 | 20 | 40 | 62 |
| PR464025 | 46 | 40 | 25 | M10x28 | M10x28 | M10x28 | M10 | M10 | M10 | 38 | 71 | 97 |
| PR757040 | 75 | 70 | 40 | M12x37 | M12x37 | M12x37 | M12 | M12 | M12 | 139 | 258 | 357 |
| PR1009555 | 100 | 95 | 55 | M16x41 | M16x41 | M16x41 | M16 | M16 | M16 | 270 | 500 | 690 |
| PR1009575 | 100 | 95 | 75 | M16x45 | M16x45 | M16x45 | M16 | M16 | M16 | 215 | 380 | 525 |

Max compression load in Kg deflection in mm.

This information is for guidance only. Customers are recommended to contact us for further technical information on products and applications. We reserve the right to alter specifications or withdraw products without notice.

Buffers and Bump Stops

Buffers and Bump Stops provide a low cost solution for absorbing Shock and Vibration. They are easy to install, and typically used to reduce the force of an impact from a secondary object. Alternatively they can be used as an elastic element, where the rubber remains in direct contact with a surface.

They are manufactured from 1st Grade Natural Rubber which can accommodate high deformation and high stresses. On request, they are also available in High Damped Rubber.

Advantages:

- Absorb Impact Shock Forces
- Reduce Shock induced Stress on Fabrications
- Eliminate Metal to Metal Contact
- Provide Overload Protection
- Additional Sizes, Stainless Steel metals and Oil, Fuel & Heat Resistant rubbers available on request.

Buffers and Bumps Stops are available in various configurations, including: Flat Buffers; Conical Buffers and Plate Buffers.

Applications:

- Construction Equipment
- General Industrial machinery
- Agricultural Machinery and Equipment
- Commercial Vehicle
- Lifts and Elevators



Male Flat Buffer

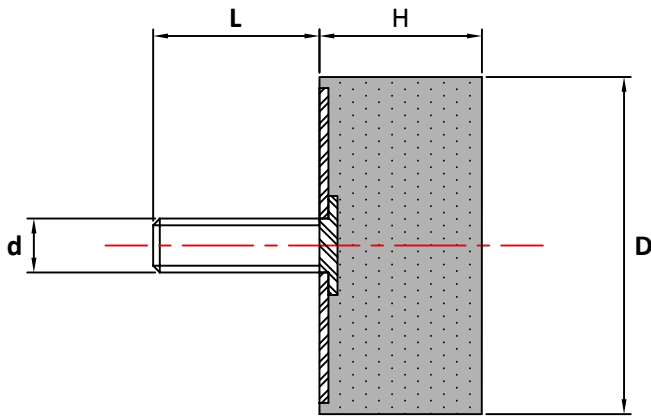

| Part No | D x H | d x L | 45° Shore A | 60° Shore A | 70° Shore A | mm |
|-----------|---------|----------|-------------|-------------|-------------|------|
| 0808MFB06 | 08 x 08 | M3 x 06 | 7.5 | 10.5 | 15.0 | 2.0 |
| 1008MFB10 | 10 x 08 | M4 x 10 | 9.5 | 14.0 | 19.5 | 2.0 |
| 1508MFB10 | 15 x 08 | M4 x 10 | 31.0 | 45.5 | 63.0 | 2.0 |
| 1513MFB10 | 15 x 13 | M4 x 10 | 14.5 | 22.5 | 31.0 | 3.3 |
| 1618MFB10 | 16 x 18 | M4 x 10 | 16.0 | 23.5 | 33.0 | 5.0 |
| 2008MFB18 | 20 x 08 | M6 x 18 | 46.5 | 68.0 | 94.0 | 2.0 |
| 2012MFB18 | 20 x 12 | M6 x 18 | 40.0 | 59.5 | 82.0 | 3.0 |
| 2015MFB18 | 20 x 15 | M6 x 18 | 34.0 | 51.5 | 71.0 | 3.75 |
| 2020MFB18 | 20 x 20 | M6 x 18 | 26.0 | 39.0 | 53.5 | 5.0 |
| 2025MFB18 | 20 x 25 | M6 x 18 | 27.0 | 41.0 | 56.5 | 6.25 |
| 2030MFB18 | 20 x 30 | M6 x 18 | 21.5 | 31.0 | 43.5 | 7.5 |
| 2508MFB18 | 25 x 08 | M6 x 18 | 114.0 | 190.0 | 231.0 | 2.0 |
| 2510MFB20 | 25 x 10 | M8 x 20 | 106.5 | 155.0 | 213.5 | 2.5 |
| 2515MFB18 | 25 x 15 | M6 x 18 | 68.0 | 104.0 | 145.5 | 3.75 |
| 2518MFB18 | 25 x 18 | M6 x 18 | 69.5 | 102.0 | 141.0 | 4.25 |
| 2520MFB18 | 25 x 20 | M6 x 18 | 63.0 | 93.0 | 126.0 | 5.0 |
| 2520MFB20 | 25 x 20 | M8 x 20 | 63.0 | 93.0 | 126.0 | 5.0 |
| 2525MFB18 | 25 x 25 | M6 x 18 | 44.5 | 66.0 | 92.0 | 6.25 |
| 2530MFB20 | 25 x 30 | M8 x 20 | 39.0 | 58.0 | 77.5 | 7.5 |
| 3012MFB20 | 30 x 12 | M8 x 20 | 97.0 | 139.5 | 201.0 | 3.25 |
| 3015MFB20 | 30 x 15 | M8 x 20 | 88.3 | 132.0 | 184.5 | 3.75 |
| 3017MFB20 | 30 x 17 | M8 x 20 | 82.0 | 121.0 | 167.0 | 4.25 |
| 3020MFB20 | 30 x 20 | M8 x 20 | 75.5 | 113.5 | 155.0 | 5.00 |
| 3022MFB20 | 30 x 22 | M8 x 20 | 69.0 | 102.0 | 140.5 | 5.50 |
| 3025MFB20 | 30 x 25 | M8 x 20 | 63.0 | 97.0 | 131.0 | 6.25 |
| 3030MFB20 | 30 x 30 | M8 x 20 | 52.5 | 77.5 | 106.5 | 7.50 |
| 3040MFB20 | 30 x 40 | M8 x 20 | 53.5 | 78.5 | 108.5 | 10.0 |
| 4020MFB23 | 40 x 20 | M8 x 23 | 155.0 | 233.0 | 333.5 | 5.0 |
| 4020MFB25 | 40 x 20 | M10 x 25 | 155.0 | 233.0 | 333.5 | 5.0 |
| 4025MFB25 | 40 x 25 | M10 x 25 | 136.0 | 204.0 | 281.5 | 6.3 |
| 4028MFB23 | 40 x 28 | M8 x 23 | 124.0 | 184.5 | 252.0 | 6.8 |
| 4030MFB23 | 40 x 30 | M8 x 23 | 116.5 | 174.5 | 242.5 | 7.5 |
| 4030MFB25 | 40 x 30 | M10 x 25 | 116.5 | 174.5 | 242.5 | 7.5 |
| 4035MFB23 | 40 x 35 | M8 x 23 | 103.0 | 153.5 | 213.5 | 8.8 |
| 4040MFB23 | 40 x 40 | M8 x 23 | 97.0 | 145.5 | 199.0 | 10.0 |

| Part No | D x H | d x L | 45° Shore A | 60° Shore A | 70° Shore A | mm |
|-------------|-----------|----------|-------------|-------------|-------------|-------|
| 4040MFB25 | 40 x 40 | M10 x 25 | 97.0 | 145.5 | 199.0 | 10.0 |
| 5015MFB25 | 50 x 15 | M10 x 25 | 283.0 | 422.0 | 581.0 | 3.8 |
| 5018MFB25 | 50 x 18 | M10 x 25 | 360.0 | 480.0 | 690.0 | 4.0 |
| 5020MFB28 | 50 x 20 | M10 x 28 | 343.0 | 511.0 | 705.0 | 5.0 |
| 5021MFB25 | 50 x 21 | M10 x 25 | 344.0 | 514.0 | 708.0 | 5.3 |
| 5025MFB25 | 50 x 25 | M10 x 25 | 300.5 | 446.0 | 616.0 | 6.3 |
| 5030MFB25 | 50 x 30 | M10 x 25 | 247.0 | 364.0 | 504.0 | 7.5 |
| 5040MFB25 | 50 x 40 | M10 x 25 | 170.0 | 252.0 | 349.0 | 10.0 |
| 5045MFB25 | 50 x 45 | M10 x 25 | 150.5 | 223.0 | 310.5 | 11.3 |
| 5050MFB25 | 50 x 50 | M10 x 25 | 136.0 | 203.5 | 281.5 | 12.5 |
| 6025MFB25 | 60 x 25 | M10 x 25 | 514.0 | 669.5 | 1057.0 | 6.3 |
| 6030MFB37 | 60 x 30 | M12 x 37 | 436.0 | 640.0 | 883.0 | 7.5 |
| 6040MFB25 | 60 x 40 | M10 x 25 | 378.0 | 562.5 | 766.0 | 10.0 |
| 6040MFB37 | 60 x 40 | M12 x 37 | 378.0 | 562.5 | 766.0 | 10.0 |
| 6050MFB37 | 60 x 50 | M12 x 37 | 300.0 | 446.0 | 616.0 | 12.5 |
| 7035MFB25 | 70 x 35 | M10 x 25 | 548.0 | 873.5 | 1203.0 | 8.8 |
| 7035MFB37 | 70 x 35 | M12 x 37 | 548.0 | 873.5 | 1203.0 | 8.8 |
| 7040MFB25 | 70 x 40 | M10 x 25 | 494.5 | 737.0 | 1019.0 | 10.0 |
| 7040MFB37 | 70 x 40 | M12 x 37 | 494.5 | 737.0 | 1019.0 | 10.0 |
| 7045MFB25 | 70 x 45 | M10 x 25 | 436.5 | 650.0 | 873.0 | 11.25 |
| 7045MFB37 | 70 x 45 | M12 x 37 | 436.5 | 650.0 | 873.0 | 11.25 |
| 7525MFB37 | 75 x 25 | M12 x 37 | 883.0 | 1339.0 | 1843.0 | 6.25 |
| 7530MFB37 | 75 x 30 | M12 x 37 | 879.0 | 1309.0 | 1807.0 | 7.50 |
| 7540MFB37 | 75 x 40 | M12 x 37 | 533.0 | 960.0 | 1310.0 | 10.00 |
| 7550MFB37 | 75 x 50 | M12 x 37 | 495.0 | 737.0 | 1018.5 | 12.50 |
| 7555MFB37 | 75 x 55 | M12 x 37 | 427.0 | 640.0 | 883.0 | 13.76 |
| 8030MFB35 | 80 x 30 | M14 x 35 | 1028.0 | 1552.0 | 2134.0 | 7.50 |
| 8080MFB35 | 80 x 80 | M14 x 35 | 407.0 | 601.5 | 824.5 | 20.50 |
| 10030MFB41 | 100 x 30 | M16 x 41 | 1821.0 | 3648.0 | 4920.0 | 7.50 |
| 10040MFB44 | 100 x 40 | M16 x 44 | 1600.0 | 2376.0 | 3250.0 | 10.00 |
| 10050MFB41 | 100 x 50 | M16 x 41 | 1358.0 | 2022.0 | 2794.0 | 12.50 |
| 10055MFB44 | 100 x 55 | M16 x 44 | 1251.0 | 1891.0 | 2570.0 | 13.75 |
| 10060MFB44 | 100 x 60 | M16 x 44 | 1115.0 | 1649.0 | 2275.0 | 15.00 |
| 100100MFB44 | 100 x 100 | M16 x 44 | 630.0 | 936.0 | 1290.0 | 25.00 |

Max compression load in Kg deflection in mm.

This information is for guidance only. Customers are recommended to contact us for further technical information on products and applications.

We reserve the right to alter specifications or withdraw products without notice.

Female Flat Buffer

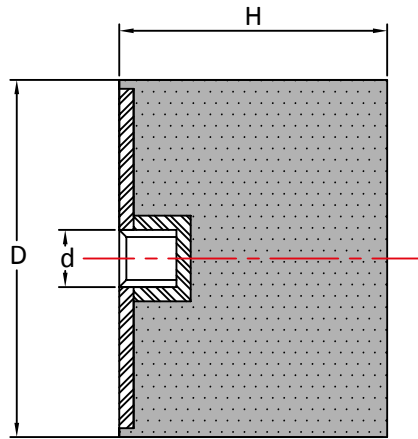

| Part No | D x H | d | 45° Shore A | 60° Shore A | 70° Shore A | mm |
|-----------|---------|-----|-------------|-------------|-------------|-------|
| 1510FFB04 | 15 x 10 | M4 | 26.5 | 35.0 | 47.0 | 2.5 |
| 1515FFB04 | 15 x 15 | M4 | 21.0 | 30.5 | 42.5 | 3.75 |
| 1520FFB04 | 15 x 20 | M4 | 15.5 | 23.0 | 32.0 | 5.0 |
| 2015FFB06 | 20 x 15 | M6 | 34.5 | 52.5 | 72.5 | 3.75 |
| 2020FFB06 | 20 x 20 | M6 | 26.5 | 39.5 | 54.5 | 5.0 |
| 2025FFB06 | 20 x 25 | M6 | 27.5 | 41.5 | 57.5 | 6.25 |
| 2030FFB06 | 20 x 30 | M6 | 22.0 | 31.5 | 44.5 | 7.5 |
| 2515FFB06 | 25 x 15 | M6 | 69.0 | 106.0 | 148.5 | 3.75 |
| 2517FFB06 | 25 x 17 | M6 | 67.5 | 101.0 | 140.0 | 4.25 |
| 2520FFB06 | 25 x 20 | M6 | 64.5 | 95.0 | 128.5 | 5.0 |
| 2525FFB06 | 25 x 25 | M6 | 45.5 | 67.5 | 94.0 | 6.25 |
| 2530FFB06 | 25 x 30 | M6 | 39.5 | 59.5 | 79.0 | 7.50 |
| 3015FFB08 | 30 x 15 | M8 | 90.0 | 134.5 | 188.0 | 3.75 |
| 3017FFB08 | 30 x 17 | M8 | 83.0 | 129.5 | 175.0 | 4.25 |
| 3020FFB06 | 30 x 20 | M6 | 77.0 | 116.0 | 158.5 | 5.0 |
| 3025FFB08 | 30 x 25 | M8 | 55.5 | 84.0 | 119.0 | 6.25 |
| 3030FFB08 | 30 x 30 | M8 | 53.5 | 79.0 | 109.0 | 7.5 |
| 3040FFB08 | 30 x 40 | M8 | 54.5 | 80.0 | 111.0 | 10.0 |
| 4020FFB08 | 40 x 20 | M8 | 158.0 | 238.0 | 327.0 | 5.00 |
| 4020FFB10 | 40 x 20 | M10 | 158.0 | 238.0 | 327.0 | 5.00 |
| 4025FFB08 | 40 x 25 | M8 | 139.0 | 208.0 | 287.0 | 6.25 |
| 4027FFB08 | 40 x 27 | M8 | 125.5 | 186.5 | 255.7 | 6.75 |
| 4028FFB10 | 40 x 28 | M10 | 127.0 | 188.0 | 257.0 | 7.00 |
| 4030FFB08 | 40 x 30 | M8 | 119.0 | 178.0 | 248.0 | 7.50 |
| 4030FFB10 | 40 x 30 | M10 | 119.0 | 178.0 | 248.0 | 7.50 |
| 4035FFB08 | 40 x 35 | M8 | 105.0 | 156.0 | 218.0 | 8.75 |
| 4040FFB08 | 40 x 40 | M8 | 99.0 | 148.0 | 203.0 | 10.00 |
| 5021FFB10 | 50 x 21 | M10 | 352.0 | 525.0 | 723.0 | 5.00 |

| Part No | D x H | d | 45° Shore A | 60° Shore A | 70° Shore A | mm |
|-------------|-----------|-----|-------------|-------------|-------------|-------|
| 5025FFB10 | 50 x 25 | M10 | 307.0 | 455.0 | 629.0 | 6.25 |
| 5030FFB12 | 50 x 30 | M12 | 252.0 | 371.0 | 515.0 | 7.50 |
| 5040FFB10 | 50 x 40 | M10 | 173.0 | 257.0 | 356.0 | 10.00 |
| 5045FFB10 | 50 x 45 | M10 | 153.0 | 228.0 | 317.0 | 11.25 |
| 5050FFB10 | 50 x 50 | M10 | 139.0 | 208.0 | 287.0 | 12.50 |
| 6025FFB10 | 60 x 25 | M10 | 525.0 | 683.0 | 1079.0 | 6.25 |
| 6040FFB10 | 60 x 40 | M10 | 386.0 | 574.0 | 780.0 | 10.0 |
| 6040FFB12 | 60 x 40 | M12 | 386.0 | 574.0 | 780.0 | 10.0 |
| 6045FFB12 | 60 x 45 | M12 | 347.0 | 515.0 | 713.0 | 11.25 |
| 6050FFB12 | 60 x 50 | M12 | 307.0 | 455.0 | 629.0 | 12.5 |
| 7040FFB10 | 70 x 40 | M10 | 505.0 | 752.0 | 1040.0 | 10.0 |
| 7040FFB12 | 70 x 40 | M12 | 505.0 | 752.0 | 1040.0 | 10.0 |
| 7045FFB10 | 70 x 45 | M10 | 446.0 | 663.0 | 890.0 | 11.25 |
| 7045FFB12 | 70 x 45 | M12 | 446.0 | 663.0 | 890.0 | 11.25 |
| 7050FFB10 | 70 x 50 | M10 | 396.0 | 594.0 | 822.0 | 12.5 |
| 7050FFB12 | 70 x 50 | M12 | 396.0 | 594.0 | 822.0 | 12.5 |
| 7525FFB12 | 75 x 25 | M12 | 900.0 | 1365.0 | 1880.0 | 6.25 |
| 7540FFB12 | 75 x 40 | M12 | 545.0 | 980.0 | 1337.0 | 10.00 |
| 7550FFB12 | 75 x 50 | M12 | 505.0 | 752.0 | 1040.0 | 12.50 |
| 7555FFB12 | 75 x 55 | M12 | 435.0 | 653.0 | 900.0 | 13.75 |
| 8040FFB14 | 80 x 40 | M14 | 743.0 | 1109.0 | 1535.0 | 10.00 |
| 8080FFB14 | 80 x 80 | M14 | 416.0 | 614.0 | 842.0 | 20.00 |
| 10030FFB16 | 100 x 30 | M16 | 1821.0 | 3648.0 | 4920.0 | 7.50 |
| 10040FFB16 | 100 x 40 | M16 | 1633.0 | 2425.0 | 3316.0 | 10.00 |
| 10050FFB16 | 100 x 50 | M16 | 1386.0 | 2064.0 | 2850.0 | 12.50 |
| 10055FFB16 | 100 x 55 | M16 | 1277.0 | 1930.0 | 2624.0 | 13.75 |
| 10060FFB16 | 100 x 60 | M16 | 1139.0 | 1683.0 | 2322.0 | 15.00 |
| 100100FFB16 | 100 x 100 | M16 | 644.0 | 955.0 | 1317.0 | 25.00 |

Max compression load in Kg deflection in mm.

This information is for guidance only. Customers are recommended to contact us for further technical information on products and applications.

We reserve the right to alter specifications or withdraw products without notice.

Tapered Buffers

Tapered Buffers are ideal for absorbing shock. They provide high levels of deformation under impact force, and a progressive stiffness rate to accommodate varying shock forces, thus giving excellent levels of absorption and protection of machinery and fabrications.

Stainless Steel Metals, Synthetic rubber compounds and Female Fixings available on request.

Applications include:

- Primary and Secondary suspension for vehicles, bump stops for general Industrial Machinery, Assister springs, Construction and Agricultural Machinery.



| Part No. | D | H | d | L |
|-------------|-----|----|-----|----|
| 1212MCBT10 | 12 | 12 | M4 | 10 |
| 1406MCBT04 | 14 | 6 | M4 | 4 |
| 2512MCBT18 | 25 | 12 | M6 | 18 |
| 2514MCBT10 | 25 | 14 | M4 | 10 |
| 2517MCBT18 | 25 | 17 | M6 | 18 |
| 3627MCBT20 | 36 | 27 | M8 | 20 |
| 4521MCBT46 | 45 | 21 | M8 | 46 |
| 5018MCBT28 | 50 | 18 | M10 | 28 |
| 5020MCBT28 | 50 | 20 | M10 | 28 |
| 5050MCBT28 | 50 | 50 | M10 | 28 |
| 8027MCBT37 | 80 | 27 | M12 | 37 |
| 12545MCBT45 | 125 | 45 | M16 | 45 |

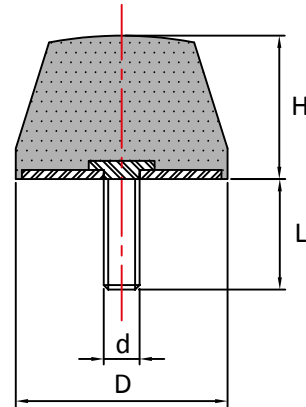

| Part No | D1 | D2 | H | d | L |
|------------|----|----|----|-----|----|
| 3835MFBT27 | 38 | 30 | 35 | M10 | 27 |
| 4335MFBT27 | 43 | 30 | 35 | M10 | 27 |
| 4350MFBT25 | 43 | 30 | 50 | M10 | 25 |

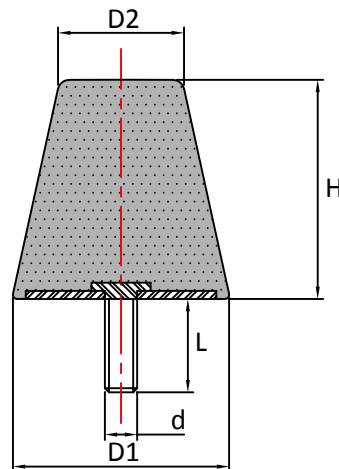

| Part No | D | H | d | L |
|-----------|----|----|-----|----|
| 2417MCB20 | 24 | 17 | M8 | 20 |
| 2516MCB20 | 25 | 16 | M8 | 20 |
| 4024MCB28 | 40 | 24 | M8 | 28 |
| 5028MCB28 | 50 | 28 | M8 | 28 |
| 5045MCB35 | 50 | 45 | M10 | 35 |
| 6045MCB28 | 60 | 45 | M10 | 28 |
| 8565MCB37 | 85 | 65 | M12 | 37 |

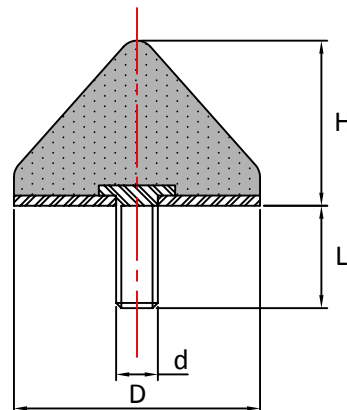

Max compression load in Kg deflection in mm.

This information is for guidance only. Customers are recommended to contact us for further technical information on products and applications. We reserve the right to alter specifications or withdraw products without notice.

Conical Buffers

Conical Buffers are ideal for absorbing shock. They provide high levels of deformation under impact force, and a progressive stiffness rate to accommodate varying shock forces, thus giving excellent levels of absorption and protection of machinery and fabrications.

Stainless Steel Metals, Synthetic rubber compounds and Female Fixings available on request.

Applications include:

- Primary and Secondary suspension for vehicles, bump stops for general Industrial Machinery, Assister springs, Construction and Agricultural Machinery.

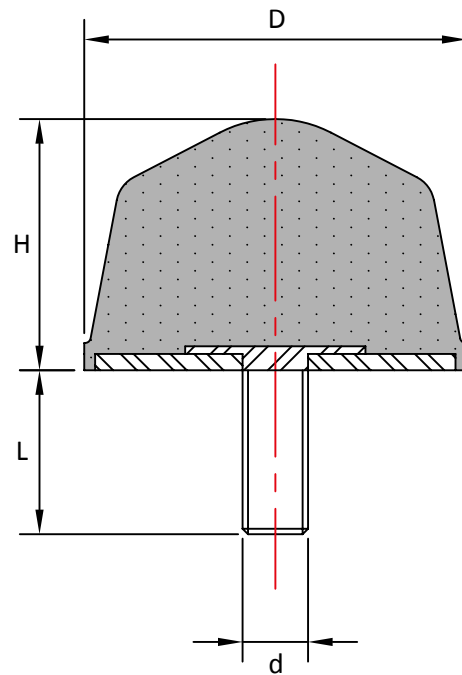
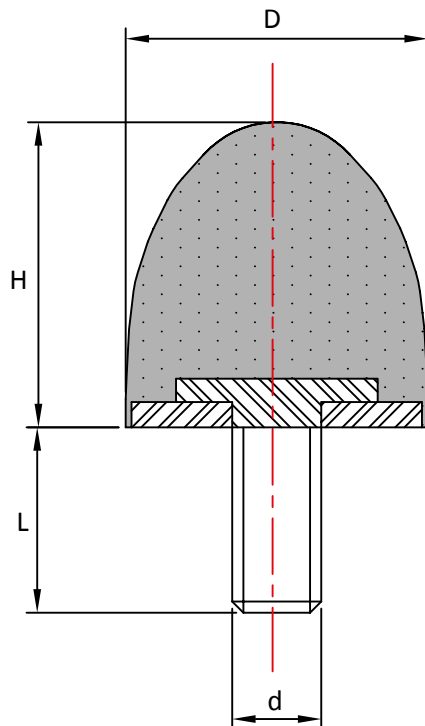

MCB3460

| Part No | D x H | d x L | 45° Shore A | 60° Shore A | 70° Shore A | mm |
|-----------|---------|----------|-------------|-------------|-------------|------|
| 1010MCB12 | 10 x 10 | M5 x 12 | 2.3 | 4.6 | 6.7 | 2.25 |
| 2015MCB10 | 20 x 15 | M6 x 10 | 9.8 | 19.7 | 28.9 | 3.75 |
| 2024MCB18 | 20 x 24 | M6 x 18 | 6.9 | 13.8 | 20.3 | 6.25 |
| 2425MCB18 | 24 x 25 | M6 x 18 | 35 | 51 | 71 | 6.25 |
| 2514MCB20 | 25 x 14 | M8 x 20 | 35 | 50 | 70 | 3.5 |
| 2516MCB18 | 25 x 16 | M6 x 18 | 32 | 64 | 94.08 | 4.0 |
| 3030MCB14 | 30 x 30 | M6 x 14 | 37.0 | 54.0 | 74.0 | 7.5 |
| 3540MCB23 | 35 x 40 | M8 x 23 | 15.3 | 30.6 | 45.0 | 10.0 |
| 4535MCB23 | 45 x 35 | M8 x 23 | 96.0 | 140.0 | 193.0 | 7.5 |
| 5050MCB25 | 50 x 50 | M10 x 25 | 117.0 | 170.0 | 233.0 | 12.5 |
| 5058MCB20 | 50 x 58 | M8 x 20 | 147.0 | 214.0 | 293.0 | 15.0 |
| 5061MCB28 | 50 x 61 | M8 x 28 | 135 | 200 | 260 | 14.5 |
| 5064MCB35 | 50 x 64 | M8 x 35 | 127.0 | 185.0 | 253.0 | 16.0 |

| Part No | D x H | d x L | 45° Shore A | 60° Shore A | 70° Shore A | mm |
|-------------|-----------|----------|-------------|-------------|-------------|------|
| 5067MCB33 | 50 x 67 | M8 x 33 | 120 | 170 | 240 | 16.0 |
| 5068MCB38 | 50 x 68 | M10 x 38 | 120 | 170 | 240 | 16.2 |
| 6040MCB62 | 60 x 40 | M14 x 62 | 209.0 | 305.0 | 418.0 | 10.0 |
| 6060MCB37 | 60 x 60 | M12 x 37 | 195.0 | 286.0 | 395.0 | 15.0 |
| 7058MCB32 | 70 x 58 | M12 x 32 | 164.4 | 328.8 | 483.3 | 13.7 |
| 7060MCB35 | 70 x 60 | M12 x 35 | 210.0 | 360.0 | 419.0 | 14.5 |
| 7589MCB37 | 75 x 89 | M12 x 37 | 95.2 | 190.4 | 279.8 | 21.2 |
| 9580MCB45 | 95 x 80 | M16 x 45 | 407.0 | 594.0 | 814.0 | 20.0 |
| 10095MCB31 | 105 x 95 | M12 x 31 | 225.0 | 450.0 | 680.0 | 24.0 |
| 100100MCB31 | 100 x 100 | M12 x 31 | 220.0 | 440.0 | 660.0 | 23.0 |
| 100120MCB31 | 105 x 121 | M12 x 31 | 210.0 | 420.0 | 630.0 | 30.0 |
| 11877MCB41 | 118 x 77 | M16 x 41 | - | - | - | 18.2 |
| MCB3460* | 70 x 46 | M12 x 30 | 178.0 | 260.0 | 356.0 | 11.5 |

* See illustration for profile of MCB3460

Max compression load in Kg deflection in mm.

This information is for guidance only. Customers are recommended to contact us for further technical information on products and applications. We reserve the right to alter specifications or withdraw products without notice.

Plate Buffers

Plate buffers provide a Heavy Duty solution for absorbing high levels of shock and impact forces. The large rubber section allows for high levels of deformation, ensuring that the impact energy is dissipated effectively.



Applications

- Construction Equipment and Vehicles
- Agricultural Vehicles
- Commercial Vehicles
- General Industrial Machinery

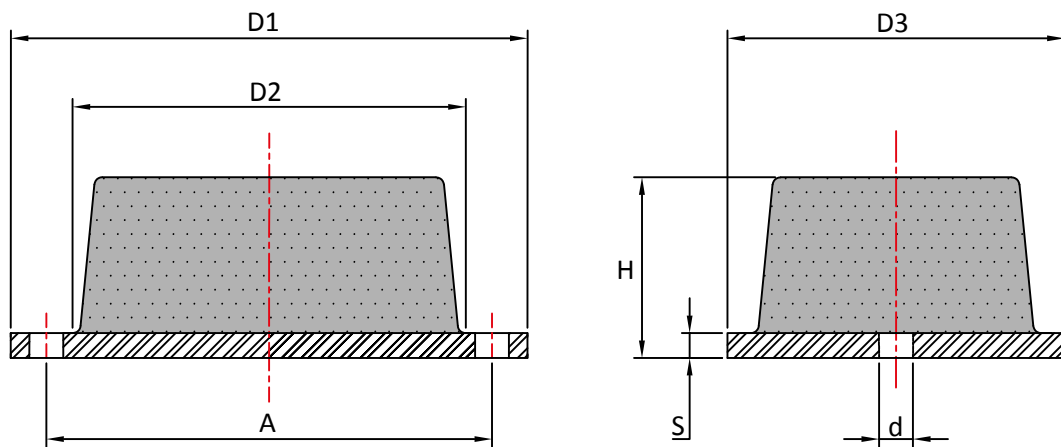

| Part No | D1 | D2 | D3 | A | H | d | S | Max Kg |
|---------|-------|----|------|-------|----|------|-----|--------|
| PB335 | 84.0 | 46 | 32.0 | 68.6 | 19 | 6.9 | 3.2 | 750.0 |
| PB238 | 121.0 | 86 | 57.0 | 105.0 | 56 | 8.6 | 6.3 | 4200.0 |
| PB15 | 150.0 | 90 | 60.0 | 125.0 | 50 | 10.0 | 6.0 | 3000.0 |
| PB260 | 156.0 | 88 | 64.0 | 127.0 | 36 | 13.5 | 5.0 | 2400.0 |

Max compression load in Kg deflection in mm.

This information is for guidance only. Customers are recommended to contact us for further technical information on products and applications. We reserve the right to alter specifications or withdraw products without notice.

Square Plate Buffers

Square Plate buffers provide a Heavy Duty solution for absorbing high levels of shock and impact forces. The large rubber section allows for high levels of deformation, ensuring that the impact energy is dissipated effectively.



Applications

- Construction Equipment and Vehicles
- Mining and Quarry Equipment
- Agricultural Vehicles
- Lifts and Elevators
- General Industrial Machinery

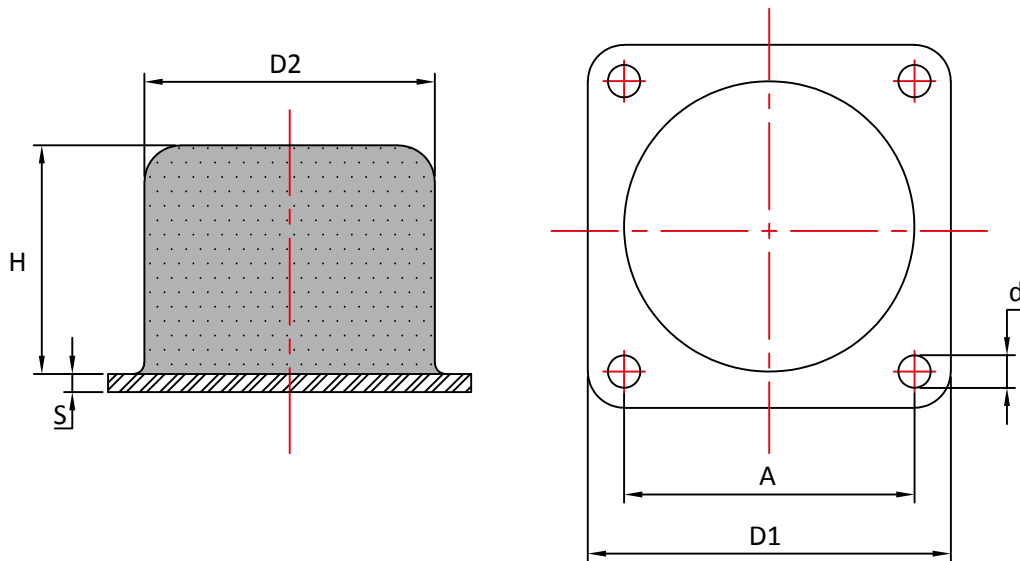

| Part No | D1 | A | D2 | d | H | S | Max Kg |
|----------|-----|-----|-----|-----|-----|---|--------|
| PB50 | 50 | 40 | 40 | 5,5 | 32 | 2 | 1530 |
| PB63 | 63 | 50 | 50 | 6,5 | 40 | 3 | 2440 |
| PB75 | 100 | 75 | 75 | 9 | 60 | 3 | 6000 |
| PB80 | 80 | 63 | 63 | 6,5 | 50 | 4 | 3820 |
| PB100 | 100 | 80 | 80 | 9 | 63 | 5 | 6110 |
| PB125 | 125 | 100 | 100 | 9 | 80 | 6 | 9680 |
| PB130 | 130 | 100 | 100 | 11 | 78 | 6 | 9500 |
| PB1700-2 | 160 | 135 | 125 | 13 | 70 | 6 | 20000 |
| PB160 | 160 | 125 | 125 | 11 | 100 | 6 | 15290 |
| PB200 | 200 | 160 | 160 | 11 | 125 | 8 | 24460 |
| PB250 | 250 | 200 | 200 | 13 | 160 | 8 | 38220 |

Max compression load in Kg deflection in mm.

This information is for guidance only. Customers are recommended to contact us for further technical information on products and applications. We reserve the right to alter specifications or withdraw products without notice.



INDUSTRIAL PRODUCTS

Notes



Flanged Mountings

Captive Transit Mountings

| | |
|----------------------------------|----|
| Captive Transit Mountings | 28 |
| Square Flanged Captive Mountings | 32 |

Silent Marine™ Mountings

| | |
|--------------------------|----|
| Silent Marine™ Mountings | 33 |
| Silent Marine™ Jumbo | 35 |
| Height Adjusters | 36 |

Standard Flanged Mountings

| | |
|--|----|
| Flanged Circular Mountings | 37 |
| Flanged Circular Mountings (FCM763812) | 38 |
| SL Mountings | 39 |
| Turret Mountings | 40 |
| Flanged Mountings | 41 |
| Capped Flanged Mountings | 42 |
| HD Flanged Mountings | 43 |



Captive Transit Mounts



A universal mounting, popular in a wide range of applications. Cost Effective, High Performing and Easy to Install. The rubber is used in shear compression providing optimum performance and offers vibration reduction of up to 95% in all axis. The metal top cap provides protection from contamination such as Oil and Fuel. Load Ratings from 20kg to 5,000kg.

Captive Transit Mounts are designed with an integral overload stop to control movement of the mounted equipment, during transit, and also provide a failsafe arrangement to control shock loads. Suitable for both Mobile and Static applications.

Advantages:

- Failsafe Design – Ideal for Mobile Equipment
- High Performance Vibration Reduction
- Easy to Install
- Protection from Contamination

Applications:

- Generating Sets
- Diesel Engines
- Marine Engines
- Construction and Plant Equipment
- Pumps and Compressors
- Industrial & Commercial Vehicles



Captive Transit Mounts

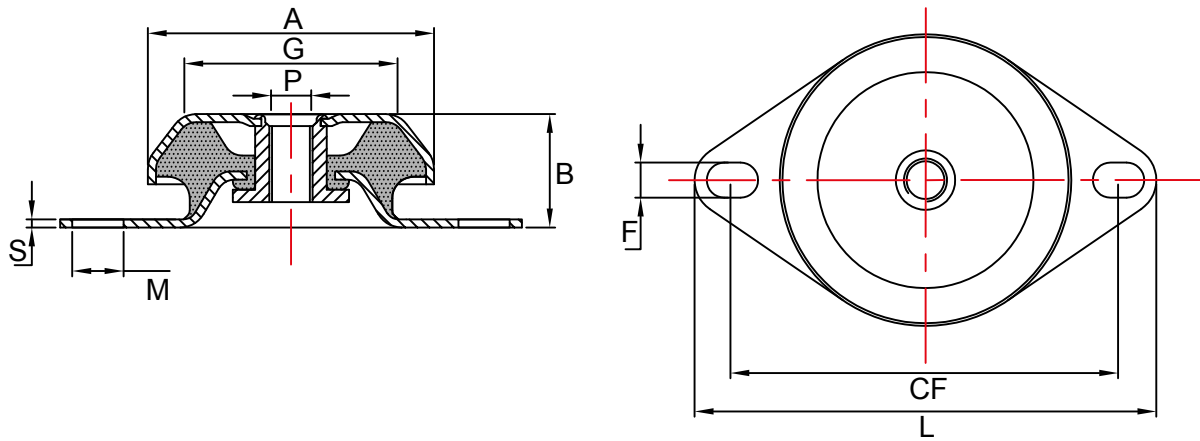

| Part No | A | B | P | F x M | CF | G | L | S |
|----------|-----|----|-----------|-----------|-----------|-----|-----|-----|
| CTM4823 | 48 | 23 | M6/M8 | 6.1ø | 68 | 34 | 84 | 2.0 |
| CTM-R* | 64 | 34 | M12 | 9.5ø | 76 | 47 | 93 | 2.5 |
| CTM6335 | 63 | 35 | M10 / M12 | 9 x 14 | 76 - 90 | 50 | 110 | 2.5 |
| CTM6535 | 65 | 35 | M12 | 15 x 11 | 100 | 45 | 120 | 3.0 |
| CTM7730 | 77 | 30 | M10 / M12 | 9ø | 108 - 110 | 60 | 135 | 3.0 |
| CTM8335 | 83 | 35 | M10 / M12 | 11ø | 108 - 110 | 65 | 135 | 3.0 |
| CTM9245 | 92 | 45 | M12 | 10.5ø | 110 | 73 | 128 | 3.0 |
| CTM9335 | 93 | 35 | M10 / M12 | 10ø | 122 - 124 | 70 | 144 | 2.5 |
| CTM10638 | 106 | 38 | M12 / M16 | 12.5 x 19 | 138-146 | 80 | 171 | 4.0 |
| CTM10642 | 106 | 42 | M12 / M16 | 12.5 x 19 | 138-146 | 80 | 171 | 4.0 |
| CTM10850 | 108 | 50 | M16 | 16.5ø | 160 | 83 | 190 | 5.0 |
| CTM11548 | 115 | 48 | M16 | 16ø | 160 | 85 | 190 | 4.0 |
| CTM12142 | 121 | 42 | M12 / M16 | 13.5ø | 150 - 163 | 92 | 190 | 4.0 |
| CTM12548 | 125 | 48 | M16 | 14 x 11 | 150 - 163 | 99 | 192 | 4.0 |
| CTM14448 | 155 | 48 | M16 | 14 x 11 | 176-188 | 120 | 216 | 4.0 |
| CTM14453 | 155 | 53 | M16 | 14 x 11 | 176-188 | 120 | 216 | 4.0 |

*Manufactured from High Damped Rubber compound



Max compression load in Kg deflection in mm.

This information is for guidance only. Customers are recommended to contact us for further technical information on products and applications. We reserve the right to alter specifications or withdraw products without notice.

CTM4823

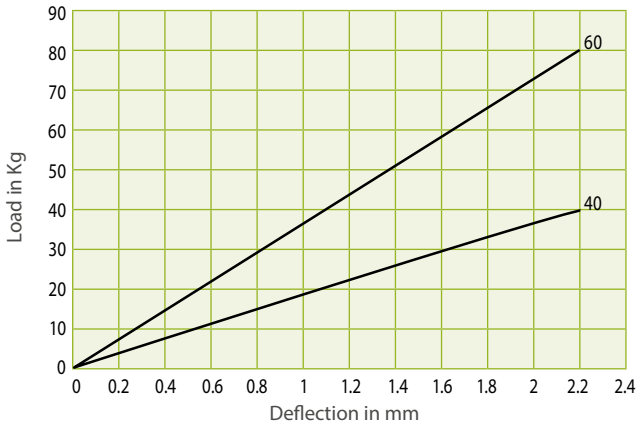

CTM-R

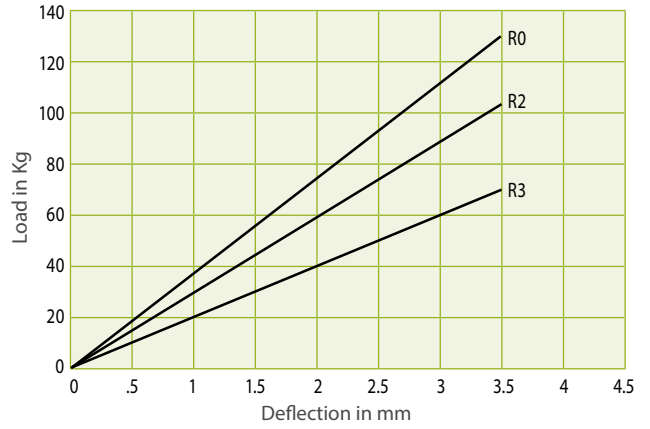

CTM6335

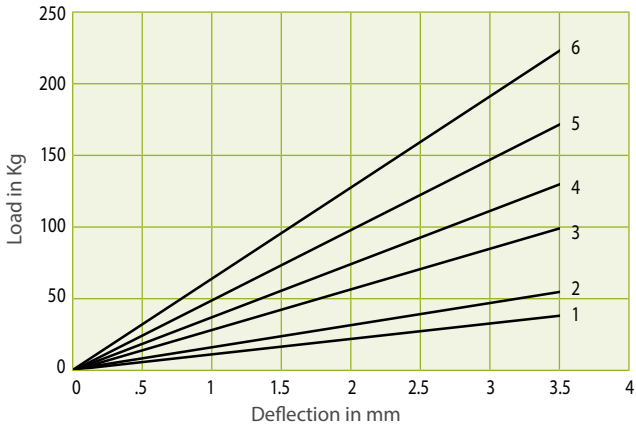

CTM6535

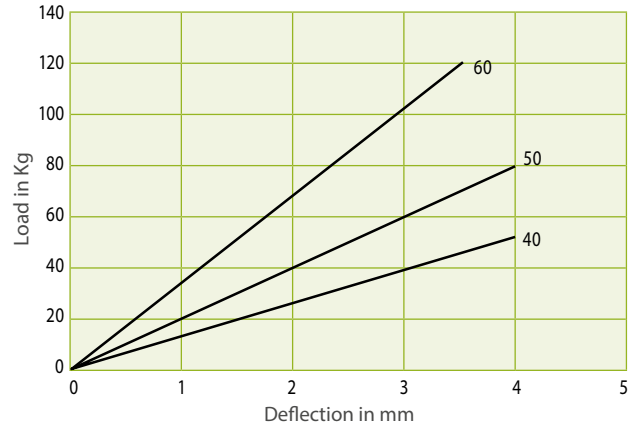

CTM7730

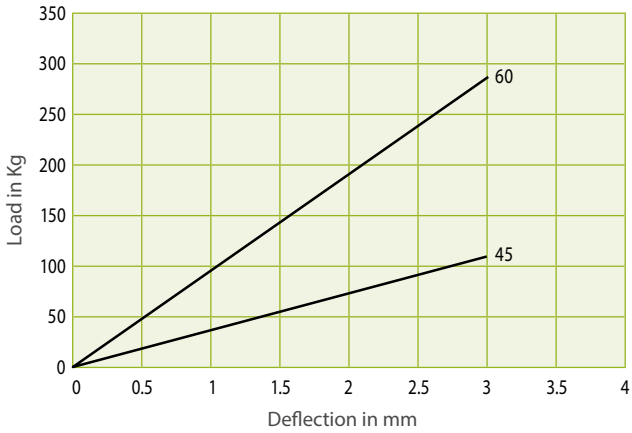

CTM8335

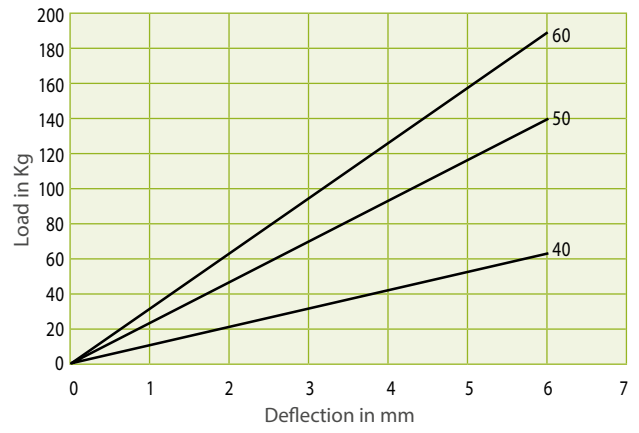

CTM9245

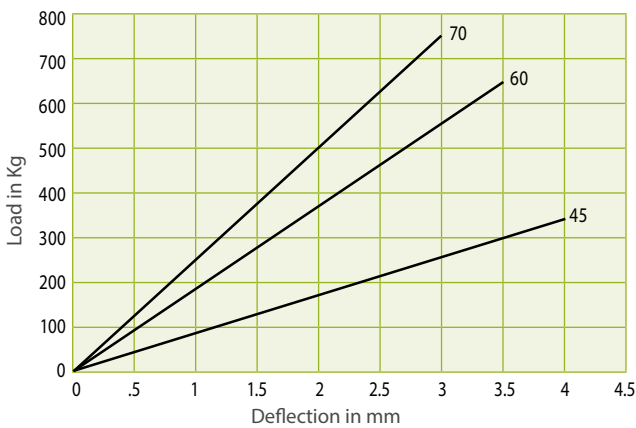

CTM9335

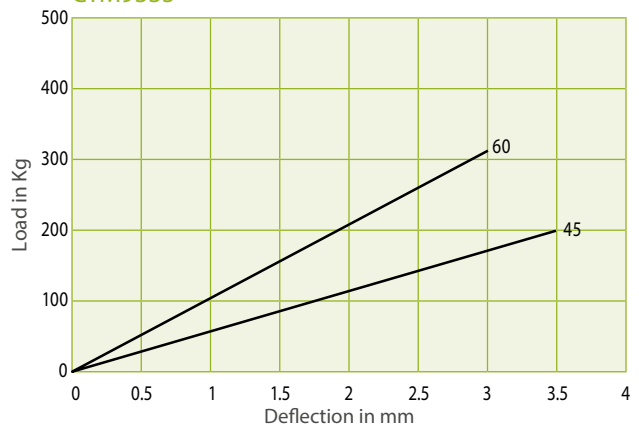

Max compression load in Kg deflection in mm.

This information is for guidance only. Customers are recommended to contact us for further technical information on products and applications.

We reserve the right to alter specifications or withdraw products without notice.

CTM10638

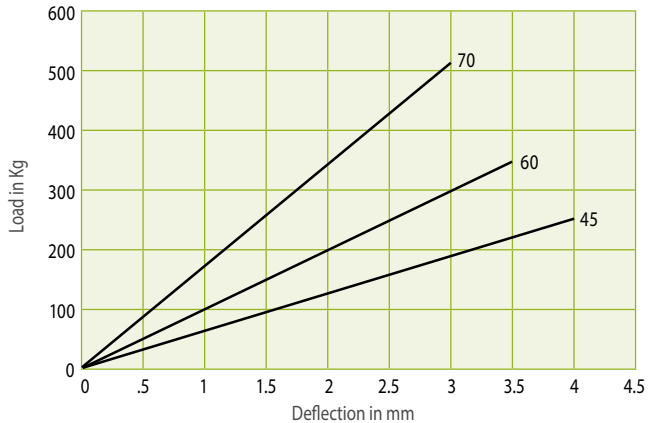

CTM10642

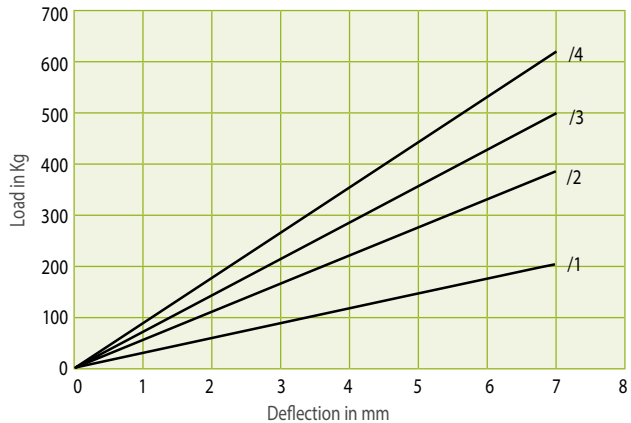

CTM10850

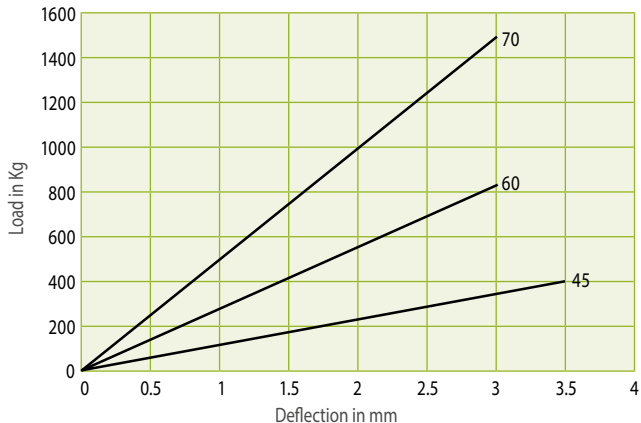

CTM11548

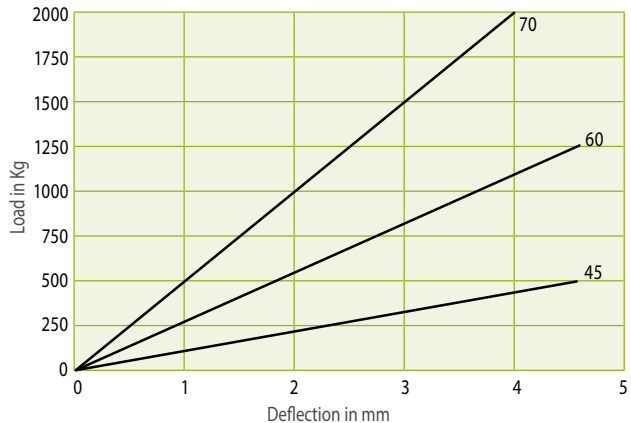

CTM12142

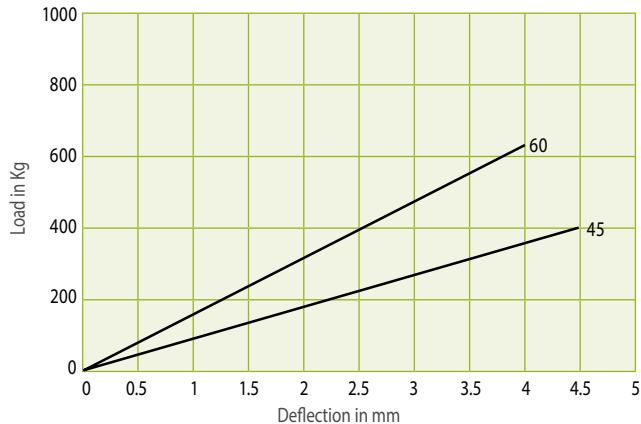

CTM12548

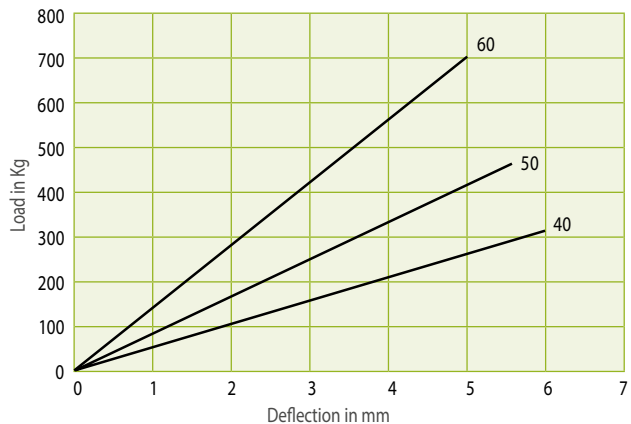

CTM14448



CTM14453

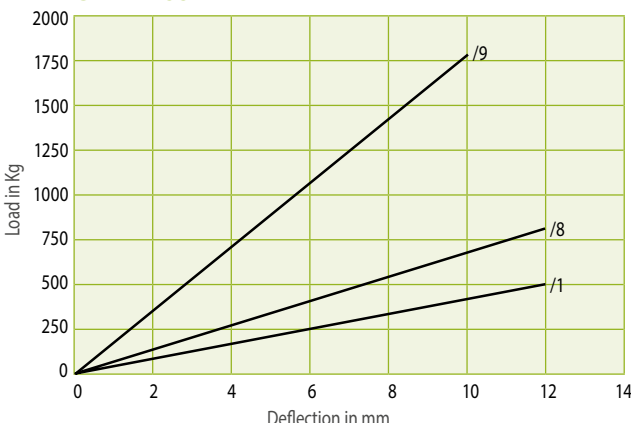

Max compression load in Kg deflection in mm.

This information is for guidance only. Customers are recommended to contact us for further technical information on products and applications.

We reserve the right to alter specifications or withdraw products without notice.

Square Flanged Captive Mounts

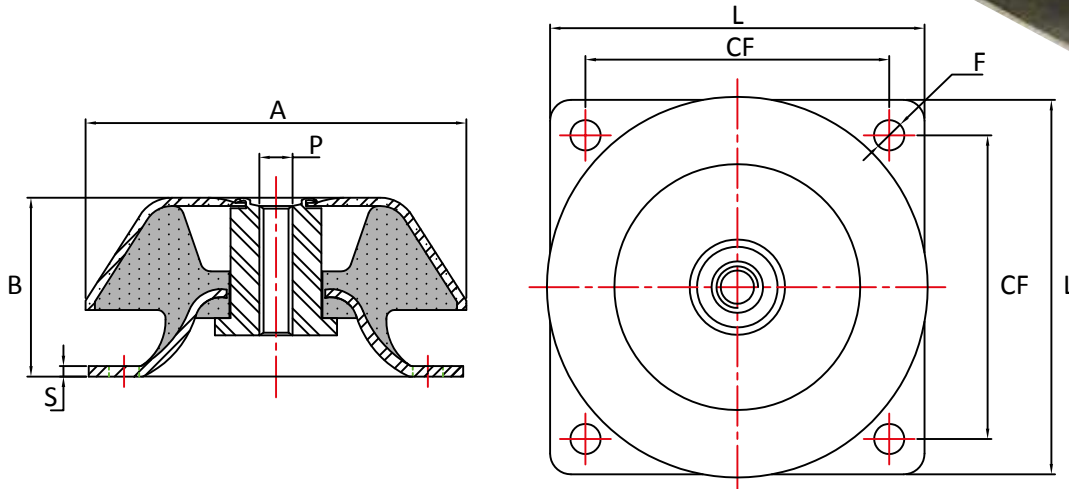

FLANGED MOUNTINGS

| Part No | A | B | P | F | CF | L | S |
|-----------|-----|-----|-----|------|-----------|-----|---|
| SFCM150 | 150 | 50 | M16 | 14.5 | 132 | 170 | 4 |
| SFCM150HD | 150 | 54 | M16 | 14.5 | 132 | 170 | 4 |
| SFCM160 | 162 | 59 | M20 | 14.5 | 140 | 170 | 4 |
| SFCM180 | 180 | 66 | M20 | 14.5 | 149 - 163 | 192 | 5 |
| SFCM180HD | 183 | 86 | M20 | 14.5 | 146 | 180 | 5 |
| SFCM220 | 220 | 105 | M24 | 17.5 | 180 | 220 | 6 |
| SFCM220HD | 220 | 105 | M24 | 17.5 | 180 | 220 | 6 |

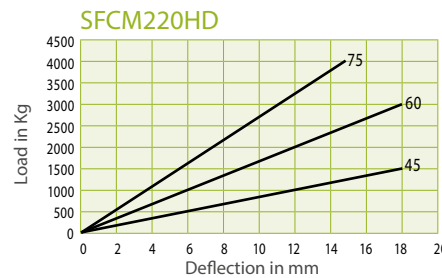
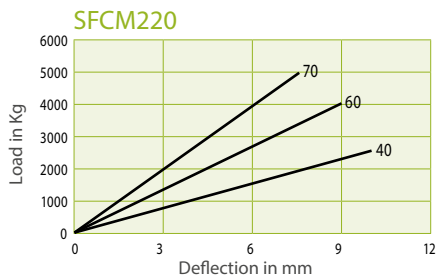
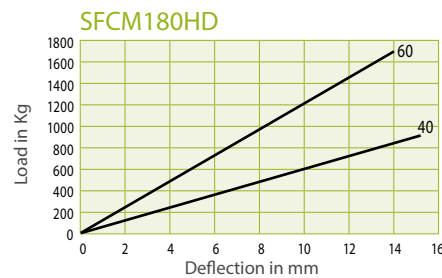
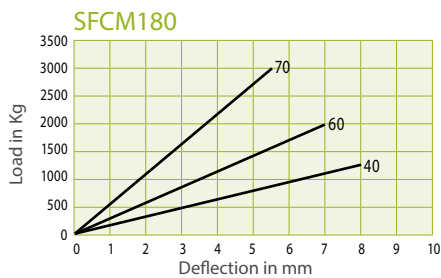
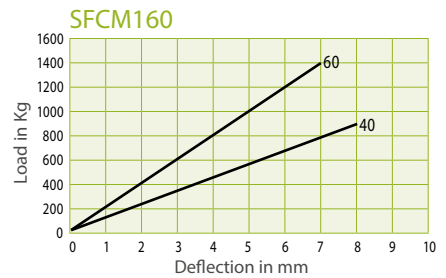
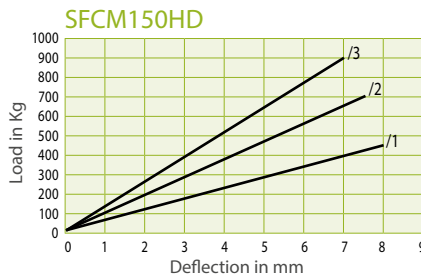
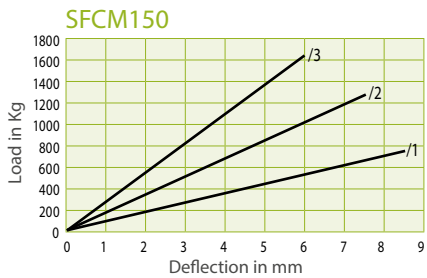

Max compression load in Kg deflection in mm.
 This information is for guidance only. Customers are recommended to contact us for further technical information on products and applications.
 We reserve the right to alter specifications or withdraw products without notice.

Silent Marine™ Mountings

Silent Marine™ Mountings were originally designed for use in Marine Propulsion Engines and therefore are failsafe and can accommodate thrust. Nowadays Silent Marine™ is popular throughout a wide range industries. Offering a High Performance, Easy to Install, and Cost effective solution to reducing vibration. The mountings provide different stiffness' in each axis, which provides optimum performance, particularly for Diesel Engines.

Can also be supplied with Lloyds Approval.

Advantages:

- Ideal for Mobile Applications
- Accommodates Marine Engine Thrust
- Excellent Vibration Absorption
- Easy to Install

Applications:

- Marine Propulsion Engines
- Generating Sets
- Vehicle Diesel Engines
- Pumps
- Compressors



FLANGED MOUNTINGS

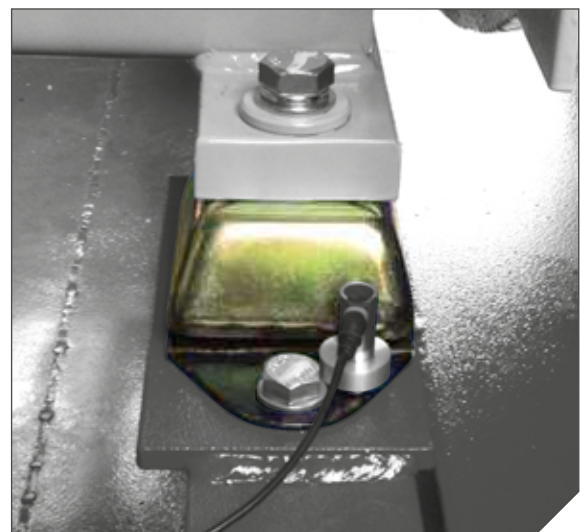

Max compression load in Kg deflection in mm.

This information is for guidance only. Customers are recommended to contact us for further technical information on products and applications. We reserve the right to alter specifications or withdraw products without notice.

Silent Marine™

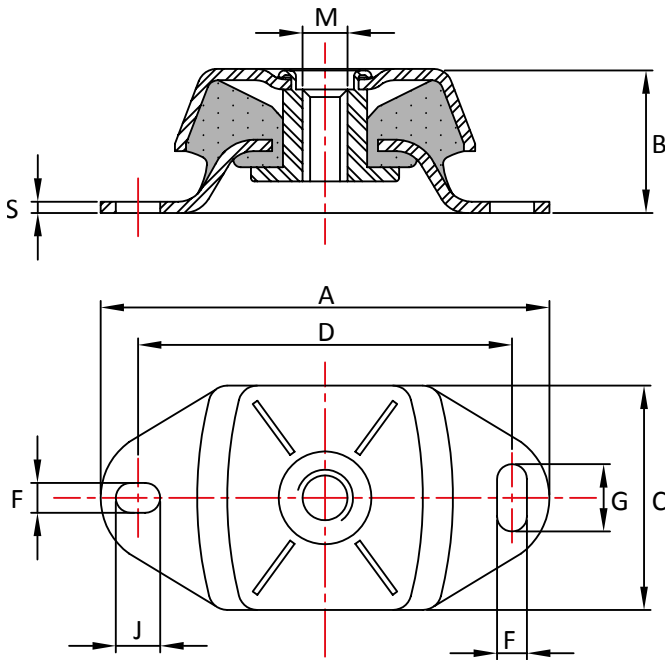

Advantages:

- Ideal for Mobile Applications
- Accommodates Marine Engine Thrust
- Excellent Vibration Absorption
- Easy to Install

Applications:

- Marine Propulsion Engines
- Generating Sets
- Vehicle Diesel Engines
- Pumps
- Compressors

FLANGED MOUNTINGS

| Part No | A | B | C | D | F | M | G | J | S |
|---------|-----|------|-----|-----|----|-----|----|----|---|
| SM1600 | 120 | 38.5 | 60 | 100 | 11 | M12 | 14 | 11 | 3 |
| SM1609 | 183 | 50 | 75 | 140 | 13 | M16 | 30 | 20 | 4 |
| SM1657 | 228 | 70 | 114 | 182 | 18 | M20 | 35 | 25 | 5 |

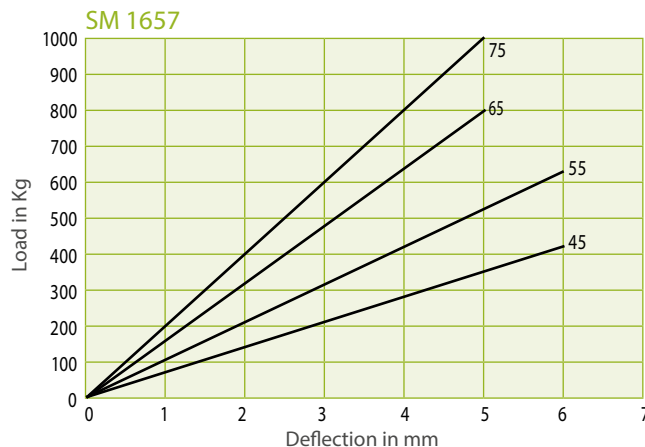
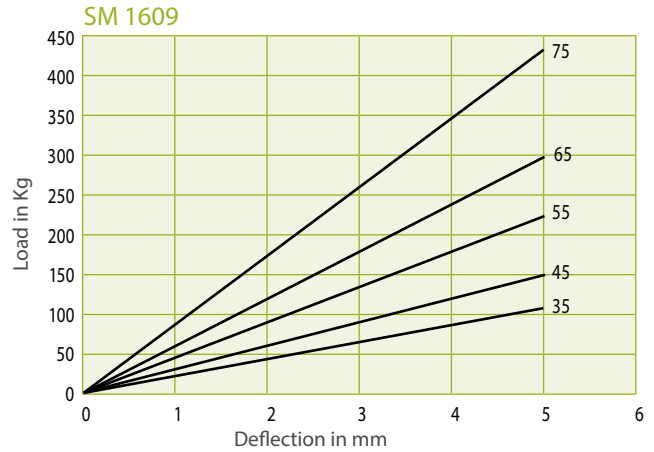
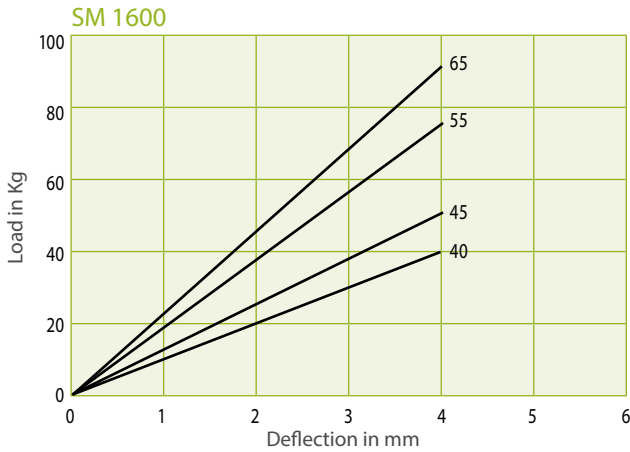

Maximum Loads should be derated for marine propulsion engines.

Height adjusters available see page 36

Max compression load in Kg deflection in mm.

This information is for guidance only. Customers are recommended to contact us for further technical information on products and applications. We reserve the right to alter specifications or withdraw products without notice.

Silent Marine™ Jumbo

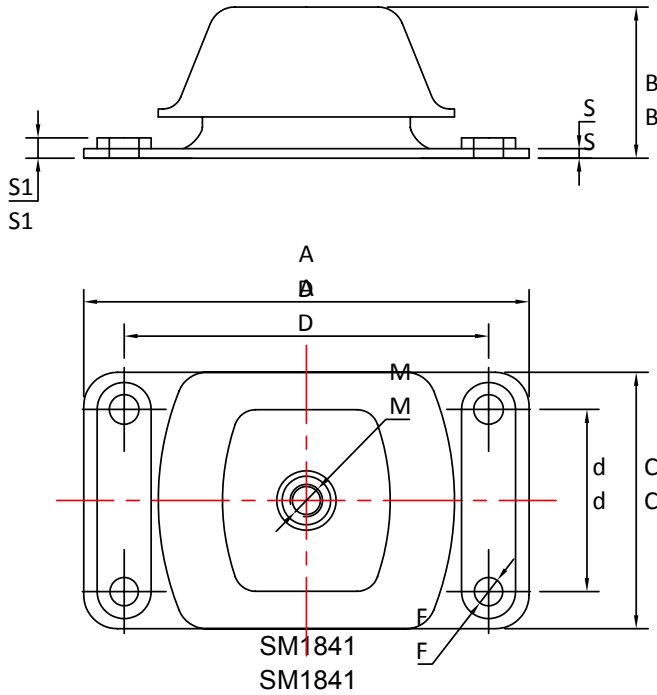

Advantages:

- Ideal for Mobile Applications
- Accommodates Marine Engine Thrust
- Excellent Vibration Absorption
- Easy to Install

Applications:

- Marine Propulsion Engines
- Generating Sets
- Vehicle Diesel Engines
- Pumps
- Compressors

FLANGED MOUNTINGS

| Part No | A | B | C | D | d | F | M | S | S1 |
|---------|-----|-----|-----|-----|-----|----|-----|---|----|
| SM1841 | 330 | 111 | 190 | 270 | 135 | 22 | M24 | 7 | 14 |

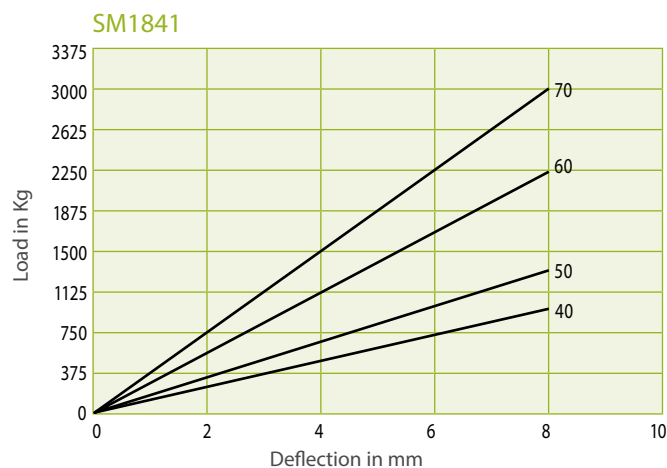

Maximum Loads should be derated for marine propulsion engines.
Height adjusters available see page 36

Max compression load in Kg deflection in mm.
This information is for guidance only. Customers are recommended to contact us for further technical information on products and applications.
We reserve the right to alter specifications or withdraw products without notice.

Height Adjusters



FLANGED MOUNTINGS

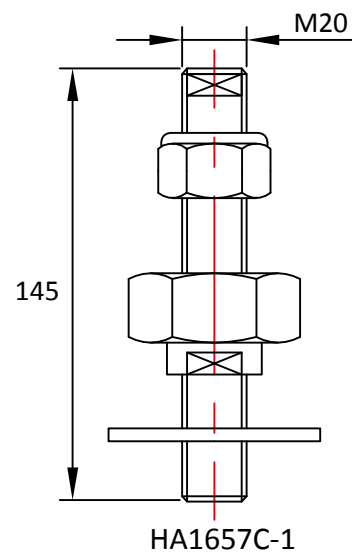
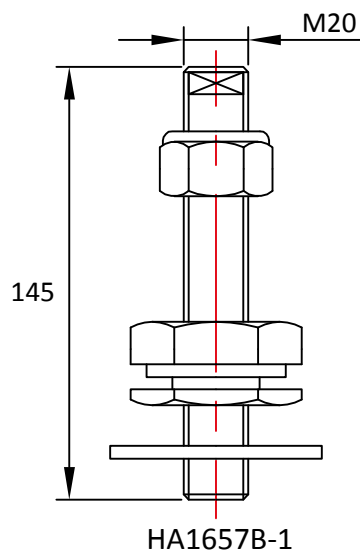
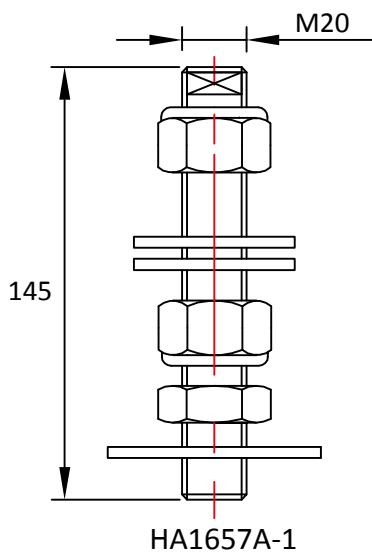
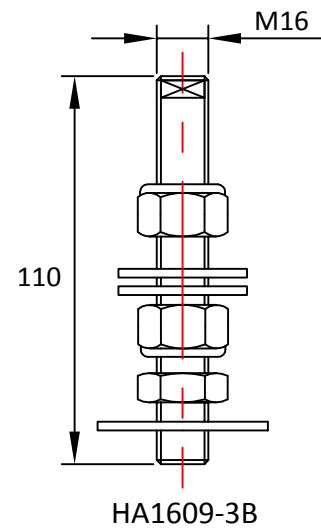
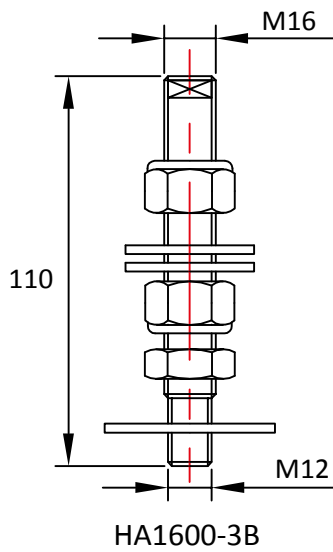
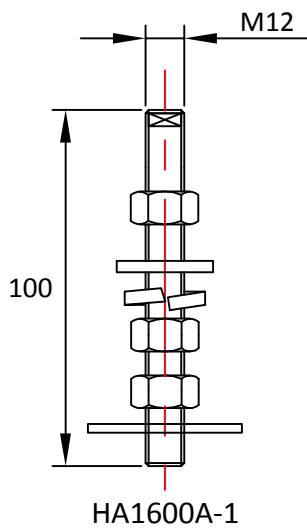

Max compression load in Kg deflection in mm.

This information is for guidance only. Customers are recommended to contact us for further technical information on products and applications. We reserve the right to alter specifications or withdraw products without notice.

Flanged Circular Mountings



Flanged Circular Mountings are a simple, low cost, compression mounting and provide good levels of vibration reduction. The mountings are produced with or without a metal interleaf. The interleaf provides increased load capacity.

Oil and Fuel Resistant rubber compounds and Stainless Steel metals available on request.

Advantages:

- High Load Capacity
- Low Cost
- Easy to Install

Applications:

- Generating Sets
- Pumps
- Compressors
- Processing Equipment

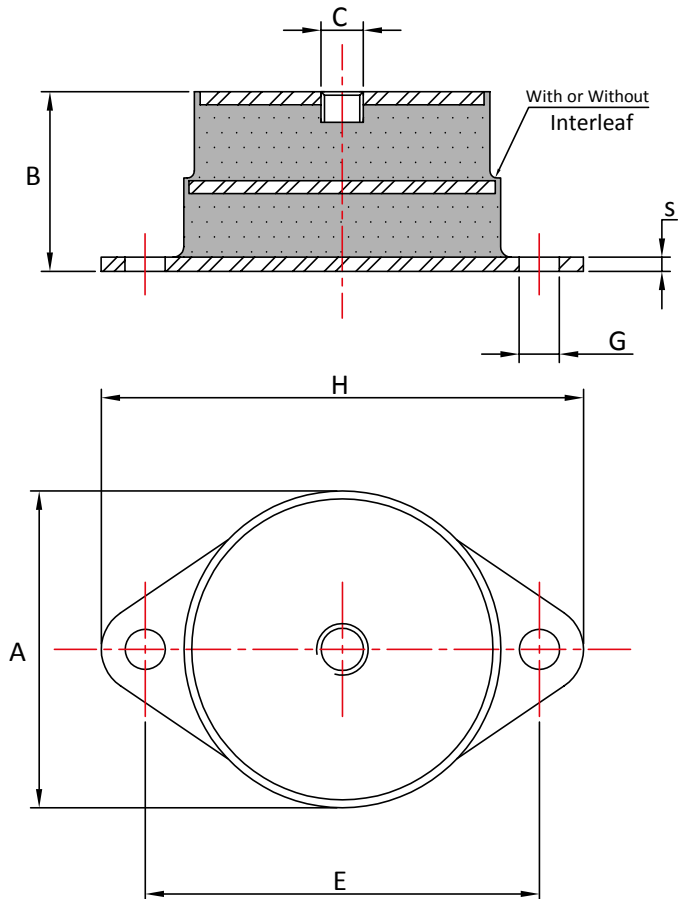

FLANGED MOUNTINGS

| Part No | A | B | C | E | G | H | S | 60° Shore | |
|---------|-----|----|------|---------|---------|-----|---|-----------|-----------|
| | | | | | | | | Load (Kg) | Def. (mm) |
| FCM2 | 76 | 50 | M12* | 100 | 12.5 | 127 | 3 | 250 | 5 |
| FCM2I | 76 | 50 | M12* | 100 | 12.5 | 127 | 3 | 500 | 5 |
| FCM3 | 81 | 50 | M12* | 112 | 12.5 | 140 | 3 | 400 | 5 |
| FCM3I | 81 | 50 | M12* | 112 | 12.5 | 140 | 3 | 750 | 5 |
| FCM5 | 125 | 64 | M20 | 176-184 | 18 x 23 | 220 | 4 | 1200 | 5 |
| FCM5I | 125 | 64 | M20 | 176-184 | 18 x 23 | 220 | 4 | 2000 | 4 |

"I" denotes "Interleaf" * Mountings can be supplied with Stud

Max compression load in Kg deflection in mm.

This information is for guidance only. Customers are recommended to contact us for further technical information on products and applications. We reserve the right to alter specifications or withdraw products without notice.

Flanged Circular Mountings



Flanged Circular Mountings are a simple, low cost, compression mounting and provide good levels of vibration reduction.

Oil and Fuel Resistant rubber compounds and Stainless Steel metals available on request.

Advantages:

- High Load Capacity
- Low Cost
- Easy to Install

Applications:

- Generating Sets
- Pumps
- Compressors
- Processing Equipment

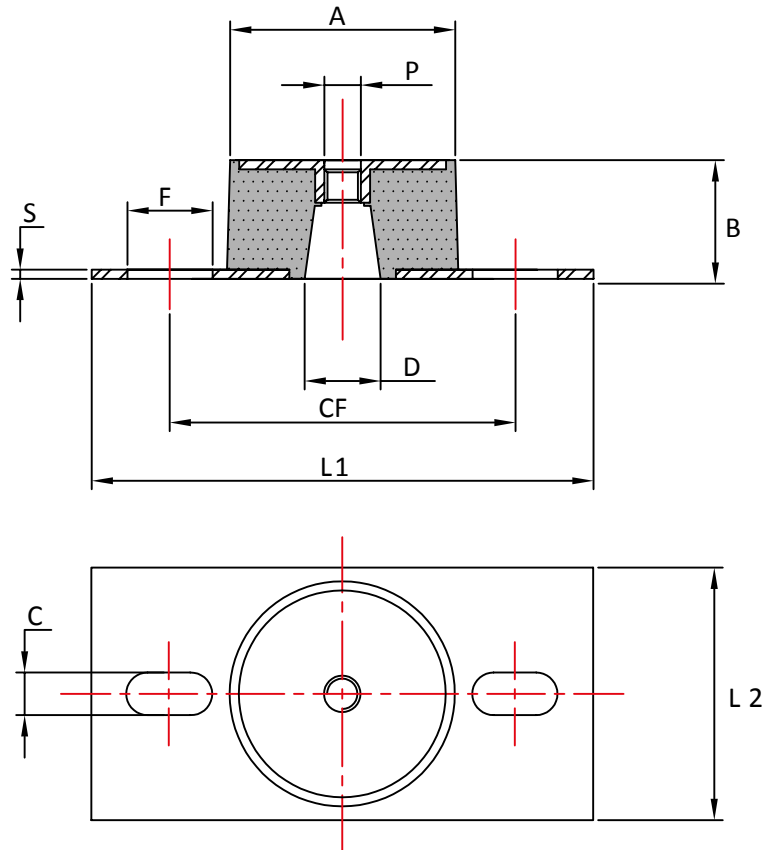

| Part No | A | B | C | D | F | CF | L1 | L2 | P | S |
|-----------|----|----|----|----|----|--------|-----|----|-----|---|
| FCM763812 | 76 | 39 | 14 | 25 | 28 | 99-128 | 165 | 83 | M12 | 3 |

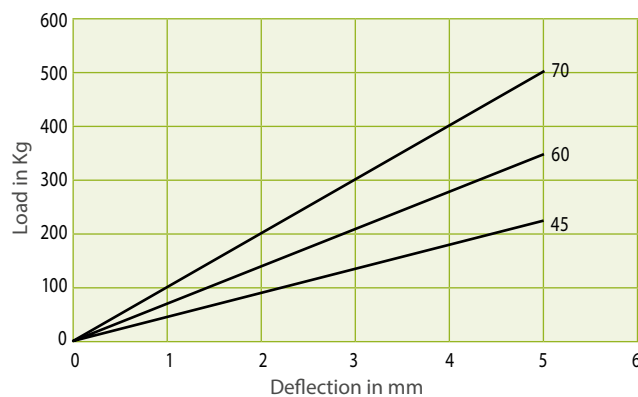

Max compression load in Kg deflection in mm.

This information is for guidance only. Customers are recommended to contact us for further technical information on products and applications. We reserve the right to alter specifications or withdraw products without notice.

SL Mountings

A simple but effective anti-vibration mounting for static machinery. The SL mountings are easy to install and provide effective reduction in structure borne vibration.

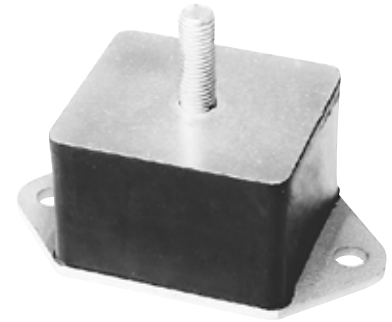

Applications:

- Diesel engines
- Pumps
- Compressors
- Motors
- General industrial machinery

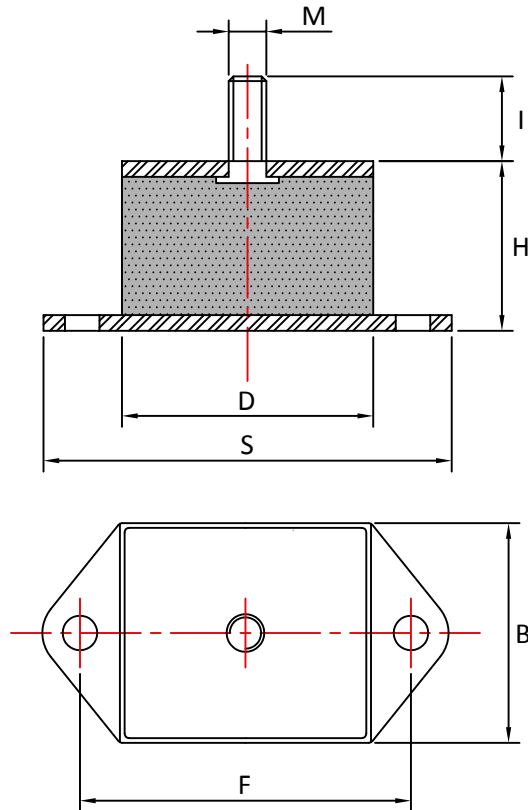

| Part No | F | D | B | H | M | I | S |
|---------|-----|----|----|----|-----|----|-----|
| SL60 | 105 | 80 | 70 | 55 | M12 | 35 | 130 |

Max compression load in Kg deflection in mm.

This information is for guidance only. Customers are recommended to contact us for further technical information on products and applications. We reserve the right to alter specifications or withdraw products without notice.

Turret Mountings



Turret mountings are designed primarily for the HVAC industry, they are a low cost design, ideal for static applications. The rubber completely encapsulates the metal parts to avoid corrosion problems.

They give relatively high levels of deflection, allowing for good levels of vibration reduction to be achieved, even at low running speeds.

Advantages:

- Encapsulated Metals
- High Deflection
- Low Cost
- Easy to Install

Applications:

- HVAC
- Fans
- Pumps
- Compressors

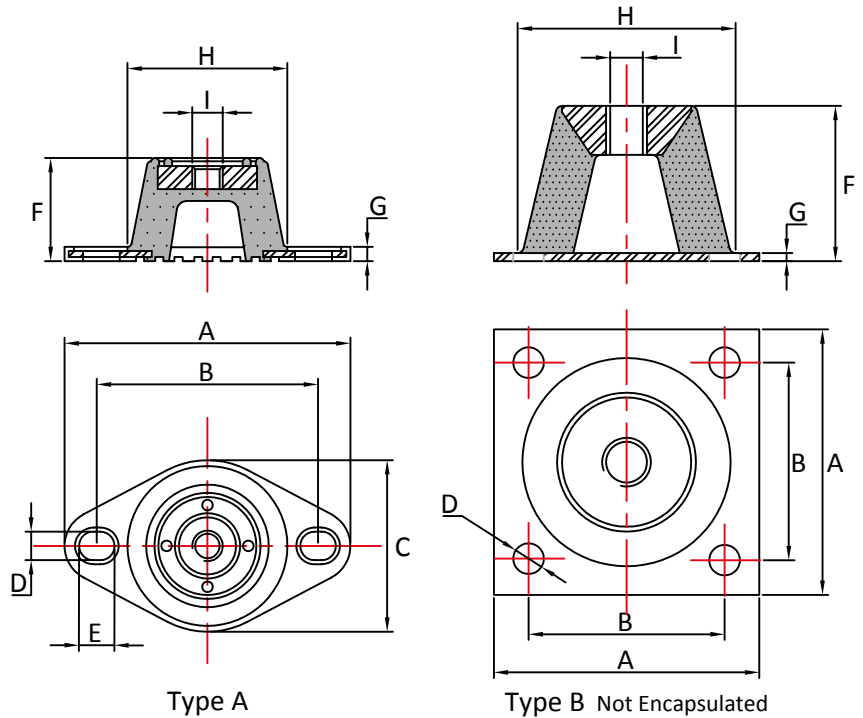

| Part No | Type | A mm | B mm | C mm | D mm | E mm | F mm | G mm | H mm | I mm |
|---------|------|------|---------|------|------|------|------|------|------|------|
| TM229 | A | 62 | 49.2 | 38 | 4.8 | 4.8 | 29.5 | 5.5 | 35.3 | M8 |
| TMS | A | 80 | 54-60 | 45 | 9 | 12 | 32 | 5 | 41 | M8 |
| TMM | A | 95 | 67-76 | 60 | 9 | 14 | 45 | 5 | 56 | M10 |
| TML | A | 150 | 105-126 | 86 | 11 | 22.5 | 70 | 6 | 82 | M12 |
| TMC6535 | B | 65 | 48 | - | 7.5 | - | 36 | 2 | 51 | M10 |

| Part No | Max Load (Kg) | Max Deflection (mm) | Hardness Shore A | Colour Code |
|-------------|---------------|---------------------|------------------|-------------|
| TM229-40 | 5 | 2.7 | 40 | PURPLE |
| TM229-50 | 10 | 2.5 | 50 | GREEN |
| TM229-60 | 15 | 2.0 | 60 | YELLOW |
| TMS08035-45 | 35 | 8.0 | 45 | YELLOW |
| TMS08065-55 | 65 | 8.0 | 55 | BLUE |
| TMS08100-65 | 100 | 8.0 | 65 | RED |
| TMM10130-45 | 130 | 10.0 | 45 | YELLOW |
| TMM10225-55 | 225 | 10.0 | 55 | BLUE |
| TMM10350-65 | 350 | 10.0 | 65 | RED |
| TML10185-45 | 185 | 10.0 | 45 | YELLOW |
| TML10320-55 | 320 | 10.0 | 55 | BLUE |
| TML10500-65 | 500 | 10.0 | 65 | RED |
| TMC6535-45 | 45 | 5.6 | 45 | WHITE |
| TMC6535-55 | 75 | 5.9 | 55 | RED |
| TMC6535-65 | 115 | 5.0 | 65 | BLACK |

Max compression load in Kg deflection in mm.

This information is for guidance only. Customers are recommended to contact us for further technical information on products and applications. We reserve the right to alter specifications or withdraw products without notice.

Flanged Mountings

Flanged Mountings give high levels of deflection, providing excellent levels of vibration reduction and shock absorption both in the vertical and horizontal planes. They are particularly suited to isolating slow speed equipment.

Stainless Steel metals and Oil / Heat resistant rubbers available on request.

Advantages:

- Ideal for Slow Speed Equipment
- Easy to Install
- Low Cost
- Vibration Isolation up to 95%

Applications:

- Pumps
- Fans
- Compressors
- Vibratory Screens
- Shock Packaging

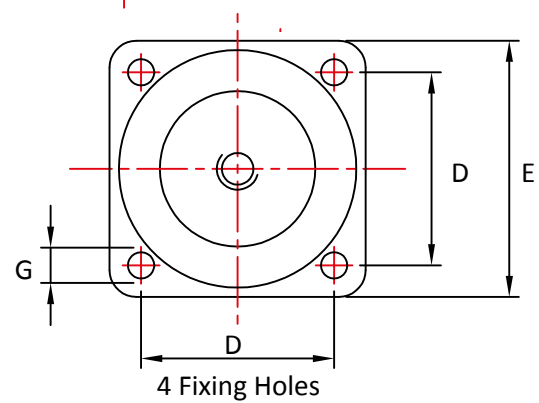
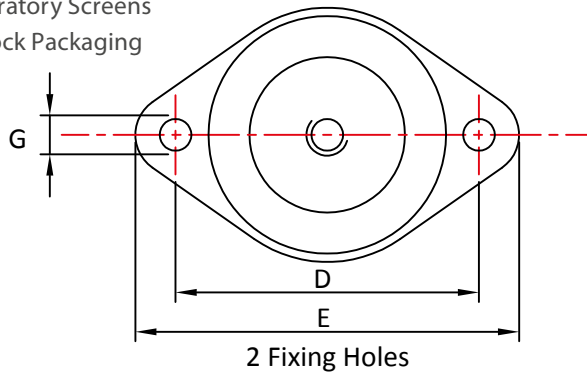
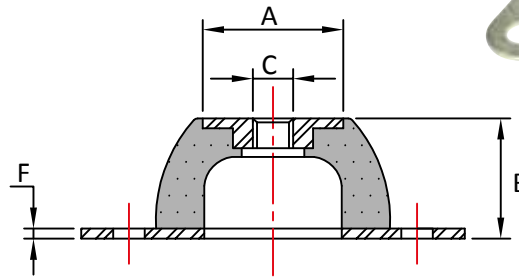

| Part No | Fixing Holes | A (mm) | B (mm) | C | D (mm) | E (mm) | F (mm) | G (mm) |
|---------|--------------|--------|--------|--------|---------|--------|--------|--------|
| FM1566 | 2 | 26.5 | 11.6 | M6 | 50 | 60 | 1.74 | 6 |
| FM209 | 2 | 31 | 21.5 | M8/M10 | 60 | 77 | 3 | 9.2 |
| FM007 | 2 | 18 | 20 | M6 | 50 | 64 | 2 | 7 |
| FM25 | 2 | 33 | 25 | M8/M10 | 66 – 73 | 85 | 2 | 8 x 12 |
| FM50 | 2 | 45 | 35 | M10 | 92 | 114 | 2 | 10 |
| FM100 | 2 | 53 | 40 | M10 | 110 | 136 | 2 | 11.5 |
| FM200 | 2 | 58 | 45 | M10 | 124 | 151 | 3 | 11.5 |
| FM400 | 4 | 70 | 63 | M12 | 120 | 150 | 3 | 14.5 |
| FM600 | 4 | 100 | 85 | M16 | 160 | 200 | 4 | 14.5 |
| FM1500 | 4 | 186 | 160 | M24 | 250 | 310 | 6 | 18 |

| Part No | 40 Shore | | 60 Shore | | 75 Shore | |
|---------|----------|------|----------|------|----------|------|
| | kg | mm | kg | mm | kg | mm |
| FM1566 | 10.0 | 1.4 | 20.0 | 1.35 | 23.0 | 1.1 |
| FM209 | 40.0 | 3.0 | 76.0 | 2.8 | 112.0 | 2.5 |
| FM007 | 3.5 | 3.0 | 9.0 | 3.0 | 13.0 | 2.7 |
| FM25 | 20.0 | 4.5 | 40.0 | 4.5 | 57.0 | 4.0 |
| FM50 | 38.0 | 5.0 | 69.0 | 4.8 | 101.0 | 4.5 |
| FM100 | 60.0 | 7.0 | 100.0 | 6.5 | 147.0 | 6.0 |
| FM200 | 130.0 | 10.0 | 220.0 | 9.0 | 320.0 | 8.5 |
| FM400 | 270.0 | 14.5 | 540.0 | 13.0 | 793.0 | 9.5 |
| FM600 | 375.0 | 17.0 | 750.0 | 15.5 | 1103.0 | 12.0 |
| FM1500 | 1150.0 | 46.0 | 2300.0 | 41.5 | 3381.0 | 37.0 |

Max compression load in Kg deflection in mm.

This information is for guidance only. Customers are recommended to contact us for further technical information on products and applications. We reserve the right to alter specifications or withdraw products without notice.

Capped Flanged Mountings



Flanged Mountings give high levels of deflection, providing excellent levels of vibration reduction and shock absorption both in the vertical and horizontal planes.

They are particularly suited to isolating slow speed equipment.

The mountings are supplied with a metal top cap to ensure the load is evenly spread on the rubber surface and also provides splash protection against fuel and oils.

Advantages:

- Ideal for Lightweight Equipment
- Easy to Install
- Low Cost
- Vibration Isolation up to 95%

Applications:

- Pumps
- Fans
- Compressors

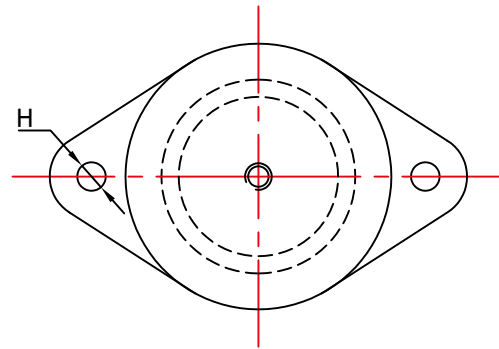
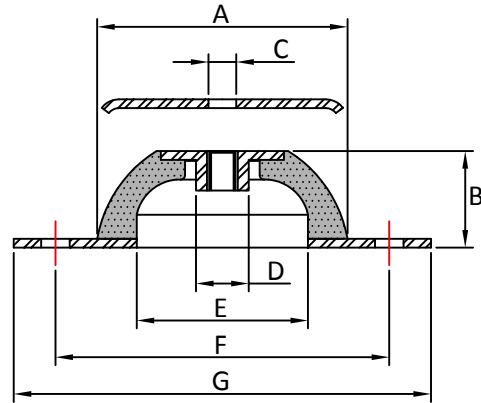

| Part No | A | B | C | D | E | F | G | H |
|---------|-----|----|-----|----|-----|-----|-----|------|
| FM4020 | 40 | 20 | M6 | 19 | 29 | 52 | 64 | 6.2 |
| FM6024 | 60 | 24 | M6 | 14 | 34 | 76 | 90 | 6.2 |
| FM8027 | 80 | 27 | M8 | 25 | 65 | 100 | 120 | 8.2 |
| FM10028 | 100 | 28 | M10 | 22 | 70 | 124 | 148 | 10.0 |
| FM15039 | 150 | 39 | M14 | 34 | 115 | 182 | 214 | 12.0 |
| FM20044 | 200 | 44 | M18 | 35 | 140 | 240 | 280 | 15 |

| Part No | 45 Shore | | 60 Shore | | 75 Shore | |
|---------|----------|----|----------|-----|----------|-----|
| | kg | mm | kg | mm | kg | mm |
| FM4020 | 4 | 2 | 10 | 2.5 | 17 | 2.5 |
| FM6024 | 15 | 3 | 25 | 3 | 45 | 3 |
| FM8027 | 75 | 7 | 110 | 6 | 150 | 4 |
| FM10028 | 90 | 4 | 160 | 4 | 220 | 4 |
| FM15039 | 130 | 7 | 250 | 7 | 350 | 6 |
| FM20044 | 500 | 7 | 825 | 7 | 1250 | 6 |

Max compression load in Kg deflection in mm.

This information is for guidance only. Customers are recommended to contact us for further technical information on products and applications. We reserve the right to alter specifications or withdraw products without notice.

High Deflection Flanged Mountings



HD Flanged Mountings offer high levels of deflection, providing excellent levels of vibration reduction and shock absorption both in the vertical and horizontal planes. The metals are encapsulated in rubber to provide excellent corrosion resistance.

Advantages:

- High Deflection
- Easy to Install
- Encapsulated Metals
- Common Height throughout product range

Applications:

- Pumps
- HVAC (Fans)
- Compressors
- Shock protection

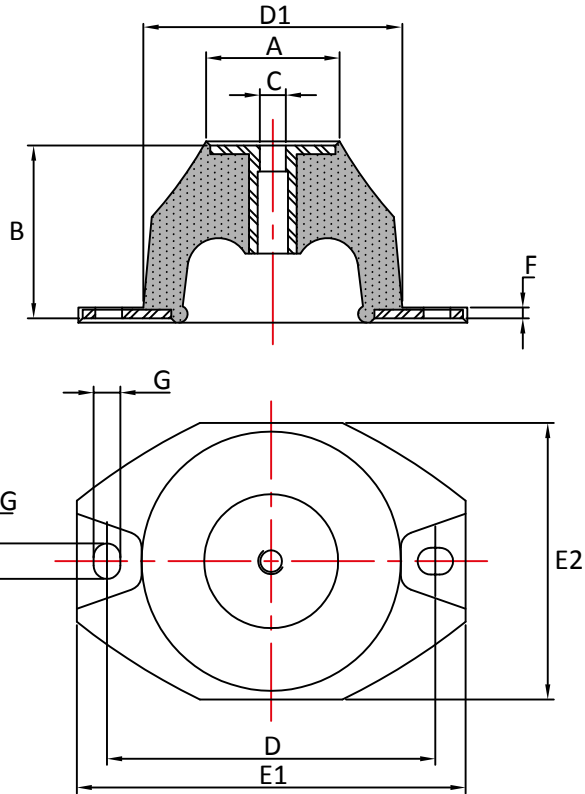

| Part No | A | B | C | D | D1 | E1 | E2 | F | G |
|-----------|-----|----|-----|-----|-----|-----|-----|-----|-------------|
| FM4012 | 12 | 40 | M6 | 52 | 40 | 64 | 44 | 2.5 | 6.2 x 6.2 |
| FM6050 | 32 | 40 | M6 | 76 | 60 | 90 | 64 | 2.5 | 8.2 x 6.2 |
| FM80130 | 48 | 40 | M8 | 100 | 80 | 122 | 84 | 2.5 | 12.2 x 8.2 |
| FM100260 | 68 | 40 | M10 | 124 | 100 | 152 | 104 | 3 | 16.2 x 10.2 |
| FM150500 | 116 | 40 | M12 | 182 | 150 | 214 | 154 | 4.5 | 20.2 x 12.2 |
| FM2001350 | 159 | 40 | M16 | 240 | 200 | 280 | 204 | 5.5 | 24.2 x 14.2 |

| Part No | Hardness /1 | | Hardness /2 | | Hardness /3 | | Hardness /4 | |
|-----------|-------------|----|-------------|----|-------------|----|-------------|----|
| | kg | mm | kg | mm | kg | mm | kg | mm |
| FM4012 | 4 | 8 | 7 | 8 | 12 | 8 | 15 | 8 |
| FM6050 | 20 | 8 | 30 | 8 | 50 | 8 | 62.5 | 8 |
| FM80130 | 70 | 8 | 100 | 8 | 130 | 8 | 162.5 | 8 |
| FM100260 | 160 | 8 | 200 | 8 | 260 | 8 | 325 | 8 |
| FM150500 | 325 | 8 | 400 | 8 | 500 | 8 | 625 | 8 |
| FM2001350 | 640 | 8 | 820 | 8 | 1050 | 8 | 1350 | 8 |

Max compression load in Kg deflection in mm.

This information is for guidance only. Customers are recommended to contact us for further technical information on products and applications. We reserve the right to alter specifications or withdraw products without notice.



INDUSTRIAL PRODUCTS

Notes

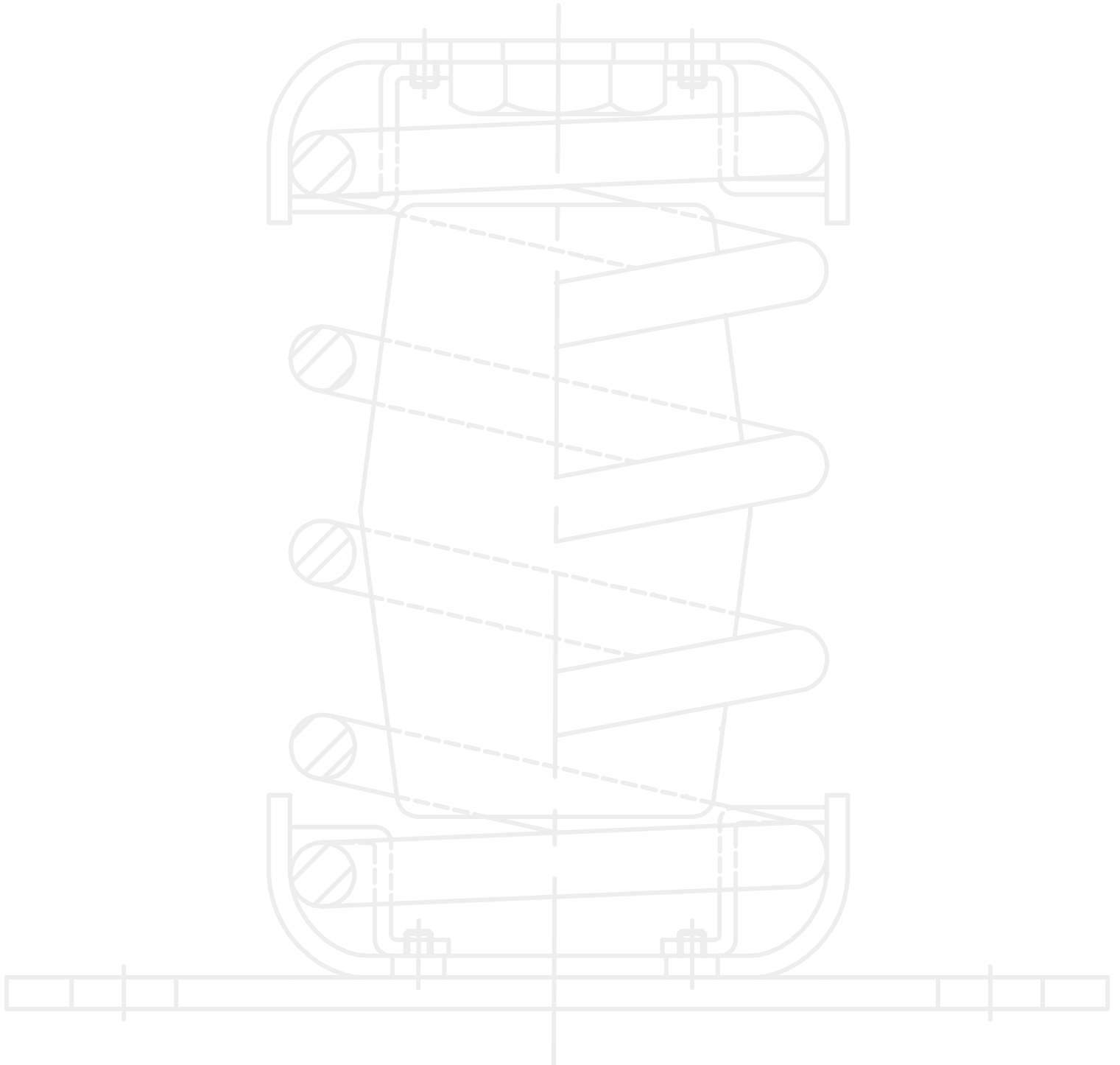



INDUSTRIAL PRODUCTS

Machinery Mountings

| | | | |
|---------------------------------------|----|----------------------------------|----|
| Cast Foot Mountings | 46 | Spring Mountings | 53 |
| Rectangular Sandwich Mountings | 47 | Enclosed Spring Mountings | 54 |
| Rail Mountings | 48 | Enclosed Spring Mountings | 55 |
| Levelling Feet | 49 | Installation Instructions | 56 |
| Adjustable Levelling Feet | 50 | Open Spring Mountings | 57 |
| Anti-Vibration Rubber Feet | 51 | Hangers | 58 |
| KG Block | 52 | Wire Rope Shock Mountings | 59 |

MACHINERY MOUNTINGS



Cast Foot Mountings



Cast Foot Mountings are the ideal choice for large reciprocating machinery and heavy duty industrial equipment. Using the rubber in Shear/Compression they can accommodate high loads and provide excellent vibration reduction properties of up to 98%. The strong construction of the mounting ensures a safe, reliable product with extended service life and very high performance. These mountings can also be supplied with fail-safe stops for mobile applications.

Advantages:

- Robust Design
- Load Range from 30kg to 1800kg per Mounting
- Superior Vibration Reduction
- Easy to Install

Applications:

- Diesel Engines
- Generator Sets
- Compressors
- Fans
- Pumps
- Industrial Machinery

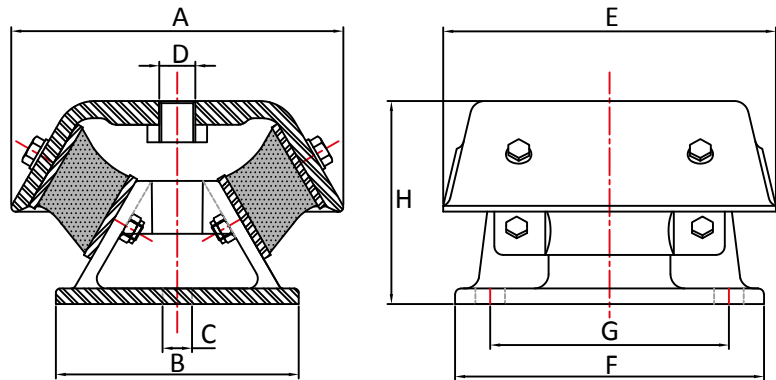

| Part No | A | B | C | D | E | F | G | H |
|---------|-----|-----|----|-----|-----|-----|-----|------|
| CFM290 | 132 | 82 | 13 | M16 | 122 | 114 | 90 | 71.5 |
| CFM213 | 204 | 146 | 18 | M16 | 230 | 205 | 165 | 110 |
| CFM346 | 204 | 146 | 18 | M16 | 230 | 205 | 165 | 120 |

For free standing installations rubber base pads can be supplied.

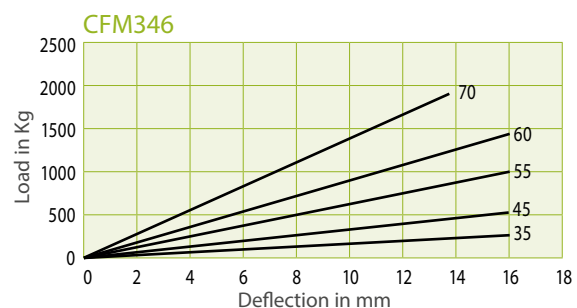
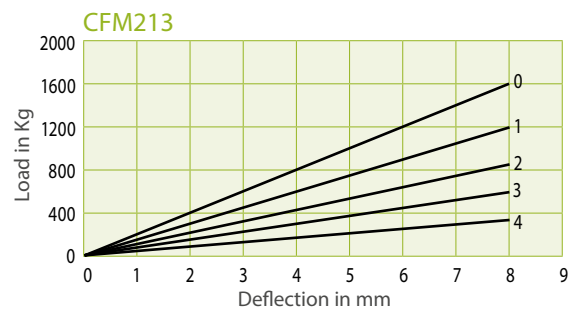
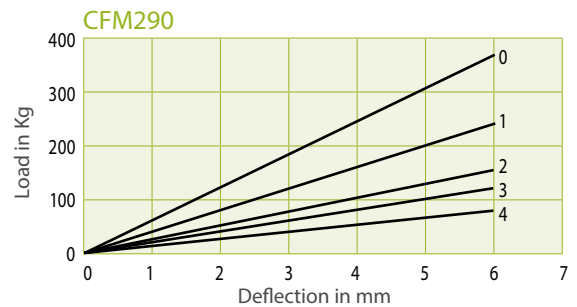
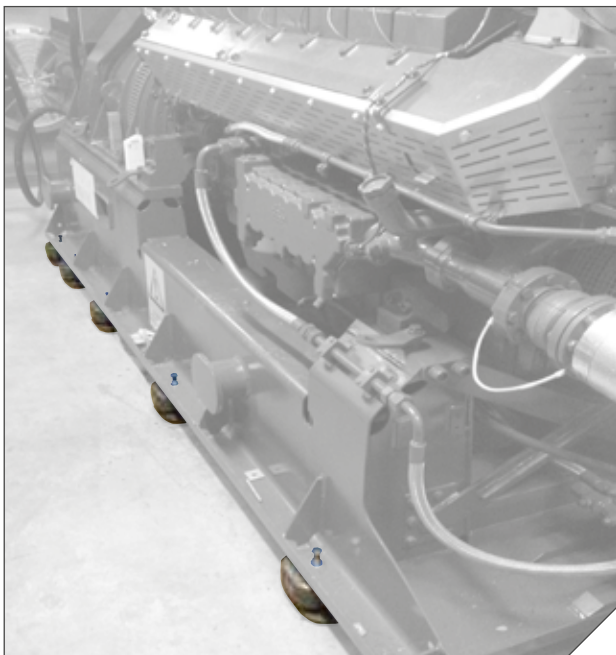

Max compression load in Kg deflection in mm.

This information is for guidance only. Customers are recommended to contact us for further technical information on products and applications. We reserve the right to alter specifications or withdraw products without notice.

Rectangular Sandwich Mountings

Sandwich mountings are a simple design whereby the rubber section is sandwiched between a top and bottom metal plate.

The mounting also incorporates an integrally bonded metal interleaf which increases the vertical stiffness and maximum load capacity of the mounting, whilst leaving the horizontal stiffness relatively unchanged.

The mountings can be used in Compression, Shear or a combination of both. For ultimate performance the mountings can be used in a "V" arrangement.



Advantages:

- High Vertical to Horizontal Stiffness Ratio
- Heavy Duty – up to 1000Kg per mounting
- High Performance – "V Arrangement "

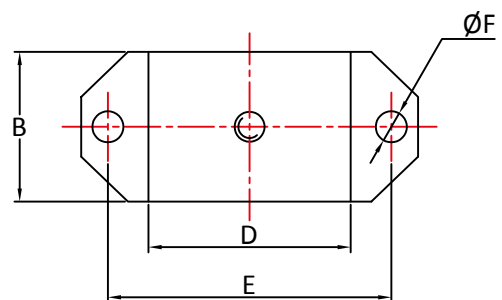
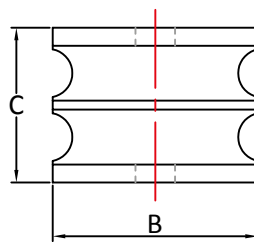

Applications:

- Engine mountings
- Generator sets
- Heavy plant
- Machinery
- Vibratory Screens

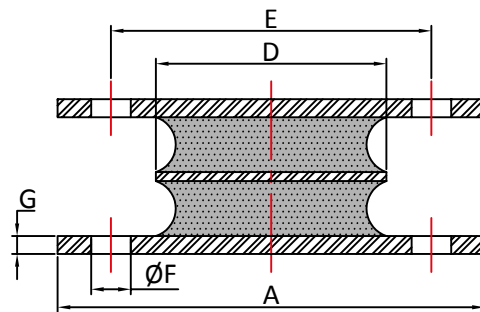

RSM332 RSM284 RSM242

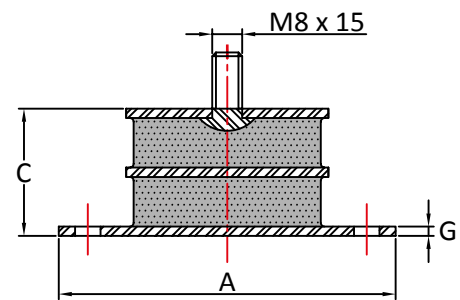

RSM406

| Part No | A mm | B mm | C mm | D mm | E mm | F mm | G mm | Kg | mm |
|-----------|------|------|------|------|------|------|------|------|-----|
| RSM406-45 | 90 | 40 | 36 | 54 | 74.5 | 6.8 | 3.5 | 95 | 2.8 |
| RSM406-50 | 90 | 40 | 36 | 54 | 74.5 | 6.8 | 3.5 | 135 | 2.8 |
| RSM406-60 | 90 | 40 | 36 | 54 | 74.5 | 6.8 | 3.5 | 200 | 2.8 |
| RSM406-70 | 90 | 40 | 36 | 54 | 74.5 | 6.8 | 3.5 | 310 | 2.8 |
| RSM322-45 | 110 | 57 | 43 | 64 | 89 | 11 | 5 | 190 | 3 |
| RSM322-60 | 110 | 57 | 43 | 64 | 89 | 11 | 5 | 375 | 3 |
| RSM322-70 | 110 | 57 | 43 | 64 | 89 | 11 | 5 | 500 | 2.6 |
| RSM284-45 | 127 | 57 | 43 | 84 | 108 | 11 | 5 | 300 | 3 |
| RSM284-60 | 127 | 57 | 43 | 84 | 108 | 11 | 5 | 600 | 3 |
| RSM284-70 | 127 | 57 | 43 | 84 | 108 | 11 | 5 | 800 | 2.6 |
| RSM242-45 | 168 | 57 | 43 | 127 | 146 | 11 | 5 | 450 | 3 |
| RSM242-60 | 168 | 57 | 43 | 127 | 146 | 11 | 5 | 850 | 2.8 |
| RSM242-70 | 168 | 57 | 43 | 127 | 146 | 11 | 5 | 1000 | 2.2 |

Max compression load in Kg deflection in mm.

This information is for guidance only. Customers are recommended to contact us for further technical information on products and applications. We reserve the right to alter specifications or withdraw products without notice.

Rail Mountings



Heavy Duty and Robust - Rail Mountings are ideal for supporting heavy plant and machinery. They can be supplied in up to 2 meters in length, with top and bottom metals, or bottom metal only. Suitable for use in Compression, Shear, or a combination of both.

Advantages:

- Can be cut to required size
- Fixing Holes can be drilled to suit
- High Load Capacity

Applications:

- Power Generation
- Pumps
- Heavy Plant & Machinery

Type 1 (Bottom metal only)

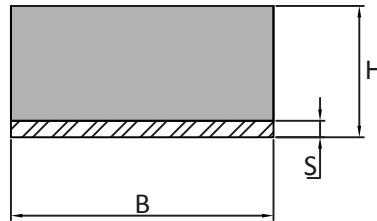

Type 2 (Top & Bottom metal)

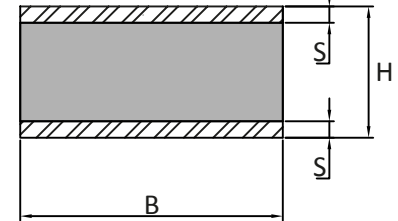

Rail Mountings can be supplied in lengths of up to 2 meters.

| Part No | B | H | S | | |
|---------|----|----|---|----|----|
| | | | 5 | 10 | 15 |
| RM2030 | 20 | 30 | ✓ | x | x |
| RM2525 | 25 | 25 | ✓ | ✓ | x |
| RM2530 | 25 | 30 | ✓ | ✓ | x |
| RM3020 | 30 | 20 | ✓ | ✓ | x |
| RM3030 | 30 | 30 | ✓ | ✓ | x |
| RM4020 | 40 | 20 | ✓ | ✓ | x |
| RM4030 | 40 | 30 | ✓ | ✓ | x |
| RM4040 | 40 | 40 | ✓ | ✓ | x |
| RM5030 | 50 | 30 | ✓ | ✓ | x |
| RM5040 | 50 | 40 | ✓ | ✓ | x |
| RM5050 | 50 | 50 | ✓ | ✓ | x |
| RM5060 | 50 | 60 | ✓ | ✓ | x |
| RM5070 | 50 | 70 | ✓ | ✓ | x |
| RM6020 | 60 | 20 | ✓ | ✓ | x |
| RM6030 | 60 | 30 | ✓ | ✓ | x |
| RM6040 | 60 | 40 | ✓ | ✓ | x |
| RM6050 | 60 | 50 | ✓ | ✓ | x |
| RM6060 | 60 | 60 | ✓ | ✓ | x |
| RM6070 | 60 | 70 | ✓ | ✓ | x |
| RM6080 | 60 | 80 | ✓ | ✓ | x |
| RM7030 | 70 | 30 | ✓ | ✓ | x |
| RM7040 | 70 | 40 | ✓ | ✓ | x |
| RM7050 | 70 | 50 | ✓ | ✓ | x |
| RM7060 | 70 | 60 | ✓ | ✓ | x |
| RM7070 | 70 | 70 | ✓ | ✓ | x |
| RM7080 | 70 | 80 | ✓ | ✓ | x |

| Part No | B | H | S | | |
|----------|-----|-----|---|----|----|
| | | | 5 | 10 | 15 |
| RM8040 | 80 | 40 | ✓ | ✓ | x |
| RM8045 | 80 | 45 | ✓ | ✓ | x |
| RM8060 | 80 | 60 | ✓ | ✓ | x |
| RM8080 | 80 | 80 | ✓ | ✓ | x |
| RM9045 | 90 | 45 | x | ✓ | ✓ |
| RM10040 | 100 | 40 | x | ✓ | ✓ |
| RM10050 | 100 | 50 | x | ✓ | ✓ |
| RM10060 | 100 | 60 | x | ✓ | ✓ |
| RM10070 | 100 | 70 | x | ✓ | ✓ |
| RM10080 | 100 | 80 | x | ✓ | ✓ |
| RM10090 | 100 | 90 | x | ✓ | ✓ |
| RM100100 | 100 | 100 | x | ✓ | ✓ |
| RM12045 | 120 | 45 | x | ✓ | ✓ |
| RM12050 | 120 | 50 | x | ✓ | ✓ |
| RM12060 | 120 | 60 | x | ✓ | ✓ |
| RM12070 | 120 | 70 | x | ✓ | ✓ |
| RM12080 | 120 | 80 | x | ✓ | ✓ |
| RM15050 | 150 | 50 | x | ✓ | ✓ |
| RM15060 | 150 | 60 | x | ✓ | ✓ |
| RM15070 | 150 | 70 | x | ✓ | ✓ |
| RM15080 | 150 | 80 | x | ✓ | ✓ |
| RM15090 | 150 | 90 | x | ✓ | ✓ |
| RM150100 | 150 | 100 | x | ✓ | ✓ |
| RM20060 | 200 | 60 | x | ✓ | ✓ |
| RM20080 | 200 | 80 | x | ✓ | ✓ |
| RM200100 | 200 | 100 | x | ✓ | ✓ |

Max compression load in Kg deflection in mm.

This information is for guidance only. Customers are recommended to contact us for further technical information on products and applications.

We reserve the right to alter specifications or withdraw products without notice.

Levelling Feet

Levelling Feet are simple, low cost products suitable for most types of machinery. They allow machinery to be levelled and also provide a degree of vibration and noise reduction. Additional sizes, Stainless Steel Metals, and Oil Resistant/High Temperature rubbers available on request.

Applications:

- Machine tools
- Lathes; Presses
- Heavy industrial equipment
- Conveyors
- Food processing

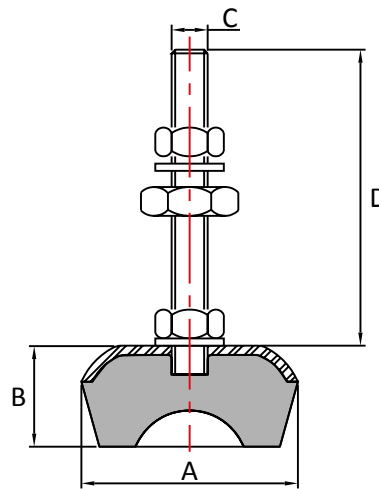

| Part No | A | B | C | D | Min Load (kg) | Max Load (kg) |
|-----------|-----|----|-----|-----|---------------|---------------|
| HARFSV000 | 45 | 23 | M8 | 48 | 20 | 80 |
| HARFSV00 | 60 | 28 | M10 | 81 | 60 | 120 |
| HARFSV0 | 70 | 34 | M12 | 89 | 90 | 160 |
| HARFSV1 | 85 | 32 | M12 | 89 | 130 | 350 |
| HARFSV2 | 100 | 40 | M14 | 109 | 270 | 600 |
| HARFSV3 | 120 | 50 | M16 | 116 | 450 | 900 |
| HARFSV4 | 140 | 50 | M16 | 116 | 700 | 1200 |
| HARFSV5 | 160 | 60 | M16 | 116 | 1100 | 1750 |
| HARFSV6 | 180 | 70 | M24 | 138 | 1500 | 2500 |
| HARFSV7 | 205 | 75 | M24 | 138 | 2100 | 3750 |

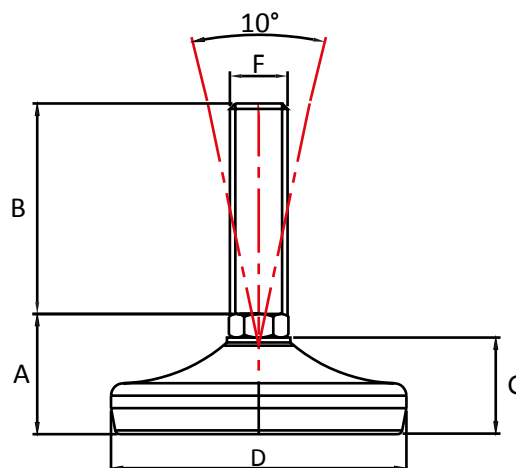

| Part No | G | B* | F* | D | A | Max Static Load (kg) |
|---------|----|----------------|-----------------|-----|------|----------------------|
| AVLF50 | 19 | min 50-150 max | min M10-M16 max | 50 | 29 | 400 |
| AVLF80 | 25 | min 50-200 max | min M10-M24 max | 80 | 35 | 1000 |
| AVLF100 | 30 | min 75-250 max | min M16-M30 max | 100 | 38.5 | 1500 |
| AVLF120 | 32 | min 75-250 max | min M16-M30 max | 120 | 42.5 | 3000 |

* Available with various thread sizes and lengths

Max compression load in Kg deflection in mm.

This information is for guidance only. Customers are recommended to contact us for further technical information on products and applications. We reserve the right to alter specifications or withdraw products without notice.

Adjustable Levelling Feet

Levelling Feet are simple, low cost products suitable for most types of machinery. They allow machinery to be levelled and also provide a degree of vibration and noise reduction. The KA and MFL mountings have an integral levelling feature.

Applications:

- Machine tools
- Lathes; Presses
- Heavy industrial equipment
- Conveyors
- Food processing

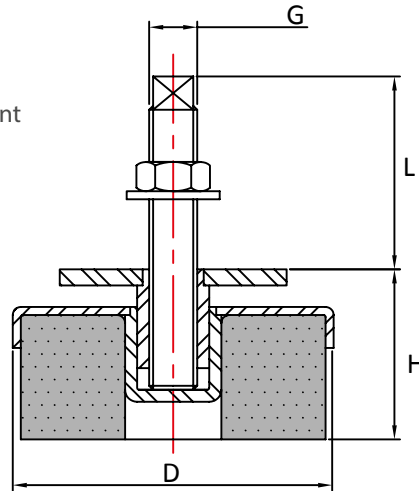

| Part No | D | H | G | L | Max Load (kg) |
|---------|-----|-------|-----|---------|---------------|
| MFL-1 | 80 | 38-48 | M12 | 65-75 | 500 |
| MFL-2 | 120 | 43-55 | M16 | 68-80 | 1000 |
| MFL-3 | 160 | 48-53 | M20 | 110-125 | 2000 |
| MFL-4 | 200 | 56-61 | M20 | 110-125 | 5500 |

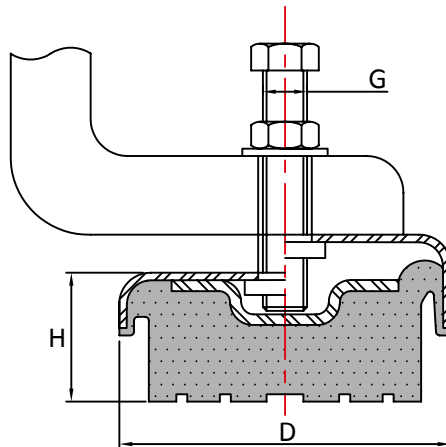

| Part No | D | H | G | Max Load (kg) |
|---------|-----|----|-------------|---------------|
| KA01 | 80 | 32 | M10/M12/M16 | 300 |
| KA090 | 90 | 35 | M12 | 400 |
| KA05 | 120 | 35 | M12/M16 | 800 |
| KA02 | 150 | 40 | M16 | 1000 |
| KA16 | 160 | 40 | M16/M20 | 1500 |
| KA03 | 200 | 45 | M20 | 3000 |

The KA Adjustable Levelling Feet are supplied without fixings

Max compression load in Kg deflection in mm.

This information is for guidance only. Customers are recommended to contact us for further technical information on products and applications. We reserve the right to alter specifications or withdraw products without notice.

Anti-Vibration Rubber Feet

Simple, economical and easy to install. Noise and Vibration Reduction Feet consist of a specially designed angled rubber section bonded to a steel plate. The Profile of the rubber base provides good levels of vibration reduction and increases the friction with the floor to stop equipment from “walking” during excessive vibration.

Applications:

- Scales and Weighing Equipment
- Portable Appliances
- Industrial and Domestic Equipment

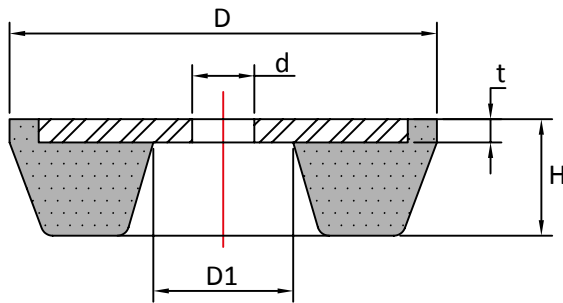

| Part No | D | D1 | d | H | t | Max Load (kg) |
|---------|-----|----|----|----|---|---------------|
| NVF75 | 55 | 18 | 8 | 15 | 3 | 150 |
| NVF250 | 75 | 25 | 10 | 17 | 4 | 400 |
| NVF750 | 115 | 40 | 14 | 24 | 4 | 1100 |

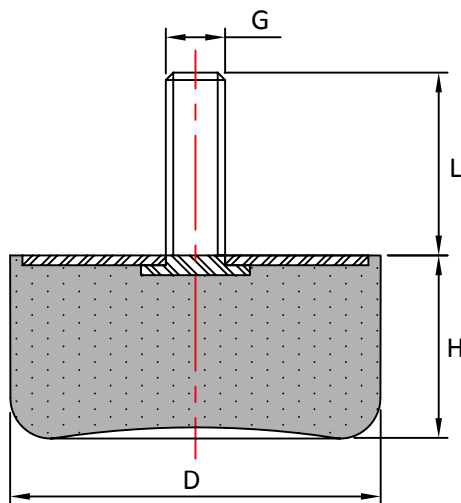

| Part No | D | H | G | L |
|-----------|----|------|-----|----|
| 1514MRF13 | 15 | 14 | M4 | 13 |
| 2024MFR18 | 20 | 23.5 | M6 | 18 |
| 2519MRF18 | 25 | 18.5 | M6 | 18 |
| 3029MRF20 | 30 | 28.5 | M8 | 20 |
| 4028MRF10 | 40 | 28 | M8 | 10 |
| 5028MRF33 | 50 | 28 | M10 | 33 |
| 7043MRF28 | 70 | 43 | M10 | 28 |
| 7537MRF37 | 75 | 37 | M12 | 37 |

Max compression load in Kg deflection in mm.

This information is for guidance only. Customers are recommended to contact us for further technical information on products and applications. We reserve the right to alter specifications or withdraw products without notice.

KG Block



KG Blocks are typically used for isolating Heavy Machinery from a buildings structure. They provide high levels of flexibility in both the vertical and horizontal direction, making them particularly suited to Low Frequency equipment. The design of the rectangular section allows them to be fitted under structural frames.

Advantages:

- Isolates Low Frequency Machines
- Ideal for Isolating Structures
- Wide Load Range

Applications:

- Floating Structures
- Concrete Inertia Bases
- Heavy Industrial Machinery
- Manufacturing Plants

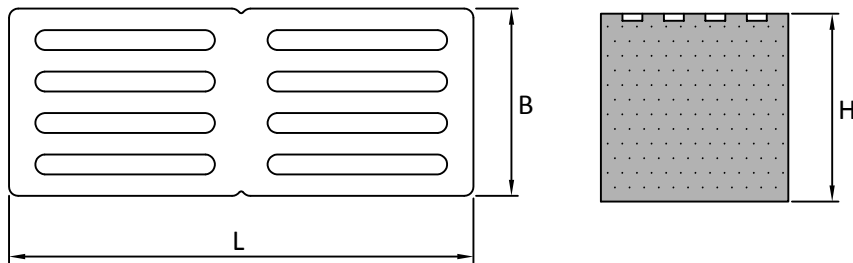

| Part No | L | B | H | Max Load (kg) |
|---------|-----|-----|-----|---------------|
| KG0-40 | 195 | 175 | 150 | 1,800 |
| KG0-60 | 195 | 175 | 150 | 3,800 |
| KG1-40 | 400 | 175 | 150 | 4,000 |
| KG1-60 | 400 | 175 | 150 | 8,000 |

Max compression load in Kg deflection in mm.

This information is for guidance only. Customers are recommended to contact us for further technical information on products and applications. We reserve the right to alter specifications or withdraw products without notice.

Spring Mountings

Spring Mountings are a High Performance Product, capable of achieving up to 99% Vibration Reduction. They are suitable for mounting Industrial Machinery, Power Generation, HVAC and Building Services Equipment, and come in two distinct types;

Enclosed Spring Mountings

Enclosed Spring Mountings consist of steel coil springs mounted within a steel cup. The Steel cup controls the lateral movement of the mounted equipment and also contains a snubbing ring to control start-up and shut-down movements. Ideal for Industrial Machinery. The mountings are supplied with a top fixing bolt to allow for levelling after installation, and can be supplied with an oil resistant anti-slip pad under the steel base.

Open Spring Mountings

Open Spring Mountings consist of a single coil spring mounted onto a fixing plate. They provide excellent vibration reduction properties, particularly for slow speed equipment such as Fans and HVAC equipment. The mountings can be supplied with an oil resistant anti-slip pad under the steel base.

Applications:

- Static Generating Sets
- HVAC (Fans, Pumps, AHU, Chillers)
- Slow Speed Equipment
- School, Hospital and Residential Installations



Max compression load in Kg deflection in mm.

This information is for guidance only. Customers are recommended to contact us for further technical information on products and applications. We reserve the right to alter specifications or withdraw products without notice.

Enclosed Spring Mountings

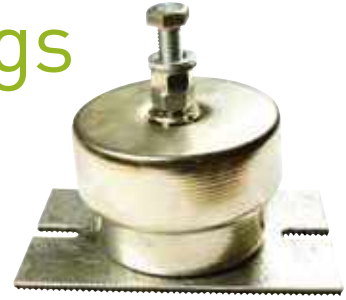
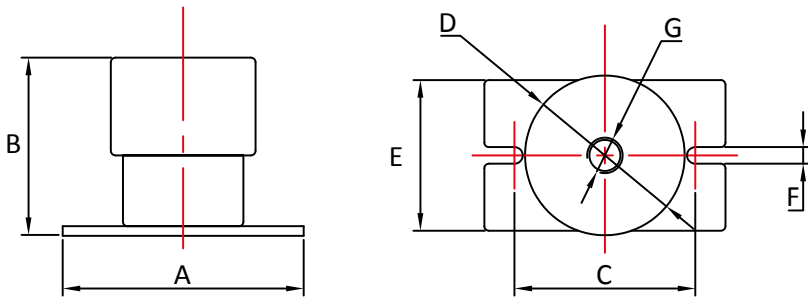

| Part No | A | B | C | D | E | F | G |
|---------|-----|-----|-----|-----|-----|----|-----|
| ESS | 75 | 73 | 59 | 55 | 40 | 10 | M8 |
| ESM | 150 | 79 | 120 | 105 | 100 | 10 | M12 |
| ESL | 230 | 80 | 200 | 175 | 150 | 12 | M12 |
| ESL-HD | 230 | 133 | 200 | 175 | 150 | 12 | M12 |

ESS

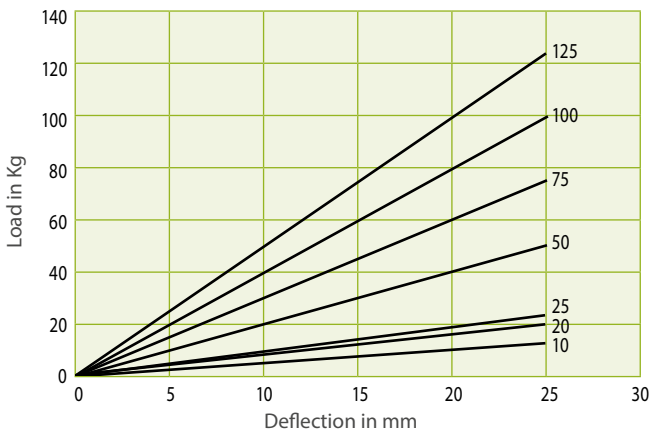

ESM

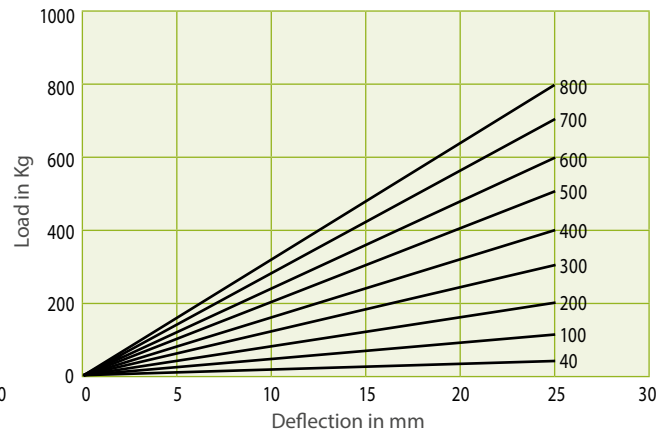

ESL

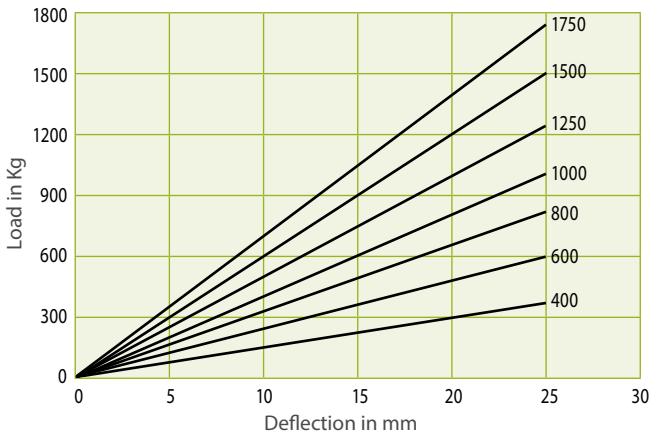

ESL-HD

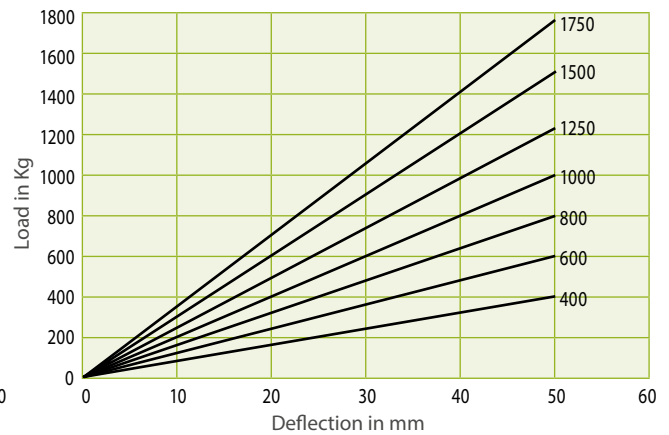

For normal working conditions it is recommended the mountings are loaded to a maximum of 20mm deflection (or 40mm ESL-HD version).

Max compression load in Kg deflection in mm.

This information is for guidance only. Customers are recommended to contact us for further technical information on products and applications. We reserve the right to alter specifications or withdraw products without notice.

Enclosed Spring Mountings

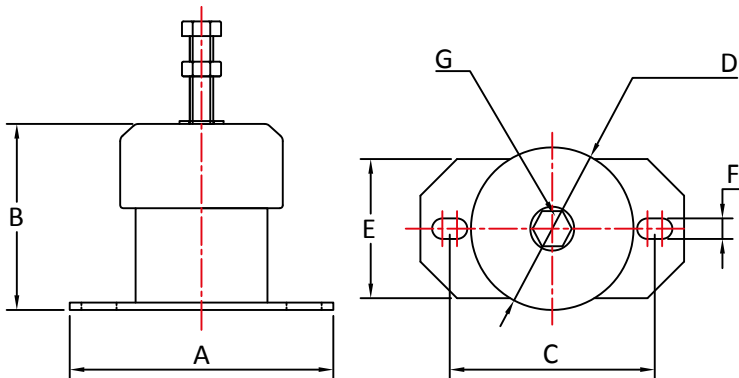

| Part No | A | B | C | D | E | F | G | Max Load (kg) | Deflection (mm) |
|------------|------|-----|---------|-----|----|------|-----|---------------|-----------------|
| ESS20/10 | 76 | 63 | 54-60 | 48 | 38 | 6.5 | M8 | 10 | 20 |
| ESS20/15 | | | | | | | | 15 | 20 |
| ESS20/20 | | | | | | | | 20 | 20 |
| ESS20/40 | | | | | | | | 40 | 20 |
| ESS20/70 | | | | | | | | 70 | 20 |
| ESS15/100 | | | | | | | | 100 | 15 |
| ESM25/30 | 110 | 89 | 85-90 | 78 | 70 | 9 | M10 | 30 | 25 |
| ESM25/60 | | | | | | | | 60 | 25 |
| ESM25/100 | | | | | | | | 100 | 25 |
| ESM25/160 | | | | | | | | 160 | 25 |
| ESM25/250 | | | | | | | | 250 | 25 |
| ESL25/100 | 180 | 127 | 130-150 | 111 | 95 | 13.5 | M16 | 100 | 25 |
| ESL25/200 | | | | | | | | 200 | 25 |
| ESL25/300 | | | | | | | | 300 | 25 |
| ESL25/400 | | | | | | | | 400 | 25 |
| ESL25/500 | | | | | | | | 500 | 25 |
| ESL25/600 | | | | | | | | 600 | 25 |
| ESL25/700 | | | | | | | | 700 | 25 |
| ESL25/800 | | | | | | | | 800 | 25 |
| ESL25/1000 | | | | | | | | 1000 | 25 |
| ESL25/1200 | | | | | | | | 1200 | 25 |
| ESL25/1400 | 1400 | 25 | | | | | | | |

MACHINERY MOUNTINGS

Max compression load in Kg deflection in mm.

This information is for guidance only. Customers are recommended to contact us for further technical information on products and applications. We reserve the right to alter specifications or withdraw products without notice.

Enclosed Spring Mountings Installation Instructions

The Enclosed Spring Mountings are suitable for static applications and incorporate a height adjusting device to allow the machine to be levelled during installation. Where possible mountings should be fitted on site, alternatively transit chocks should be fitted to the equipment during transportation.

The height adjusting bolts should be removed and all mountings placed in their correct floor position. The machine is now lowered into position, ensuring correct alignment of mounting fixing holes with brackets.

With lock nuts and washers fitted to the height adjusting bolts, they can now be screwed into the mounting fixing holes until a resistance is encountered.

The level of the machine can now be checked and if needed adjusted by screwing down the height adjusting bolts one or two turns at a time, in sequence at each mounting. When complete, the lock nuts should be locked in position.

If during start up or shut down the movement of the machine is considered excessive, snubbing of the movement can be increased by screwing down

the height adjusting bolts by equal amounts, one or two turns at a time, thereby raising the height of the mounting top cap which reduces the gap with the internal snubber ring.

Mountings should not be raised above their nominal unloaded height, if additional adjustment is required packing should be fitted to the top or to the bottom of the mounting.

For the mountings to isolate efficiently it is important that all connections and services to the machine should be flexible. The maximum hole size in the machine bracket should not give more than 2mm clearance on the bolt size. If the hole is larger, a suitable packing washer should be fitted below the machine bracket.

The Enclosed Spring mountings are pre-loaded during the manufacturing process and therefore have a nominal preload deflection. The deflections shown on the data sheet are "effective deflections" used for calculating the performance and percentage isolation. The actual deflection under load will be the effective deflection minus the preload.

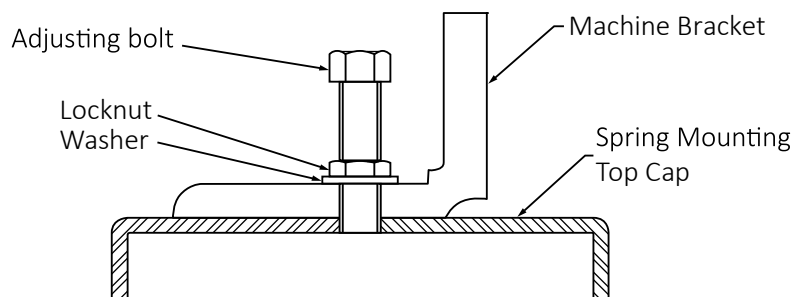

Max compression load in Kg deflection in mm.

This information is for guidance only. Customers are recommended to contact us for further technical information on products and applications. We reserve the right to alter specifications or withdraw products without notice.

Open Spring Mountings

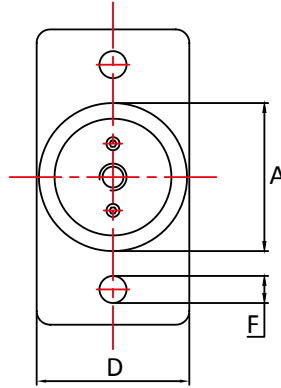
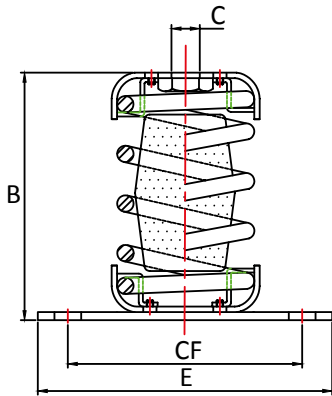

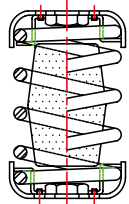
|  | Part No | Type | A | B | C | CF | D | E | F | Max Load (kg) | Deflection |
|---|---------------|--------|----|----|----|----|---|---|---|---------------|------------|
| | Type A | OSM5-A | A | 51 | 70 | M8 | - | - | - | - | 5 |
| | OSM15-A | A | 51 | 70 | M8 | - | - | - | - | 15 | 23 |
| | OSM25-A | A | 51 | 70 | M8 | - | - | - | - | 25 | 23 |
| | OSM50-A | A | 51 | 70 | M8 | - | - | - | - | 50 | 23 |
| | OSM75-A | A | 51 | 70 | M8 | - | - | - | - | 75 | 23 |
| | OSM100-A | A | 51 | 70 | M8 | - | - | - | - | 100 | 23 |
| | OSM125-A | A | 51 | 70 | M8 | - | - | - | - | 125 | 23 |

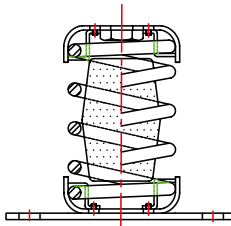
|  | Part No | Type | A | B | C | CF | D | E | F | Max Load (kg) | Deflection |
|---|---------------|--------|----|-----|-----|----|----|-----|-------|---------------|------------|
| | Type B | OSM5-B | B | 51 | 72 | M8 | 80 | 70 | 106 | 11x16 | 5 |
| | OSM15-B | B | 51 | 72 | M8 | 80 | 70 | 106 | 11x16 | 15 | 23 |
| | OSM25-B | B | 51 | 72 | M8 | 80 | 70 | 106 | 11x16 | 25 | 23 |
| | OSM50-B | B | 51 | 72 | M8 | 80 | 70 | 106 | 11x16 | 50 | 23 |
| | OSM75-B | B | 51 | 72 | M8 | 80 | 70 | 106 | 11x16 | 75 | 23 |
| | OSM100-B | B | 51 | 72 | M8 | 80 | 70 | 106 | 11x16 | 100 | 23 |
| | OSM125-B | B | 51 | 72 | M8 | 80 | 70 | 106 | 11x16 | 125 | 23 |
| | OSMHD100-B | B | 69 | 113 | M12 | 96 | 86 | 128 | 11x20 | 100 | 25 |
| | OSMHD125-B | B | 69 | 113 | M12 | 96 | 86 | 128 | 11x20 | 125 | 25 |
| | OSMHD150-B | B | 69 | 113 | M12 | 96 | 86 | 128 | 11x20 | 150 | 25 |
| | OSMHD200-B | B | 69 | 113 | M12 | 96 | 86 | 128 | 11x20 | 200 | 25 |
| | OSMHD250-B | B | 69 | 113 | M12 | 96 | 86 | 128 | 11x20 | 250 | 25 |
| | OSMHD300-B | B | 69 | 113 | M12 | 96 | 86 | 128 | 11x20 | 300 | 25 |
| | OSMHD400-B | B | 69 | 113 | M12 | 96 | 86 | 128 | 11x20 | 400 | 25 |
| | OSMHD500-B | B | 69 | 113 | M12 | 96 | 86 | 128 | 11x20 | 500 | 25 |
| | OSMHD600-B | B | 69 | 113 | M12 | 96 | 86 | 128 | 11x20 | 600 | 25 |
| | OSMHD700-B | B | 69 | 113 | M12 | 96 | 86 | 128 | 11x20 | 700 | 23 |
| | OSMHD800-B | B | 69 | 113 | M12 | 96 | 86 | 128 | 11x20 | 800 | 23 |

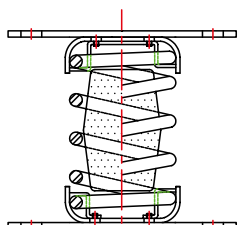
|  | Part No | Type | A | B | C | CF | D | E | F | Max Load (kg) | Deflection |
|---|---------------|--------|----|-----|----|----|----|-----|-------|---------------|------------|
| | Type C | OSM5-C | C | 51 | 73 | - | 80 | 70 | 106 | 11x16 | 5 |
| | OSM15-C | C | 51 | 73 | - | 80 | 70 | 106 | 11x16 | 15 | 23 |
| | OSM25-C | C | 51 | 73 | - | 80 | 70 | 106 | 11x16 | 25 | 23 |
| | OSM50-C | C | 51 | 73 | - | 80 | 70 | 106 | 11x16 | 50 | 23 |
| | OSM75-C | C | 51 | 73 | - | 80 | 70 | 106 | 11x16 | 75 | 23 |
| | OSM100-C | C | 51 | 73 | - | 80 | 70 | 106 | 11x16 | 100 | 23 |
| | OSM125-C | C | 51 | 73 | - | 80 | 70 | 106 | 11x16 | 125 | 23 |
| | OSMHD100-C | C | 69 | 115 | - | 96 | 86 | 128 | 11x20 | 100 | 25 |
| | OSMHD125-C | C | 69 | 115 | - | 96 | 86 | 128 | 11x20 | 125 | 25 |
| | OSMHD150-C | C | 69 | 115 | - | 96 | 86 | 128 | 11x20 | 150 | 25 |
| | OSMHD200-C | C | 69 | 115 | - | 96 | 86 | 128 | 11x20 | 200 | 25 |
| | OSMHD250-C | C | 69 | 115 | - | 96 | 86 | 128 | 11x20 | 250 | 25 |
| | OSMHD300-C | C | 69 | 115 | - | 96 | 86 | 128 | 11x20 | 300 | 25 |
| | OSMHD400-C | C | 69 | 115 | - | 96 | 86 | 128 | 11x20 | 400 | 25 |
| | OSMHD500-C | C | 69 | 115 | - | 96 | 86 | 128 | 11x20 | 500 | 25 |
| | OSMHD600-C | C | 69 | 115 | - | 96 | 86 | 128 | 11x20 | 600 | 25 |
| | OSMHD700-C | C | 69 | 115 | - | 96 | 86 | 128 | 11x20 | 700 | 23 |
| | OSMHD800-C | C | 69 | 115 | - | 96 | 86 | 128 | 11x20 | 800 | 23 |

Max compression load in Kg deflection in mm.

This information is for guidance only. Customers are recommended to contact us for further technical information on products and applications.

We reserve the right to alter specifications or withdraw products without notice.

Hangers

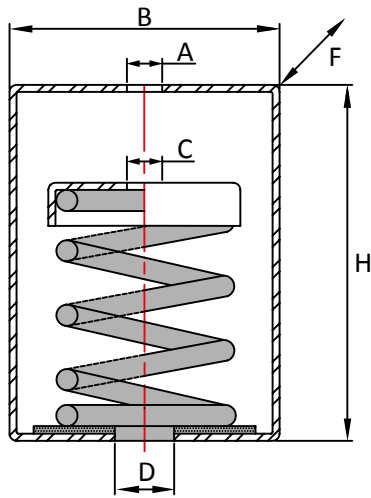

| Part No | B | F | H | A | D | C | Defl. mm | Max Kg |
|---------|-----|----|-----|----|----|----|----------|--------|
| TM 25 | 75 | 55 | 100 | 12 | 30 | 11 | 24 | 25 |
| TM 50 | 75 | 55 | 100 | 12 | 30 | 11 | 24 | 50 |
| TM 75 | 75 | 55 | 100 | 12 | 30 | 11 | 24 | 75 |
| TM 100 | 75 | 55 | 100 | 12 | 30 | 11 | 24 | 100 |
| TM 150 | 120 | 75 | 155 | 16 | 16 | 14 | 35 | 150 |
| TM 250 | 120 | 75 | 155 | 16 | 16 | 14 | 35 | 250 |
| TM 350 | 120 | 75 | 155 | 16 | 16 | 14 | 35 | 350 |

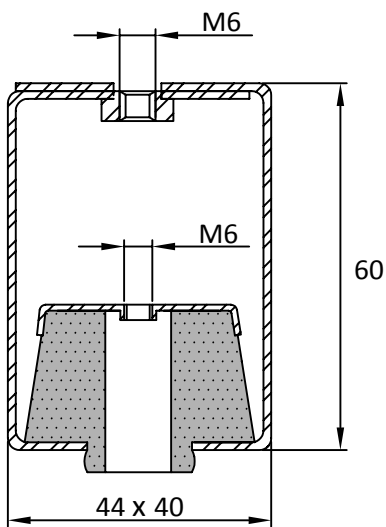

| Part No | Min kg | Max Kg |
|---------|--------|--------|
| TVAR 40 | 8 | 25 |
| TVAR 60 | 18 | 50 |
| TVAR 75 | 25 | 75 |

Max compression load in Kg deflection in mm.

This information is for guidance only. Customers are recommended to contact us for further technical information on products and applications. We reserve the right to alter specifications or withdraw products without notice.

Wire Rope Shock Mountings



Wire Rope Shock mountings are an “All Metal” design, providing multidirectional absorption of High Level Shock and Vibration. The all-metallic design allows these mountings to be used in extremely harsh conditions, including corrosive and high temperature environments.

The mountings can be manufactured in various designs and configurations, where the wire rope can be produced in Galvanised Steel or Stainless Steel, with load ranges from 0.1Kg to 5000Kg. Non-Magnetic Versions available on request.

Applications:

- Naval Vessels
- Military & Defence
- Aerospace
- Transit Packaging

Please contact the AV Technical Team to discuss your requirements.

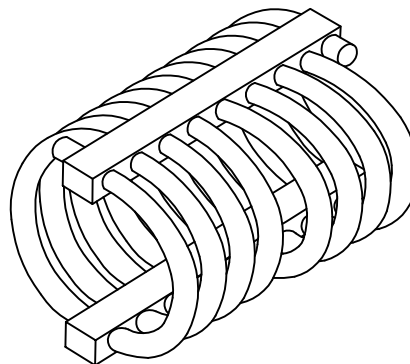
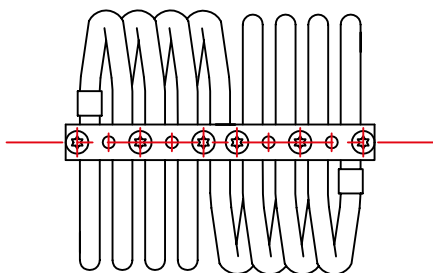
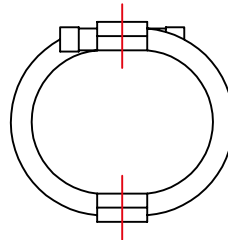
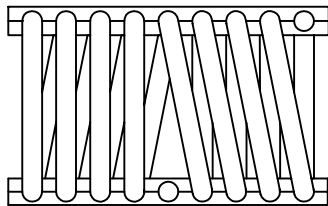

Max compression load in Kg deflection in mm.

This information is for guidance only. Customers are recommended to contact us for further technical information on products and applications. We reserve the right to alter specifications or withdraw products without notice.



INDUSTRIAL PRODUCTS

Notes

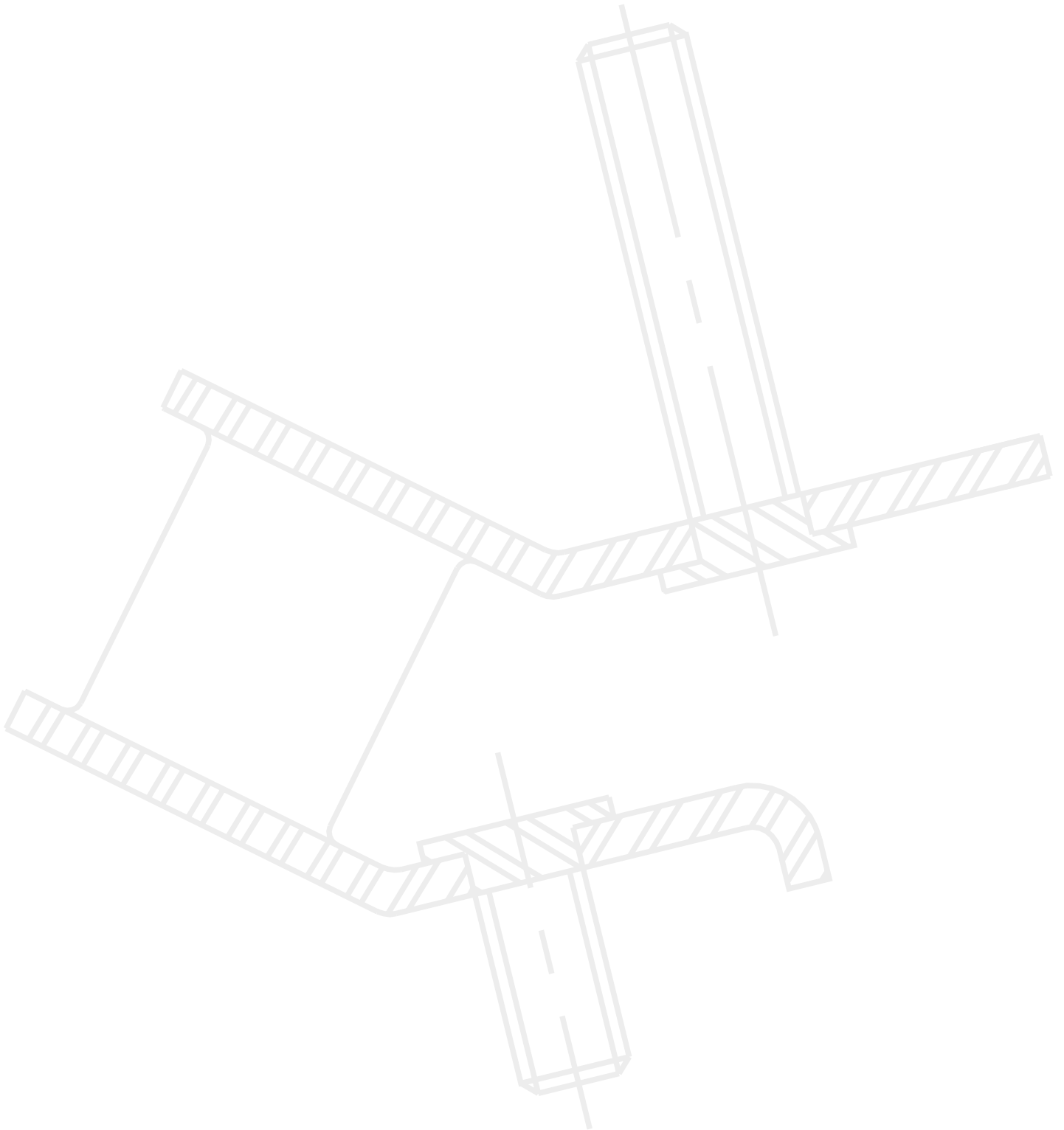



INDUSTRIAL PRODUCTS

Instrument Mountings

| | | | |
|-------------------------|----|------------------------------|----|
| Low Frequency Mountings | 62 | Plate and Pedestal Mountings | 68 |
| UU Shear Mountings | 63 | Suspended Mountings | 69 |
| Angle Mountings | 64 | Two Piece Mountings | 70 |
| L Shear Mountings | 64 | Grommet Mountings | 71 |
| W&V Mountings | 65 | T-Bushes | 72 |
| SF Mountings | 66 | Armoured Plate Two Piece | 73 |
| Cup Shock Mountings | 67 | Ring Elements | 74 |

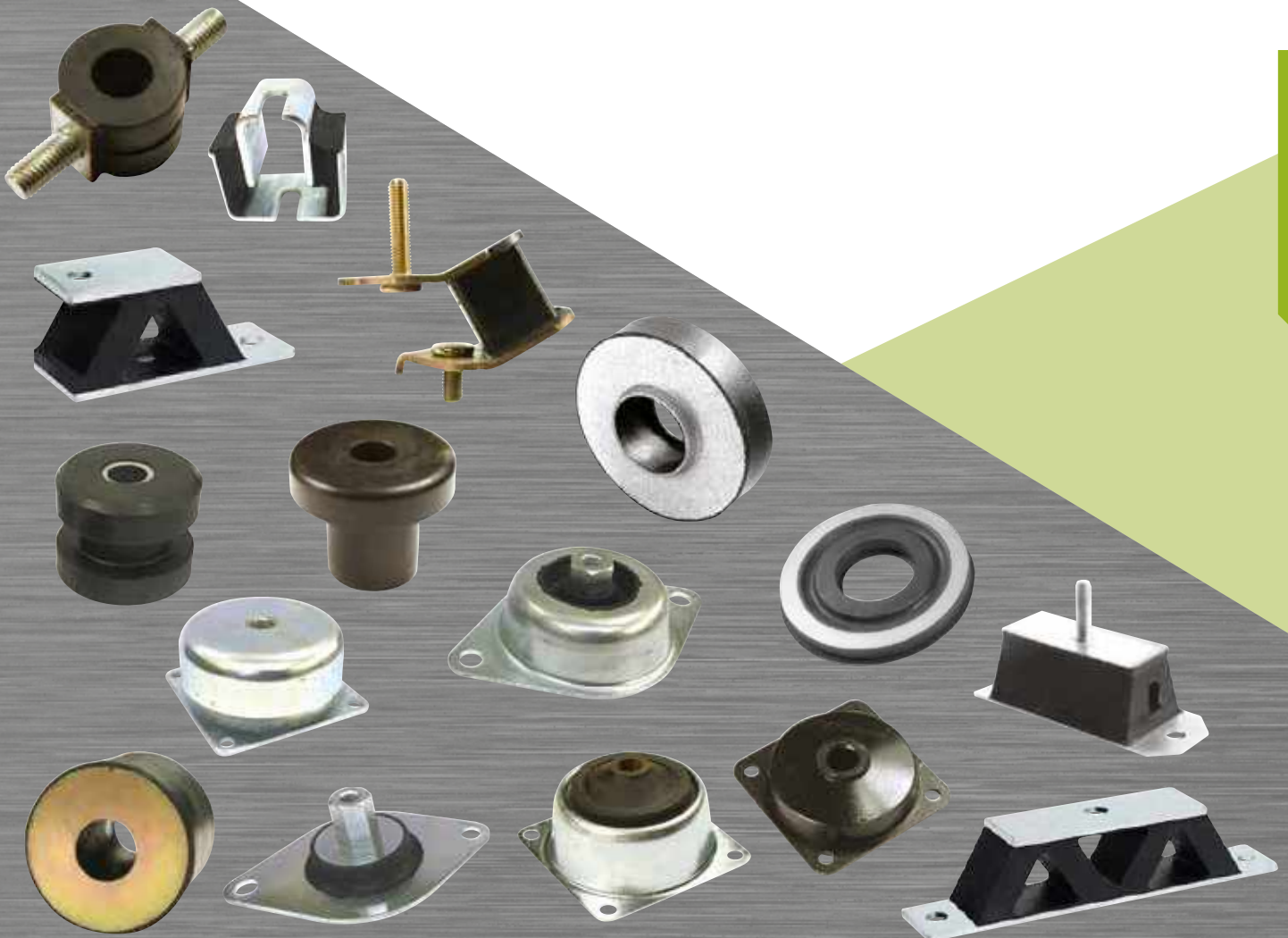

Low Frequency Mountings



High performance mountings for lightweight equipment. They are designed to give high levels of deflection under light loads, providing a low natural frequency and high levels of vibration isolation – both Active & Passive. They can be used in either compression, shear or a combination.

High Temperature & Oil Resistant Rubbers available on request.

Applications:

- Precision Equipment
- Sensitive Instruments
- Lightweight Machines
- Medical Equipment
- Sensors & Gauges

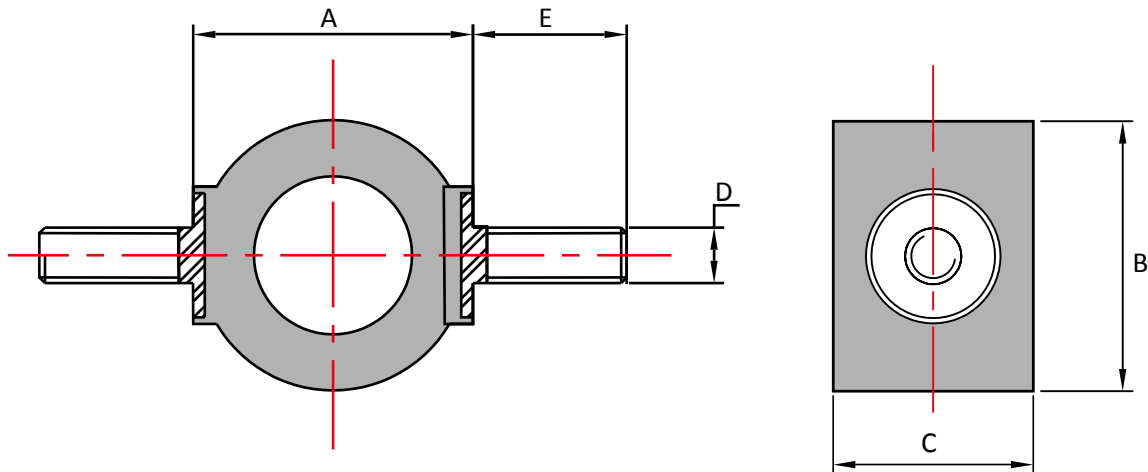

| Part No | A | B | C | D | E |
|---------|------|-----|-----|-----------|----|
| LF0912 | 12.5 | 9.5 | 9.4 | M4 | 10 |
| LF1394 | 17 | 14 | 14 | M4 | 10 |
| LF1395 | 30 | 25 | 19 | M5 | 10 |
| LF1396 | 38.5 | 35 | 25 | M6 (*M10) | 16 |

* Alternative Stud Size

Max compression load in Kg deflection in mm.

This information is for guidance only. Customers are recommended to contact us for further technical information on products and applications. We reserve the right to alter specifications or withdraw products without notice.

UU Shear Mountings



UU Shear mountings are designed to load the rubber in shear and thereby provide a soft vertical spring rate and high levels of vibration absorption.

They are also suitable for absorbing shock. They fall within two distinct ranges, those that have zinc plate metals and those that have the metals fully encapsulated in rubber.

Applications:

- Small Generators
- Fans
- Sensitive instruments & Apparatus
- Low Speed Machines
- Shock Protection

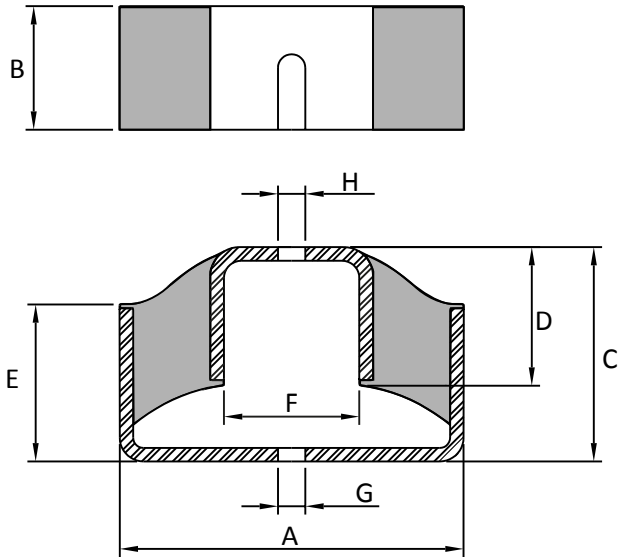

| Part No | A mm | B mm | C mm | D mm | E mm | F mm | G & H mm | Max Load kg | Deflection mm |
|-----------|------|------|------|------|------|------|----------|-------------|---------------|
| UU1492-40 | 61 | 20 | 43 | 25 | 27 | 20 | 6.6 | 14 | 8.0 |
| UU1492-50 | | | | | | | | 17 | 7.0 |
| UU1482-40 | 60 | 50 | 43 | 19 | 30 | 17 | 10 | 43 | 8.0 |
| UU1482-50 | | | | | | | | 50 | 7.5 |
| UU1481-40 | 70 | 25 | 62 | 37 | 43 | 25 | 10 | 17 | 8.0 |
| UU1481-50 | | | | | | | | 25 | 7.0 |
| UU1481-60 | | | | | | | | 28 | 4.5 |
| UU1480-40 | 80 | 50 | 78 | 50 | 55 | 30 | 13 | 72 | 8.0 |
| UU1480-50 | | | | | | | | 92 | 7.0 |
| UU1480-60 | | | | | | | | 95 | 4.5 |
| UU1479-40 | 86 | 64 | 108 | 76 | 82 | 38 | 16 | 152 | 8.0 |
| UU1479-50 | | | | | | | | 170 | 6.0 |
| UU1479-60 | | | | | | | | 205 | 4.0 |

| Part No | A mm | B mm | C mm | D mm | E mm | F mm | G & H mm | Max Load kg | Deflection mm |
|-----------|------|------|------|------|------|------|----------|-------------|---------------|
| UU20-40* | 90 | 20 | 50 | 34 | 34 | 39 | 10 | 20 | 6.0 |
| UU20-60* | | | | | | | | 35 | 5.0 |
| UU20-70* | | | | | | | | 50 | 5.0 |
| UU50-40* | 90 | 50 | 50 | 34 | 34 | 39 | 12 | 60 | 6.2 |
| UU50-60* | | | | | | | | 110 | 5.6 |
| UU50-70* | | | | | | | | 160 | 5.6 |
| UU100-40* | 90 | 100 | 50 | 34 | 34 | 39 | 15 | 130 | 6.8 |
| UU100-60* | | | | | | | | 250 | 6.8 |
| UU100-70* | | | | | | | | 360 | 6.8 |

*Full encapsulated with rubber

Max compression load in Kg deflection in mm.

This information is for guidance only. Customers are recommended to contact us for further technical information on products and applications. We reserve the right to alter specifications or withdraw products without notice.

Angle Mountings

Angle Mountings are used in pairs – diametrically opposite to give a low roll frequency and hence improved vibration isolation whilst maintaining good stability of the equipment.

Applications:

- Portable Generators
- Compressors
- Pumps

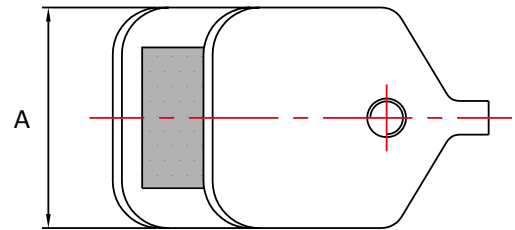
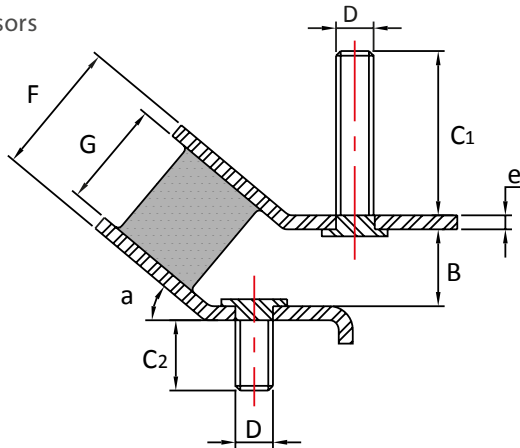
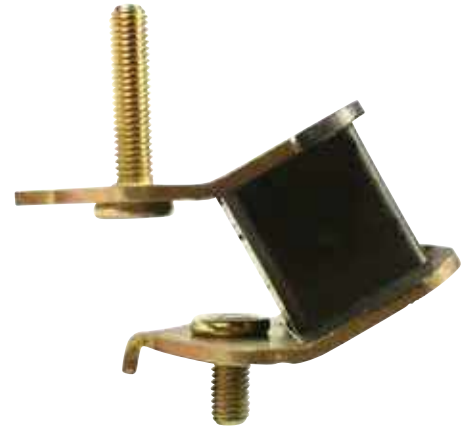

| Part No | A | B | D | C ₁ | C ₂ | e | a | F | G | 45° Shore A | | 60° Shore A | |
|---------|----|----|----|----------------|----------------|---|-----|----|------|-------------|----|-------------|----|
| | | | | | | | | | | Kg | mm | Kg | mm |
| AM47 | 47 | 17 | M8 | 35 | 15 | 3 | 40° | 29 | 23.0 | 5 | 5 | 15 | 5 |
| AM54 | 54 | 19 | M8 | 35 | 15 | 3 | 40° | 37 | 31.0 | 40 | 9 | 90 | 9 |

L Shear Mountings

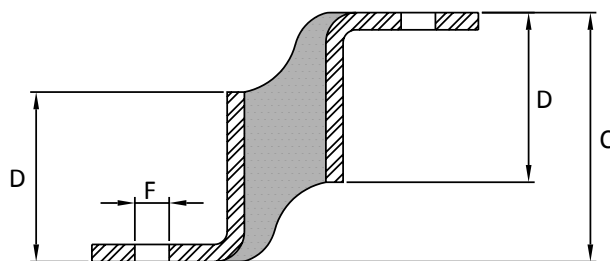
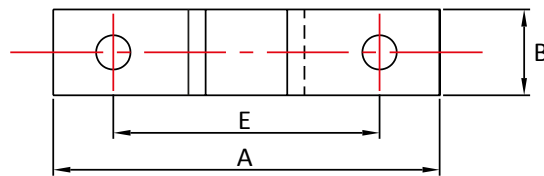

| Part No | A | B | C | D | E | F | Max Load (kg) | | |
|---------|----|----|----|----|----|---|---------------|-------------|-------------|
| | | | | | | | 40° Shore A | 60° Shore A | 70° Shore A |
| L20-2 | 90 | 20 | 58 | 40 | 62 | 8 | 12 | 27 | 39 |

Max compression load in Kg deflection in mm.

This information is for guidance only. Customers are recommended to contact us for further technical information on products and applications. We reserve the right to alter specifications or withdraw products without notice.

W & V Mountings

W and V type mountings are ideal for use in both compression and shear. The profile of the rubber section allow for high levels of deflection to be achieved at low loads.

Advantages:

- Ideal for Lightweight Equipment
- Protect Sensitive Equipment from Shock
- Easy to Install

Applications:

- Small Generators
- Slow Speed Machines (Fans etc)
- Electronics
- Shock Protection Units

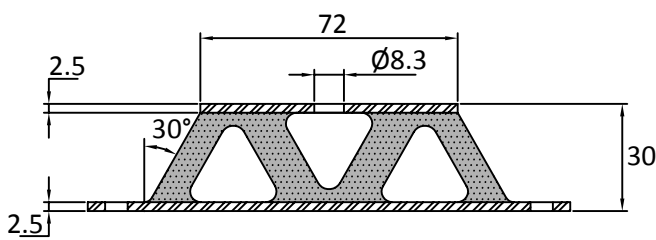
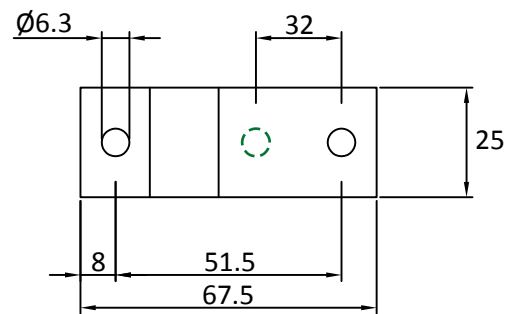
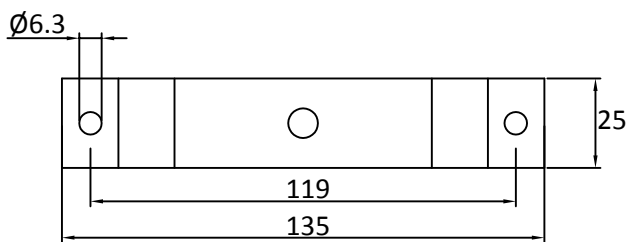

W Mount

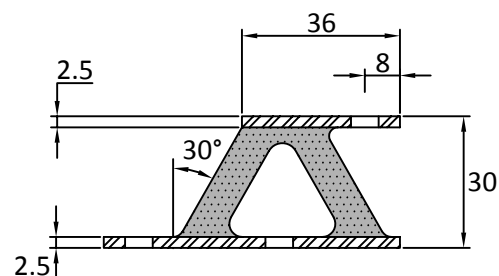

V Mount

| Part No | Compression | | Shear | |
|----------|-------------|-----|-------------|----|
| | Max Load Kg | mm | Max Load Kg | mm |
| W7230-40 | 40 | 5 | 19 | 10 |
| W7230-55 | 65 | 5 | 30 | 10 |
| W7230-70 | 100 | 5 | 48 | 10 |
| V3630-40 | 17 | 5 | 7.5 | 10 |
| V3630-55 | 30 | 5 | 19 | 10 |
| V3630-70 | 40 | 4.8 | 25 | 10 |

Max compression load in Kg deflection in mm.

This information is for guidance only. Customers are recommended to contact us for further technical information on products and applications. We reserve the right to alter specifications or withdraw products without notice.

SF Mountings

A general purpose and versatile anti-vibration mounting which can be used in a variety of different applications. The circular relief within the rubber section enables the SF mountings to provide good levels of vibration attenuation and shock absorption.



Applications:

- Diesel engines
- Pumps
- Compressors
- Motors
- General industrial machinery

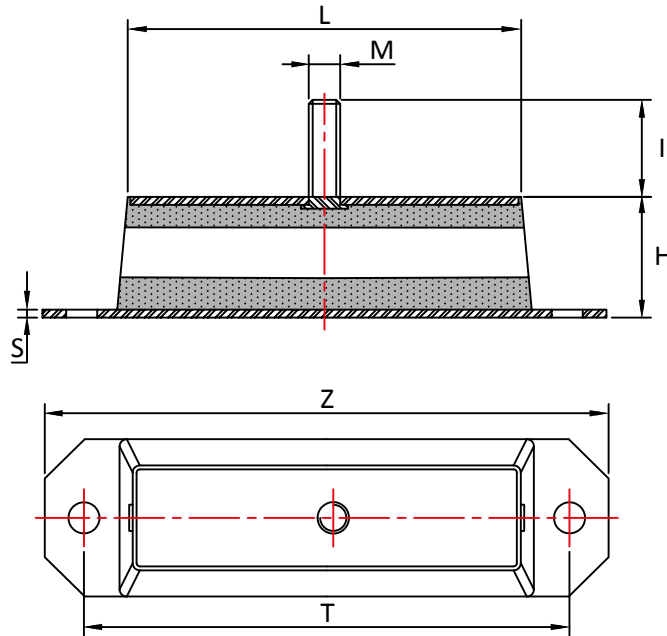

| Part No | Z | L | T | H | M | I | S | Max Load Kg |
|---------|-----|-----|-----|------|-----|----|---|-------------|
| SF50 | 115 | 50 | 85 | 45.7 | M12 | 37 | 3 | 150 |
| SF100 | 165 | 100 | 135 | 45.7 | M12 | 37 | 3 | 320 |
| SF150 | 215 | 150 | 185 | 45.7 | M12 | 37 | 3 | 460 |
| SF200 | 265 | 200 | 235 | 45.7 | M12 | 37 | 3 | 620 |

Max compression load in Kg deflection in mm.

This information is for guidance only. Customers are recommended to contact us for further technical information on products and applications. We reserve the right to alter specifications or withdraw products without notice.

Cup Shock Mountings



Cup Shock mountings are a relatively stiff product, ideal for applications where high frequency vibrations are predominant. The product is failsafe and ideal for both mobile and static applications. The outer metal cap offers protection from contaminants such as Oil and Fuel. The design of the mounting also allows the product to be used in tension, although maximum loads should be derated.

Advantages:

- Failsafe Design
- Ideal for High Frequency Vibration
- Excellent Shock Absorption
- Can be used in Compression or Tension

Applications:

- Military Equipment
- Electronics
- HVAC
- Motors & Compressors

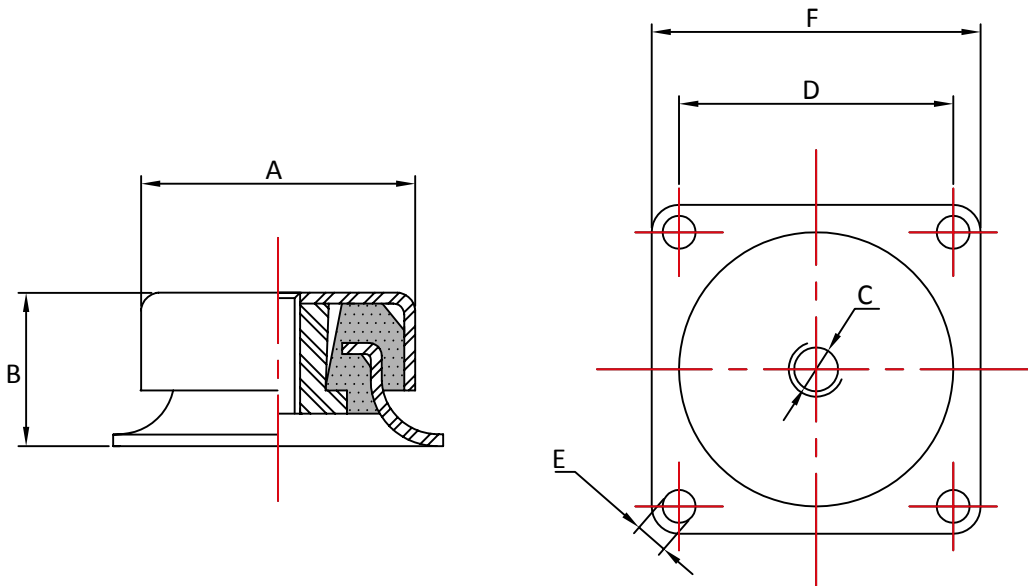

| Part No | A | B | C | D | E | F |
|---------|----|----|-----|------|-----|----|
| CSM1000 | 50 | 28 | M8 | 50 | 6 | 60 |
| CSM2000 | 76 | 38 | M10 | 63.5 | 6.7 | 76 |

| Part No | 45 Shore A | | 60 Shore A | | 75 Shore A | |
|---------|------------|-----|------------|-----|------------|-----|
| | KG | mm | KG | mm | KG | mm |
| CSM1000 | 80 | 2 | 100 | 1.5 | 150 | 1.5 |
| CSM2000 | 180 | 2.5 | 240 | 2.5 | 300 | 2.0 |

Max compression load in Kg deflection in mm.

This information is for guidance only. Customers are recommended to contact us for further technical information on products and applications. We reserve the right to alter specifications or withdraw products without notice.

Plate and Pedestal Mountings

Plate & Pedestal mountings are ideal for lightweight equipment due to their low stiffness. They are available as either a "Plate Mounting" or "Pedestal Mounting" option, and can be made failsafe by fitting top and bottom washers.



Applications:

- Control Panels
- Sensitive Instruments
- Radiators
- Marine Equipment
- Fans
- Blowers

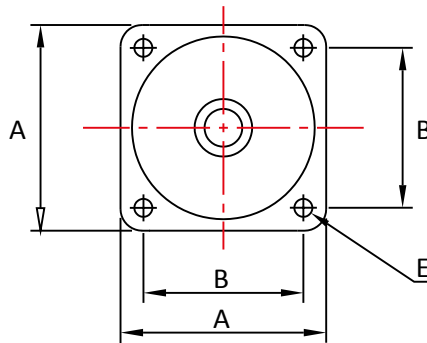
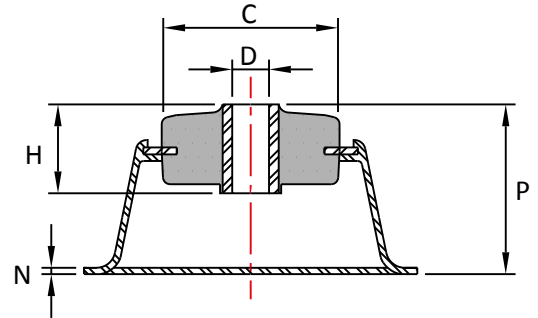
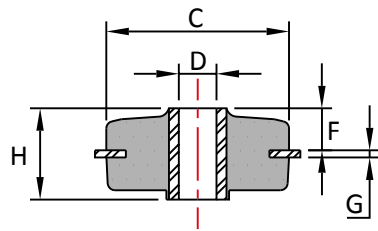
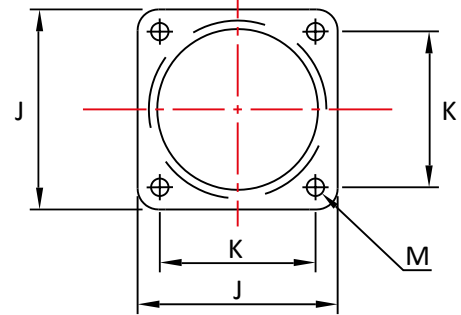

Plate Mount



Pedestal Mount

| Part No | A | B | C | D | E | F | G | H | J | K | M | N | P |
|---------|-------|------|------|------|------|------|------|------|---|---|---|---|---|
| PL1800 | 31.75 | 25.4 | 25.4 | 4.20 | 3.60 | 6.70 | 0.80 | 10.3 | - | - | - | - | - |
| PL1801 | 44.5 | 34.9 | 38.1 | 6.5 | 4.2 | 8.9 | 1.3 | 15.9 | - | - | - | - | - |
| PL1802 | 57.2 | 44.5 | 50.8 | 9.9 | 5.0 | 13.5 | 1.5 | 25.4 | - | - | - | - | - |

| | | | | | | | | | | | | | |
|--------|---|---|------|------|---|---|---|------|------|------|------|------|------|
| PE1803 | - | - | 25.4 | 4.20 | - | - | - | 10.3 | 42.9 | 34.9 | 3.60 | 0.60 | 19.8 |
| PE1804 | - | - | 38.1 | 6.5 | - | - | - | 15.9 | 60.3 | 49.2 | 5.0 | 0.8 | 28.6 |
| PE1805 | - | - | 50.8 | 9.9 | - | - | - | 25.4 | 76.0 | 63.5 | 6.5 | 0.94 | 39.7 |

| Part No | | Maximum Load (kg) | Deflection (mm) at Maximum Load |
|-----------|-----------|-------------------|---------------------------------|
| Plate | Pedestal | | |
| PL1800-45 | PE1803-45 | 0.91 | 1.6 |
| PL1800-60 | PE1803-60 | 1.8 | 1.6 |
| PL1801-45 | PE1804-45 | 2.7 | 2.5 |
| PL1801-60 | PE1804-60 | 5.4 | 2.5 |
| PL1801-70 | PE1804-70 | 8.2 | 2.5 |
| PL1802-45 | PE1805-45 | 14 | 3 |
| PL1802-60 | PE1805-60 | 23 | 3 |
| PL1802-70 | PE1805-70 | 40 | 3 |

Max compression load in Kg deflection in mm.

This information is for guidance only. Customers are recommended to contact us for further technical information on products and applications. We reserve the right to alter specifications or withdraw products without notice.

Suspended Mounts



The Suspended Mountings are ideal for hanging or suspending equipment from walls, vertical surfaces, ceilings or supporting structures. The HNG Upper is used to accommodate tensile mounted loads at the top fixing of the equipment, whilst the HNG Lower is used to accommodate the compressive loads at the bottom of the equipment.

Advantages:

- Fail Safe Design
- Easy to Install
- Suspends from Ceilings & Walls

Applications:

- HVAC
- Ducting and Pipework
- Instrument Cabinets
- Control panels

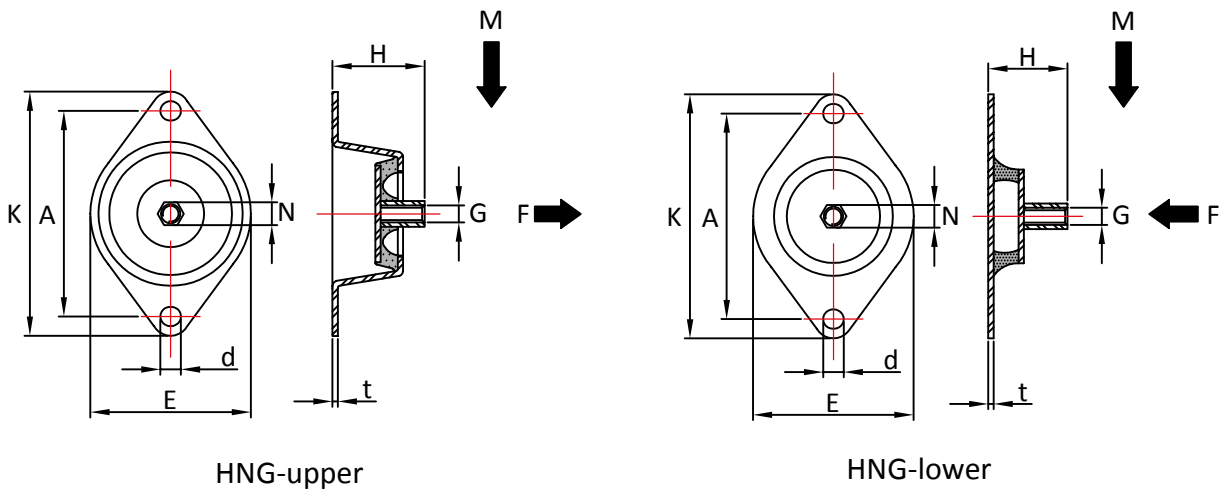
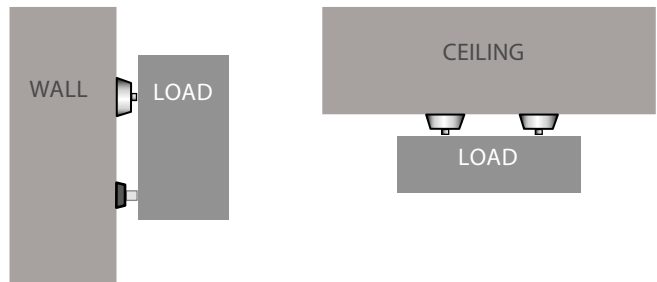

| TYPE | E | K | A | H | d | N | t | G |
|-----------|----|-----|----|----|---|----|-----|----|
| HNG-upper | 75 | 114 | 96 | 33 | 9 | 15 | 2.5 | M8 |
| HNG-lower | 75 | 114 | 96 | 33 | 9 | 15 | 2.5 | M8 |

| TYPE | M-Max (KG) | | F-Max (KG) | |
|-----------|------------|--------|------------|--------|
| | 40° Sh | 60° Sh | 40° Sh | 60° Sh |
| HNG-upper | 14 | 25 | 30 | 70 |
| HNG-lower | 14 | 25 | 30 | 70 |

Max compression load in Kg deflection in mm.

This information is for guidance only. Customers are recommended to contact us for further technical information on products and applications. We reserve the right to alter specifications or withdraw products without notice.

Two Piece Mountings



Two Piece mountings are an ideal product for reducing vibration and accommodating high shock forces. They are also used to allow flexibility within an installation to reduce stress on brackets and fabrications.

Two Piece mountings are suitable for both Static and Mobile applications, and should be installed with top and bottom washers to provide a failsafe installation.

Applications:

- Construction Equipment
- Power Generation
- Military Vehicles
- Off-Road Vehicles
- Agricultural Equipment
- Radiators

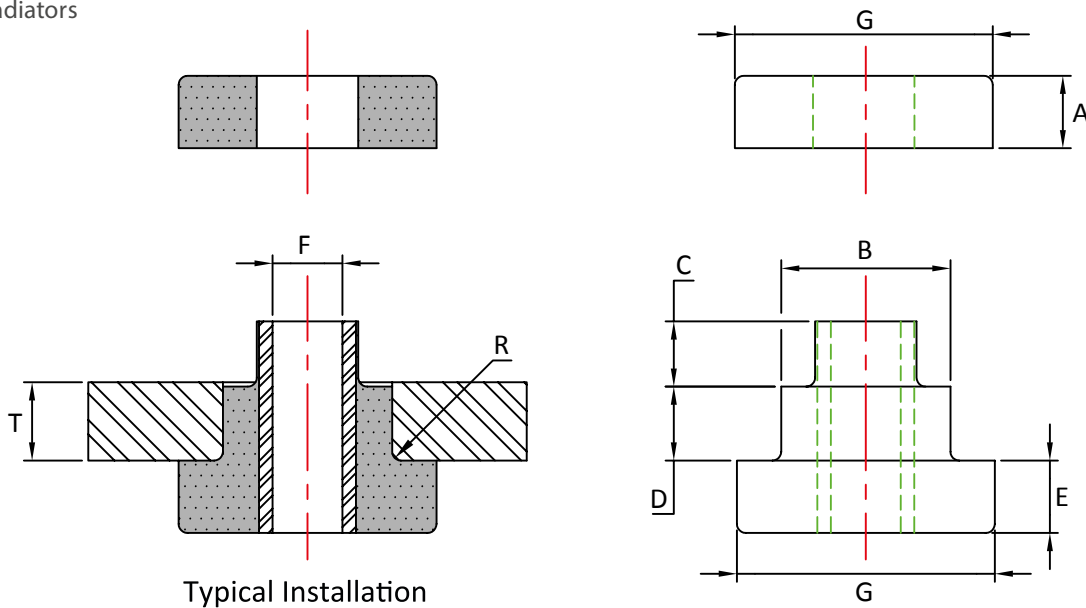

| Part No | A | B | C | D | E | F | G | R | Tmax | Tmin | Max Load (at Tmax) | |
|------------|------|------|------|-----|------|-------|------|-----|------|------|--------------------|-------------|
| | | | | | | | | | | | 45° Shore A | 60° Shore A |
| TP3035 | 12.3 | 20.1 | 10.3 | 9.3 | 12.3 | 10.3 | 33 | 1 | 9.5 | 9.5 | 40 | 110 |
| TP4850 | 20 | 31 | 19 | 10 | 20 | 13.5 | 47.5 | 1.5 | 14 | 12.5 | 80 | 130 |
| TP2203 | 22.5 | 39.5 | 24 | 15 | 23 | 16.5 | 64 | 2.5 | 22 | 19 | 120 | 260 |
| TP9075 | 25 | 58.4 | 26.5 | 22 | 25 | 24.1 | 89 | 3 | 28.6 | 25.4 | 260 | 450 |
| TP3520 | 7.5 | 22.6 | 5 | 4.9 | 7.5 | 10.35 | 35 | 1 | 6 | 6 | 42 | 84 |
| TP3520W10* | 9 | 22.6 | 6.5 | 3.5 | 9 | 10.2 | 35 | 2 | 4 | 4 | 42 | 84 |
| TP3025 | 12.3 | 20.1 | 10.3 | 2.5 | 12.3 | 10.3 | 33 | 1 | 5 | 5 | 35 | 75 |

*with intergrated bonded washers

Max Load should be derated by 25% for off highway and high dynamic applications

Max compression load in Kg deflection in mm.

This information is for guidance only. Customers are recommended to contact us for further technical information on products and applications. We reserve the right to alter specifications or withdraw products without notice.

Grommet Mountings



Grommet mountings are normally used as a simple fastening method or to isolate high frequency vibrations. They can be installed in several configurations, such as through brackets or into blind holes, as can be shown in the below Installation diagram.

Applications:

- Vehicle & Machinery Body Panels
- Motorcycle Fairing
- Lightweight Equipment
- Electronics & CPU's
- Sensors & Gauges

Installation Options

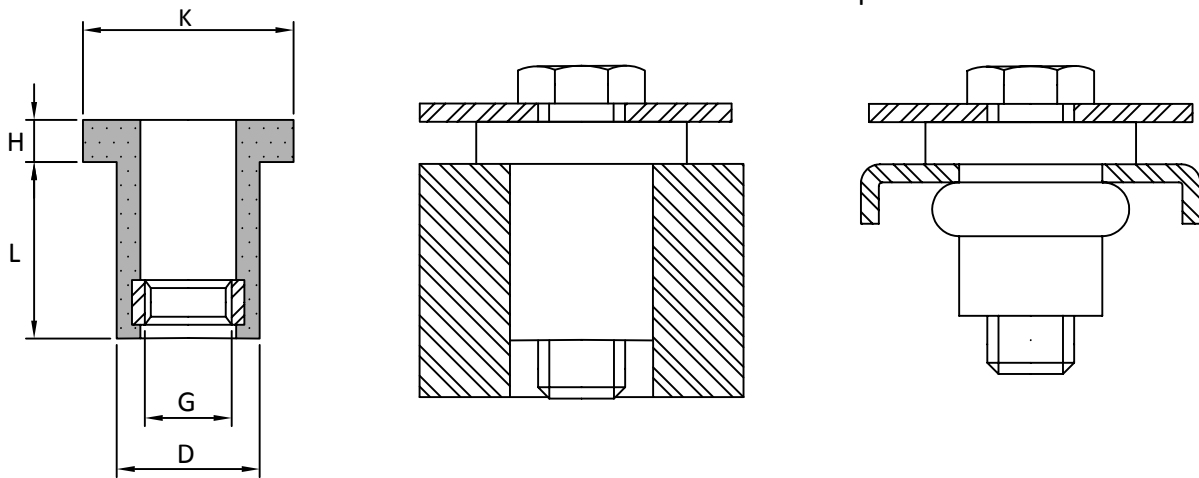

| Part No | D | K | L | H | G |
|---------|------|----|------|-----|----|
| GM09 | 7.2 | 9 | 9 | 2.5 | M3 |
| GM12 | 9.3 | 12 | 11.5 | 3 | M4 |
| GM15 | 10.2 | 15 | 14.5 | 3.5 | M5 |
| GM18 | 12.7 | 18 | 17 | 4 | M6 |
| GM24 | 16.5 | 24 | 22 | 5 | M8 |

Max compression load in Kg deflection in mm.

This information is for guidance only. Customers are recommended to contact us for further technical information on products and applications. We reserve the right to alter specifications or withdraw products without notice.

T-Bushes



T-Bushes offer a low cost solution for isolating vibration, reducing structure borne noise, and absorbing shock forces for both mobile & static applications. Using Overload and Rebound washers provide a failsafe installation. The mountings also have the benefit of a low profile height.

Applications:

- Fuel Tanks
- Radiators
- Pumps
- Industrial Equipment

Installation

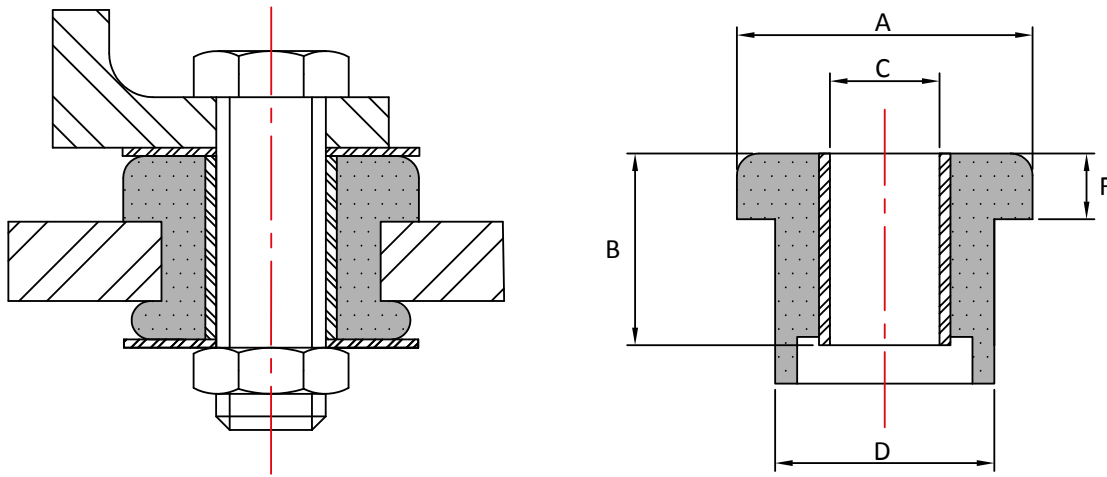

| Part No | A | B | C | D | F | Kg | mm |
|---------|------|------|------|------|------|-----|------|
| TB25 | 27 | 17.5 | 10 | 20 | 6 | 50 | 0.7 |
| TB12 | 31.8 | 27.2 | 10.2 | 24.1 | 14 | 50 | 1.4 |
| TB45 | 43 | 25 | 13 | 31 | 10 | 100 | 1.2 |
| TB50 | 49 | 35 | 13 | 34 | 13 | 200 | 1.6 |
| TB60 | 63 | 30 | 16 | 41 | 15 | 250 | 2 |
| TB65 | 63 | 44 | 16 | 41 | 15 | 250 | 2 |
| TB75 | 75.5 | 50.8 | 16.3 | 50.3 | 20.6 | 340 | 2.16 |
| TBCBA20 | 50.8 | 36.8 | 13.5 | 35.1 | 19.1 | 181 | 2.5 |
| TBCBA24 | 59.7 | 38.1 | 16 | 38.1 | 17.5 | 295 | 2.5 |
| TBCBA28 | 71.1 | 41.4 | 20 | 41.1 | 17.5 | 476 | 2.5 |
| TBCBA33 | 83.8 | 49.3 | 20 | 41.1 | 22.4 | 725 | 3 |

Max compression load in Kg deflection in mm.

This information is for guidance only. Customers are recommended to contact us for further technical information on products and applications. We reserve the right to alter specifications or withdraw products without notice.

Armoured Plate Two Piece



Armoured Plate Mountings are used to allow flexibility within an installation and reduce stress on brackets and fabrications. They are typically used in pairs, on opposing sides of a bracket, to allow for vibration isolation in the positive and negative direction.

The mountings have an integral wear plate that avoids premature failure due to frictional wear between the rubber and the mounting bracket. It is recommended that a shouldered or plain shank bolt is used to ensure that mounting is not over-compressed during assembly.

Applications:

- Construction Equipment
- Power Generation
- Military Vehicles
- Off-Road
- Agricultural
- Radiators

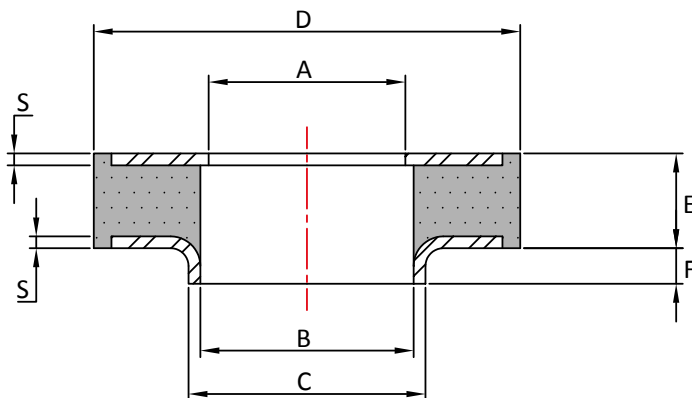
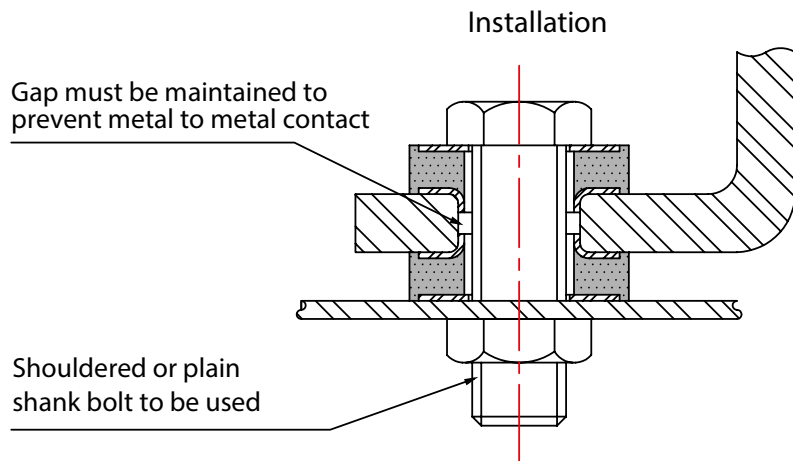

| Part No | Dimensions in mm | | | | | | | Compression | | |
|-------------|------------------|------|------|----|----|------|-----|---------------|-------------|-------------|
| | | | | | | | | Max Load (kg) | | |
| | D | A | B | C | E | F | S | 45° Shore A | 60° Shore A | 70° Shore A |
| ATP3615166 | 36 | 6 | 6 | 15 | 16 | 6 | 1 | 97 | 163 | 265 |
| ATP3615106 | 36 | 6.2 | 6.2 | 15 | 10 | 6 | 1 | 97 | 163 | 265 |
| ATP362083 | 36 | 16.6 | 16.6 | 20 | 8 | 3 | 1 | 66 | 112 | 183 |
| ATP361883 | 36 | 16.6 | 18 | 20 | 8 | 3 | 1 | 66 | 112 | 183 |
| ATP3618104 | 36 | 8.5 | 12 | 18 | 10 | 4 | 1 | 71 | 122 | 194 |
| ATP50241210 | 50 | 16.5 | 20 | 24 | 12 | 10 | 1.5 | 138 | 234 | 377 |
| ATP50241212 | 50 | 16.5 | 22 | 24 | 12 | 12 | 1 | 138 | 234 | 377 |
| ATP60271310 | 60 | 20.5 | 24 | 27 | 13 | 10.5 | 1.5 | 224 | 387 | 622 |
| ATP6027134 | 60 | 20.5 | 24 | 27 | 13 | 4 | 1.5 | 224 | 387 | 622 |
| ATP6027304 | 60 | 20.5 | 24 | 27 | 30 | 4 | 1.5 | 224 | 387 | 622 |

Max compression load in Kg deflection in mm.

This information is for guidance only. Customers are recommended to contact us for further technical information on products and applications. We reserve the right to alter specifications or withdraw products without notice.

Ring Elements



Ring Elements offer a versatile and cost effective mounting solution to absorb shock and reduce vibration. They are available in a variety of sizes, rubber compounds, mild and stainless steel metals.

Applications:

- Bump stops for General Industrial Machinery
- Pump & Compressor Feet
- Commercial & Off-Road Vehicles

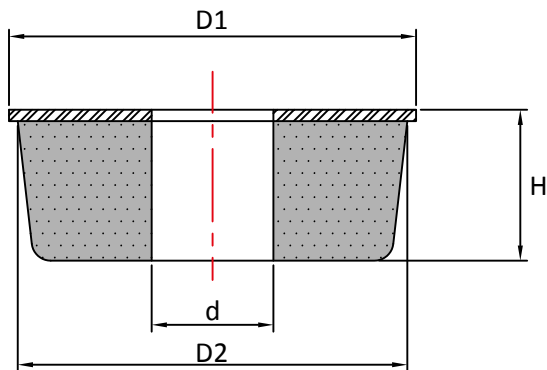

| Part No | D1 | D2 | d | H | Max Load (kg) |
|------------|-----|-----|----|----|---------------|
| 4223TRB18 | 42 | 40 | 18 | 23 | 163.0 |
| 6233TRB21 | 62 | 60 | 21 | 33 | 493.0 |
| 7233TRB21 | 72 | 70 | 21 | 33 | 610.0 |
| 8240TRB25 | 82 | 80 | 25 | 40 | 1319.0 |
| 10254TRB32 | 102 | 100 | 32 | 54 | 1619.0 |
| 12246TRB38 | 122 | 120 | 38 | 46 | 1935.0 |

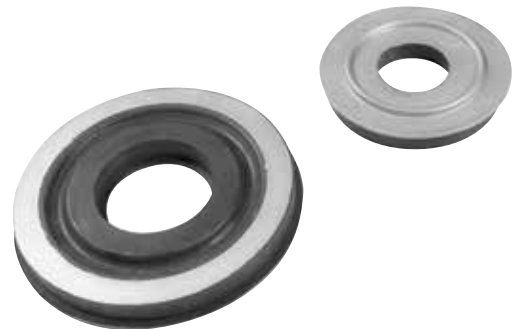
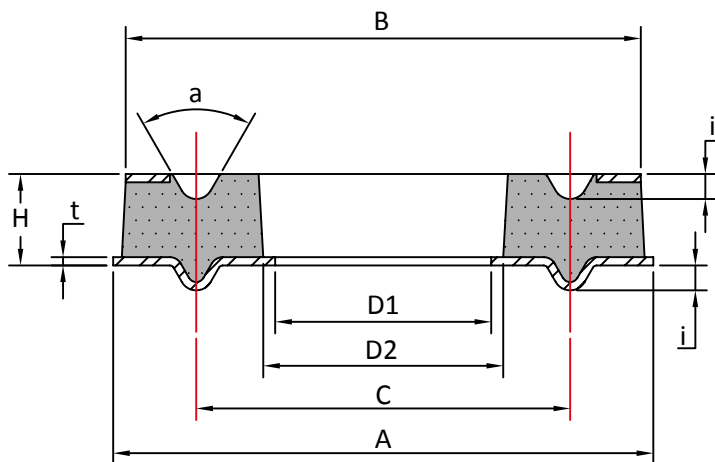

| Part No | A | D1 | B | D2 | C | H | t | i | a° |
|---------|-----|----|-----|----|-----|------|------|-----|----|
| RE6511 | 65 | 26 | 62 | 29 | 46 | 11 | 1 | 2.5 | 60 |
| RE10027 | 100 | 35 | 90 | 40 | 65 | 27.5 | 1.5 | 3.5 | 60 |
| RE11020 | 110 | 30 | 102 | 38 | 76 | 20.8 | 1.75 | 3.5 | 60 |
| RE11025 | 110 | 30 | 102 | 38 | 76 | 25.8 | 1.75 | 3.5 | 60 |
| RE11015 | 110 | 40 | 102 | 44 | 76 | 15.8 | 1.75 | 3.5 | 60 |
| RE15316 | 153 | 55 | 145 | 60 | 102 | 16 | 2 | 5 | 60 |
| RE15330 | 153 | 55 | 145 | 60 | 102 | 30 | 2 | 5 | 60 |

Max compression load in Kg deflection in mm.

This information is for guidance only. Customers are recommended to contact us for further technical information on products and applications. We reserve the right to alter specifications or withdraw products without notice.

Ring Elements

Ring Element Type 1

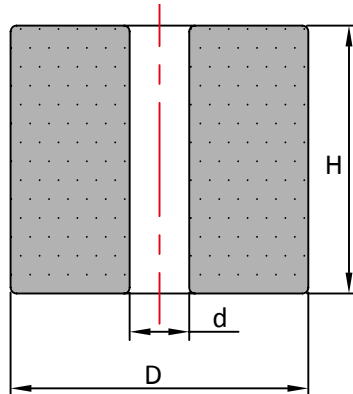

Ring Element Type 2

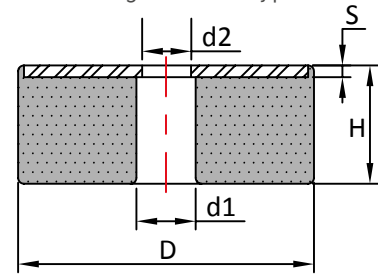

| Part No | D | d | H |
|-----------------|------|------|-----|
| RE1/8.5/3.2-3.5 | 8.5 | 3.2 | 3.5 |
| RE1/13/6.5-12 | 13 | 6.5 | 12 |
| RE1/17.5/9-16 | 17.5 | 9 | 16 |
| RE1/19/13-19 | 19 | 13 | 19 |
| RE1/20/8.5/15 | 20 | 8.5 | 15 |
| RE1/25/8.5-25 | 25 | 8.5 | 25 |
| RE1/25/10.5-25 | 25 | 10.5 | 25 |
| RE1/25/10.5-15 | 25 | 10.5 | 15 |
| RE1/28/10.5-50 | 28 | 10.5 | 50 |
| RE1/28/8-16 | 28 | 8 | 16 |
| RE1/30/16-40 | 30 | 16 | 40 |
| RE1/32/13.5-32 | 32 | 13.5 | 32 |
| RE1/40/9-30 | 40 | 9 | 30 |
| RE1/40/12-25 | 40 | 12 | 25 |
| RE1/40/12-35 | 40 | 12 | 35 |
| RE1/40/12-65 | 40 | 12 | 65 |
| RE1/40/13-30 | 40 | 13 | 30 |
| RE1/40/13.5-32 | 40 | 13.5 | 32 |
| RE1/40/13.5-40 | 40 | 13.5 | 40 |
| RE1/40/13.5-50 | 40 | 13.5 | 50 |
| RE1/40/17-30 | 40 | 17 | 30 |
| RE1/47/20-50 | 47 | 20 | 50 |
| RE1/48/17-100 | 48 | 17 | 100 |
| RE1/50/17-25 | 50 | 17 | 25 |
| RE1/50/17-40 | 50 | 17 | 40 |
| RE1/50/10-45 | 50 | 10 | 45 |
| RE1/50/14-80 | 50 | 14 | 80 |
| RE1/50/17-32 | 50 | 17 | 32 |
| RE1/50/17-50 | 50 | 17 | 50 |
| RE1/50/17-63 | 50 | 17 | 63 |
| RE1/50/17-80 | 50 | 17 | 80 |
| RE1/58/17-100 | 58 | 17 | 100 |
| RE1/50/20-38 | 50 | 20 | 38 |
| RE1/50/24-50 | 50 | 24 | 50 |

| Part No | D | d | H |
|-----------------|-----|------|-----|
| RE1/50/24.8-50 | 50 | 24.8 | 50 |
| RE1/53/32.5-100 | 53 | 32.5 | 100 |
| RE1/60/20-40 | 60 | 20 | 40 |
| RE1/70/40-40 | 70 | 40 | 40 |
| RE1/75/18-40 | 75 | 18 | 40 |
| RE1/80/15-50 | 80 | 15 | 50 |
| RE1/80/20-27 | 80 | 20 | 27 |
| RE1/80/20-40 | 80 | 20 | 40 |
| RE1/80/21-30 | 80 | 21 | 30 |
| RE1/80/25-40 | 80 | 25 | 40 |
| RE1/80/25-82 | 80 | 25 | 82 |
| RE1/80/30-35 | 80 | 30 | 35 |
| RE1/80/40-30 | 80 | 40 | 30 |
| RE1/80/21-100 | 80 | 21 | 100 |
| RE1/90/30-45 | 90 | 30 | 45 |
| RE1/100/21-40 | 100 | 21 | 40 |
| RE1/100/25-40 | 100 | 25 | 40 |
| RE1/100/25-70 | 100 | 25 | 70 |
| RE1/100/26-40 | 100 | 26 | 40 |
| RE1/100/30-35 | 100 | 30 | 35 |
| RE1/100/33-40 | 100 | 33 | 40 |
| RE1/100/33-75 | 100 | 33 | 75 |
| RE1/100/40-70 | 100 | 40 | 70 |
| RE1/100/70-40 | 100 | 70 | 40 |
| RE1/120/25-40 | 120 | 25 | 40 |
| RE1/120/40-40 | 120 | 40 | 40 |
| RE1/120/50-40 | 120 | 50 | 40 |
| RE1/125/35-125 | 125 | 35 | 125 |
| RE1/125/50-125 | 125 | 50 | 125 |
| RE1/150/51-100 | 150 | 51 | 100 |
| RE1/150/45-180 | 150 | 45 | 180 |
| RE1/160/33-160 | 160 | 33 | 160 |
| RE1/200/61-100 | 200 | 61 | 100 |
| RE1/200/33-200 | 200 | 33 | 200 |
| RE1/250/60-200 | 250 | 60 | 200 |

| Part No | D | H | d1 | d2 | S |
|------------|-----|----|----|----|---|
| 3016PRB09 | 30 | 16 | 16 | 9 | 3 |
| 4016PRB09 | 40 | 16 | 16 | 9 | 3 |
| 4020PRB09 | 40 | 20 | 17 | 9 | 3 |
| 5016PRB11 | 50 | 16 | 20 | 11 | 3 |
| 5020PRB11 | 50 | 20 | 22 | 11 | 3 |
| 6020PRB11 | 60 | 20 | 25 | 11 | 4 |
| 7525PRB13 | 75 | 25 | 30 | 13 | 6 |
| 8020PRB13 | 80 | 20 | 32 | 13 | 4 |
| 10025PRB13 | 100 | 25 | 40 | 13 | 6 |
| 10030PRB33 | 100 | 30 | 60 | 33 | 6 |
| 12525PRB17 | 125 | 25 | 50 | 17 | 6 |

Ring Element Type 3

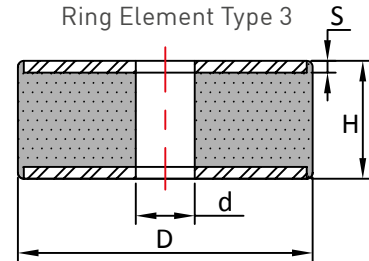

| Part No | D | d | H | S |
|----------------|-----|----|-----|---|
| RE3/15/6-25 | 15 | 6 | 25 | 2 |
| RE3/20/6-25 | 20 | 6 | 25 | 2 |
| RE3/40/13-20 | 40 | 13 | 20 | 3 |
| RE3/40/13-30 | 40 | 13 | 30 | 3 |
| RE3/40/13-40 | 40 | 13 | 40 | 3 |
| RE3/50/17-20 | 50 | 17 | 20 | 3 |
| RE3/50/17-40 | 50 | 17 | 40 | 3 |
| RE3/50/17-50 | 50 | 17 | 50 | 3 |
| RE3/50/21-15 | 50 | 21 | 15 | 3 |
| RE3/50/21-30 | 50 | 21 | 30 | 3 |
| RE3/60/21-50 | 60 | 21 | 50 | 4 |
| RE3/75/25-55 | 75 | 25 | 55 | 3 |
| RE3/80/21-30 | 80 | 21 | 30 | 3 |
| RE3/100/21-40 | 100 | 21 | 40 | 4 |
| RE3/100/31-40 | 100 | 31 | 40 | 4 |
| RE3/100/33-75 | 100 | 33 | 75 | 5 |
| RE3/120/41-40 | 120 | 41 | 40 | 5 |
| RE3/120/51-40 | 120 | 51 | 40 | 5 |
| RE3/150/51-100 | 150 | 51 | 100 | 6 |
| RE3/200/32-100 | 200 | 32 | 100 | 8 |
| RE3/200/61-100 | 200 | 61 | 100 | 8 |

Max compression load in Kg deflection in mm.

This information is for guidance only. Customers are recommended to contact us for further technical information on products and applications.

We reserve the right to alter specifications or withdraw products without notice.



INDUSTRIAL PRODUCTS

Notes





INDUSTRIAL PRODUCTS

Construction, Earth Moving and Agricultural Machinery

| | | | |
|--------------------------------------|----|------------------------------------|-----|
| Hydro Mountings | | Shear Compression Mountings | 96 |
| Hydro Mountings | 78 | Interleaf Mountings | 97 |
| Cone and Cab Mountings | | Bemag Mountings | 98 |
| Cone Mountings | 83 | Hollow Rubber Springs | 99 |
| Flanged Compression Mountings | 90 | Single Convolution | 100 |
| CDM Mountings | 91 | Double Convolution | 101 |
| Multi Directional Mountings | 92 | Triple Convolution and Rectangular | 102 |
| Cab Mountings | 93 | Truck Buffers | 103 |
| SW Mountings | 94 | Tipper Body Pads | 104 |
| | | IOS Bushes | 105 |
| | | Eccentric Bushes | 106 |
| | | Spherical Bushes | 107 |
| | | Flanged Bushes | 108 |



CONSTRUCTION, EARTH MOVING AND AGRICULTURAL MACHINERY

Hydro Mountings

A Unique design offering Superior Performance - Hydro Mountings combine a Rubber Element with a Hydraulic Viscous Damper in a single unit.

PROVIDES OPTIMUM ISOLATION AT NORMAL RUNNING SPEEDS

CONTROLS EXCESSIVE MOVEMENT & SHAKE AT LOW SPEEDS

The design of the rubber element & viscous pot and plunger system results in Excellent Vibration Absorption, whilst ensuring the dampening effect of the fluid only enacts when necessary (i.e. during shock forces, resonance, or when equipment is out of balance).

Hydro Mounts are particularly suited for use on Vehicle Cabs and Variable Speed Engines where the equipment may operate close to the mountings resonant frequency, such as vehicle idle speed. The viscous damper controls high amplitude "Transit movements" or "Resonance Shaking".

The mountings are manufactured with interlocking metal components to provide a failsafe design suitable for mobile applications.

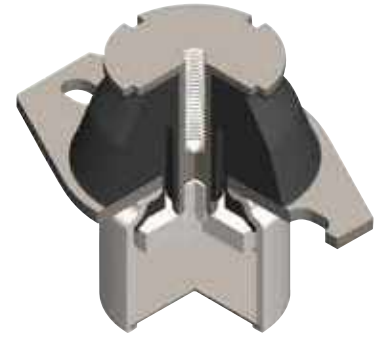

Advantages:

- Excellent Vibration Reduction – upto 95%
- Improve Operator Comfort
- Ideal for Mobile Applications
- Absorbs Transit Shocks
- ROPS & FOPS (subject to approval)

Applications:

- Cabs & Engines
- Off-Highway Vehicles
- Construction & Earthmoving Vehicles
- Agricultural Vehicles
- Variable Speed Engines



Max compression load in Kg deflection in mm.

This information is for guidance only. Customers are recommended to contact us for further technical information on products and applications. We reserve the right to alter specifications or withdraw products without notice.

Hydro Mountings

Definition of a Rubber Spring

A Rubber Spring, such as an Anti Vibration Mounting, is a mechanical device that stores energy and subsequently releases it to absorb shock and vibration. In a highly resilient polymer such as Polyisoprene (Natural Rubber) the amount of stored energy returned into the system can be as high as 97%. By creating installations with high Frequency Ratios, (i.e. the ratio between the disturbing frequency and natural frequency – fd/fn), high levels of vibration isolation can be achieved.

Definition of Damping

Damping is the reduction of amplitude as a result of absorption of energy, where this energy is converted and dissipated as heat. This is an extremely effective way of controlling excessive amplitudes and unwanted movement.

Damping has four common types;

1. Viscous
2. Friction
3. Hysteresis
4. Mass / Tuned

The level of Damping can be measured and quantified in various forms, all of which can be correlated with other known variants;

1. Damping Ratio (ζ) – The ratio between actual damping and critical damping.

$$\zeta = \frac{C}{C_c} = \frac{C}{2\sqrt{k m}}$$

2. Damping Coefficient (**C**) – A measurement of the amount of energy absorbed and is given as Force over Velocity.

$$C = \frac{\sqrt{k m}}{M}$$

3. Loss Angle (α) – The measurement of phase difference between the disturbing input and the response. The bigger the loss angle, the greater the damping.

$$\alpha = \tan^{-1} \left(\frac{F_G}{M} \right)$$

4. Dynamic Magnifier (**M**) – The magnification when the disturbing frequency coincides with the natural frequency of the mounting system (i.e Resonance). The smaller the Dynamic Magnifier the greater the damping.

$$M \text{ (at resonance)} = \frac{1}{\tan^p}$$

5. Rebound Resilience (**RR**) – This is the amount of energy returned from the system. The lower the resilience the greater the damping.

$$RR (\%) = e^{\frac{F}{T}} \times 100$$

Max compression load in Kg deflection in mm.

This information is for guidance only. Customers are recommended to contact us for further technical information on products and applications. We reserve the right to alter specifications or withdraw products without notice.

Dynamic damping characteristics of a Hydro mount

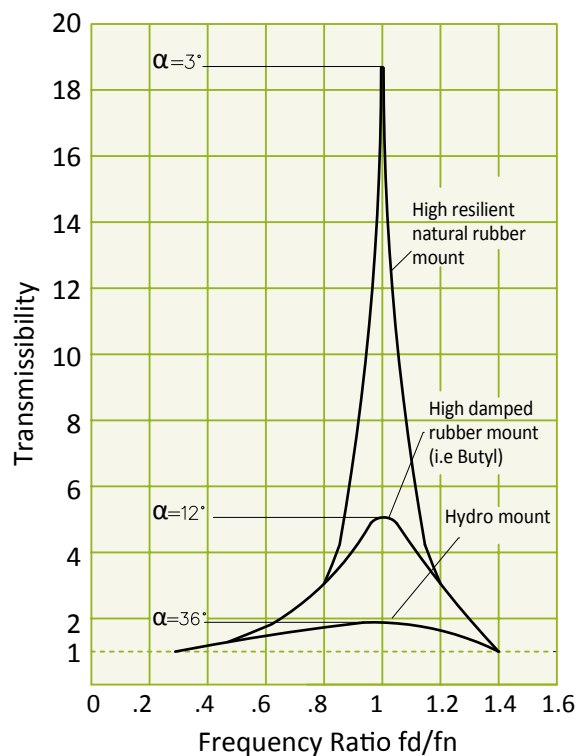
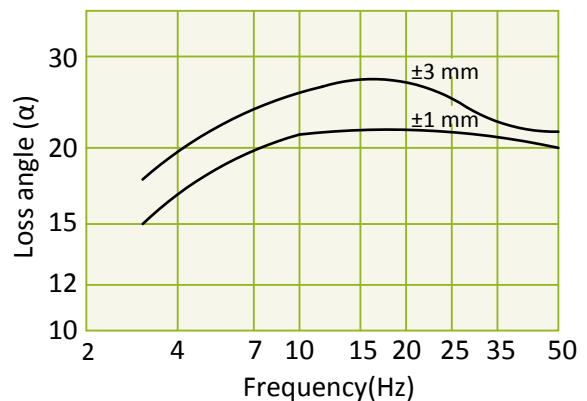

Hydro Mountings

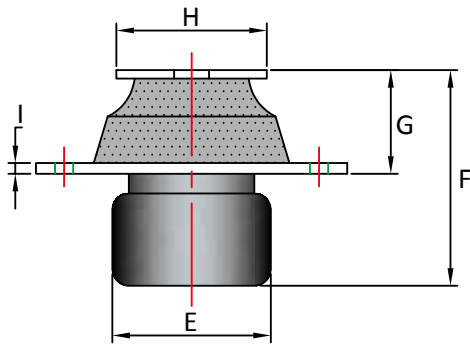

Type A (2 hole)

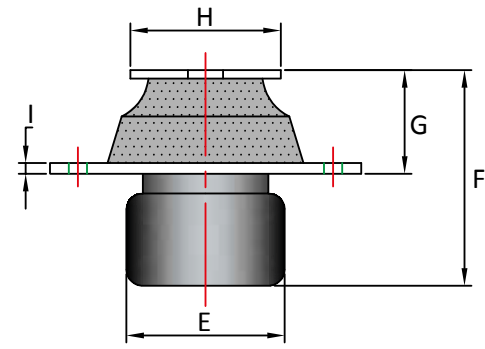

Type B (4 hole)

| Part No | Type | A | B1 | B2 | L1 | L2 | C | E | F | G | H | I | J | K |
|--------------|------|-----|-----|-----|------|------|-----|----|-----|----|----|---|-----|-----|
| HYDVC0.250 | A | 88 | 63 | 73 | - | - | M10 | 45 | 60 | 30 | 30 | 3 | 56 | 8.2 |
| HYDVC1.400 | A | 132 | 99 | 109 | - | - | M10 | 63 | 86 | 36 | 45 | 5 | 90 | 11 |
| HYDVC1.400SQ | B | 105 | 64 | 70 | 79.5 | 82.5 | M10 | 63 | 86 | 36 | 45 | 5 | 91 | 10 |
| HYDVC1.500 | A | 132 | 99 | 109 | - | - | M12 | 63 | 96 | 45 | 60 | 5 | 90 | 11 |
| HYDVC1.500SQ | B | 105 | 64 | 70 | 79.5 | 82.5 | M12 | 63 | 96 | 45 | 60 | 5 | 91 | 10 |
| HYDVC1.550 | A | 132 | 99 | 109 | - | - | M12 | 63 | 96 | 45 | 75 | 5 | 90 | 11 |
| HYDVC1.550SQ | B | 105 | 64 | 70 | 79.5 | 82.5 | M12 | 63 | 96 | 45 | 75 | 5 | 91 | 10 |
| HYDVC3.200 | A | 175 | 130 | 145 | - | - | M20 | 90 | 115 | 53 | 80 | 8 | 108 | 12 |
| HYDVC3.200SQ | B | 130 | 110 | 110 | 110 | 110 | M20 | 90 | 115 | 53 | 80 | 8 | 130 | 12 |



Max compression load in Kg deflection in mm.

This information is for guidance only. Customers are recommended to contact us for further technical information on products and applications. We reserve the right to alter specifications or withdraw products without notice.

CONSTRUCTION, EARTH MOVING AND AGRICULTURAL MACHINERY

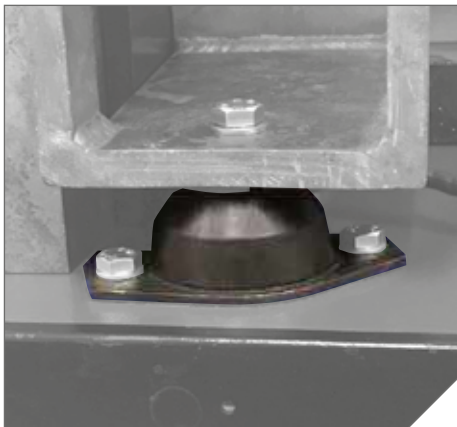
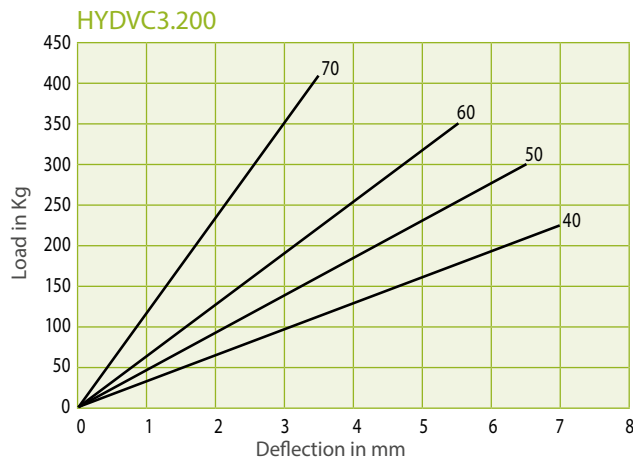
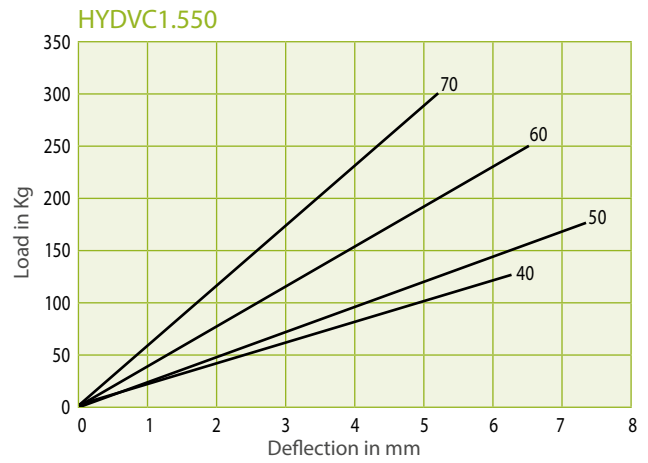
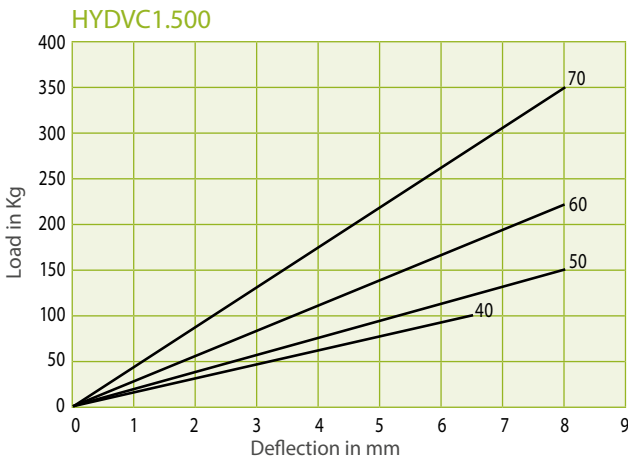
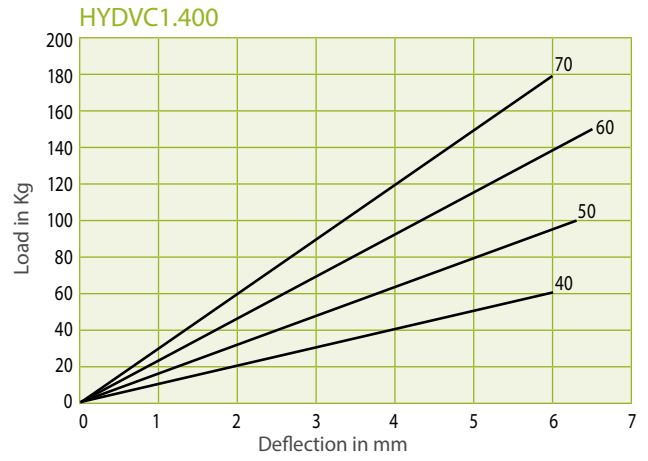
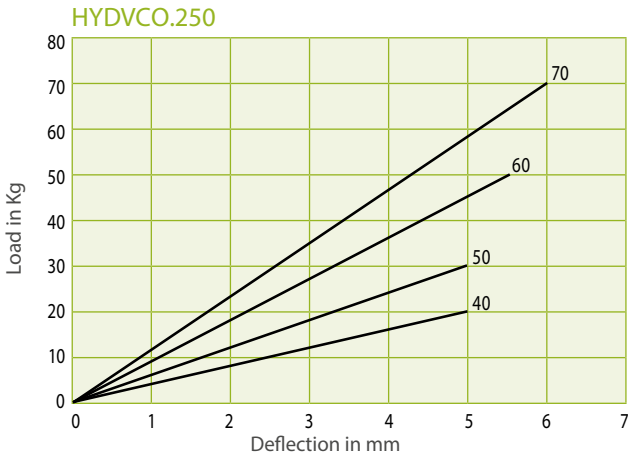

Max compression load in Kg deflection in mm.

This information is for guidance only. Customers are recommended to contact us for further technical information on products and applications. We reserve the right to alter specifications or withdraw products without notice.

Hydro Mountings

HYDVL5.100

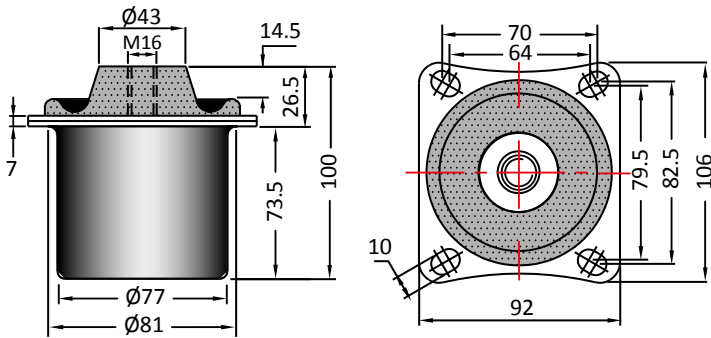

HYDVL5.100

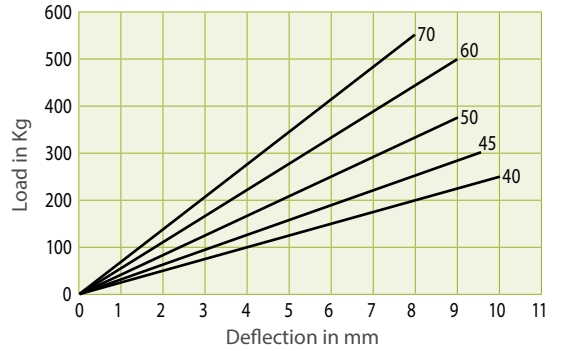

HYDVL5.200

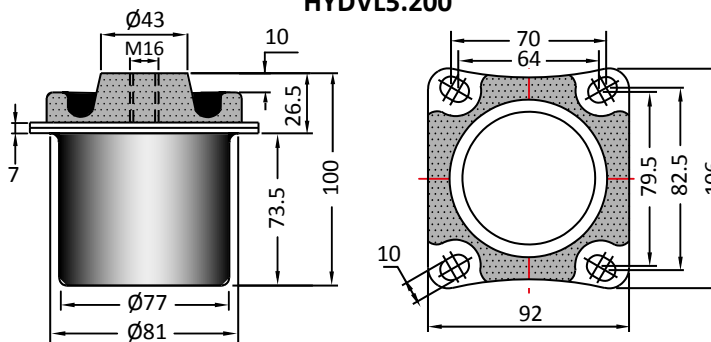

HYDVL5.200

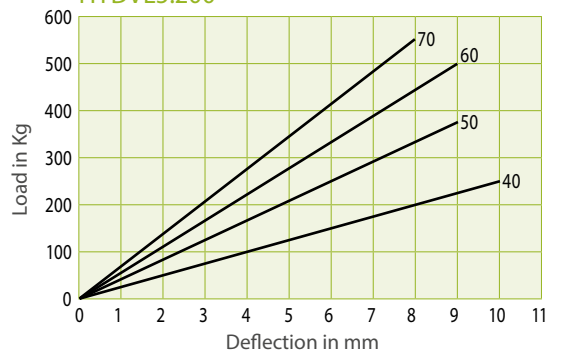

HYDVL7.000

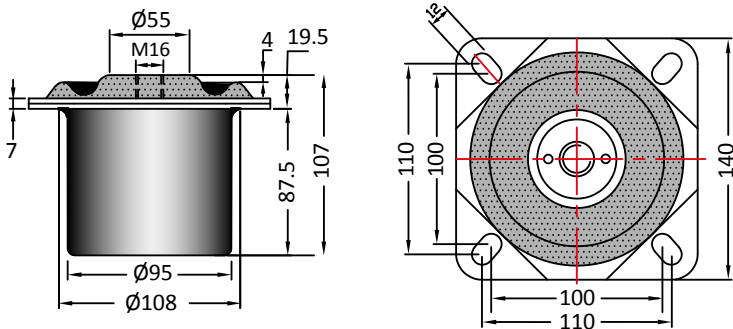

HYDVL7.000

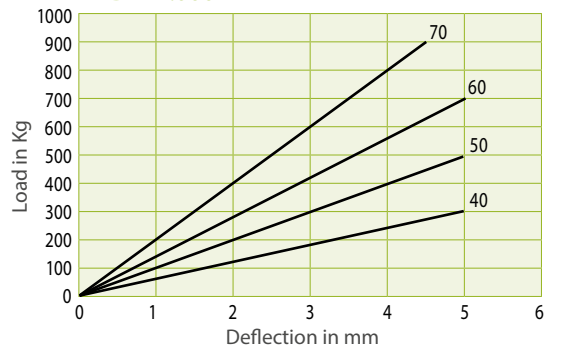

HYDVL7.100

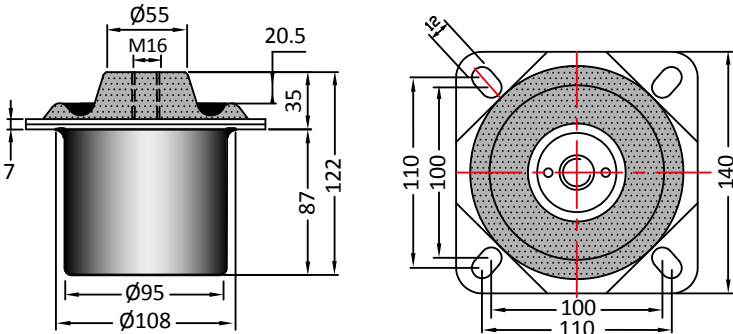

HYDVL7.100

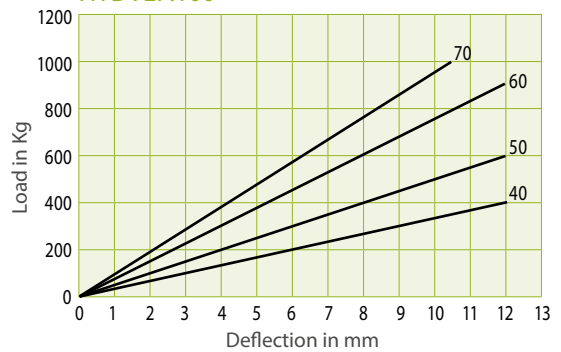

Max compression load in Kg deflection in mm.

This information is for guidance only. Customers are recommended to contact us for further technical information on products and applications.

We reserve the right to alter specifications or withdraw products without notice.

Cone and Cab Mountings

Cone & Cab Mountings are a robust product offering a high horizontal stiffness compared to the vertical stiffness in order to control the movement of Engines, Cabs and Equipment. They are ideal for mobile applications, and are able to accommodate high loads and shock forces whilst offering excellent vibration isolation properties. Cut outs in the rubber section allow for different horizontal to vertical stiffness ratios and the mountings can be supplied with Overload & Rebound washers to provide a failsafe mounting solution. The design of the mountings ensures a low profile installations.

Advantages:

- Failsafe Design
- Ideal for Mobile Applications
- ROPS & FOPS (subject to approval)
- High Shock Load Capacity
- Excellent Vibration Reduction
- Low Profile Installation

Applications:

- Construction Machinery
- Off Road Vehicle Engines
- Vehicle Cabs
- Rail Applications
- Transmission and Gearbox Suspension
- Commercial Vehicles
- Agricultural Vehicles

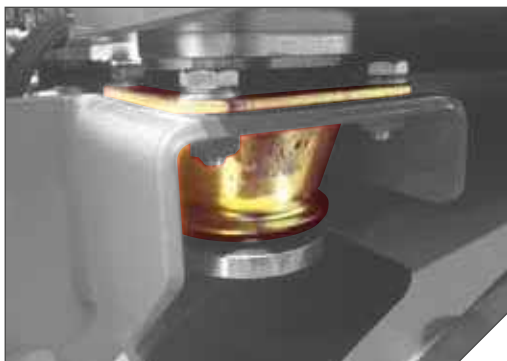

Max compression load in Kg deflection in mm.

This information is for guidance only. Customers are recommended to contact us for further technical information on products and applications. We reserve the right to alter specifications or withdraw products without notice.

Cone Mountings

2 hole

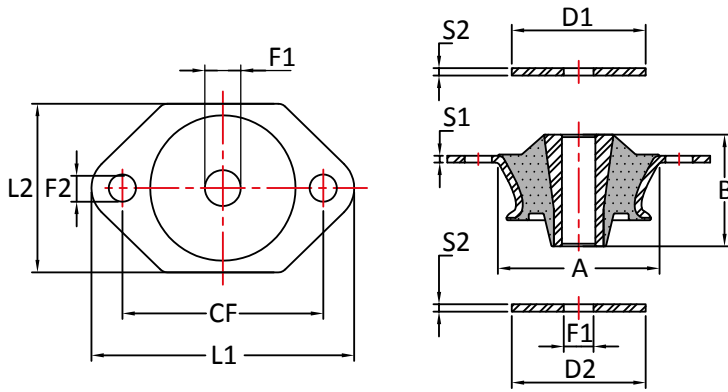

Type A – Solid Rubber

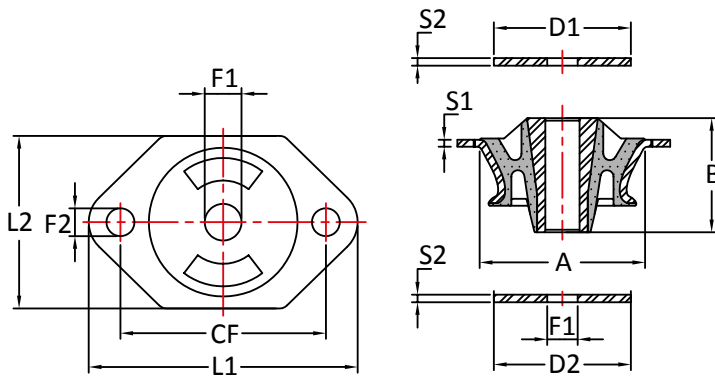
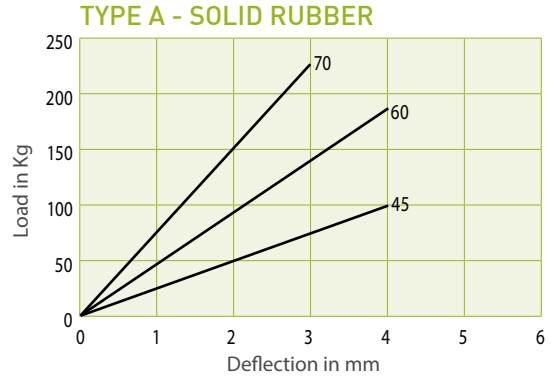

Type B – Slotted Rubber

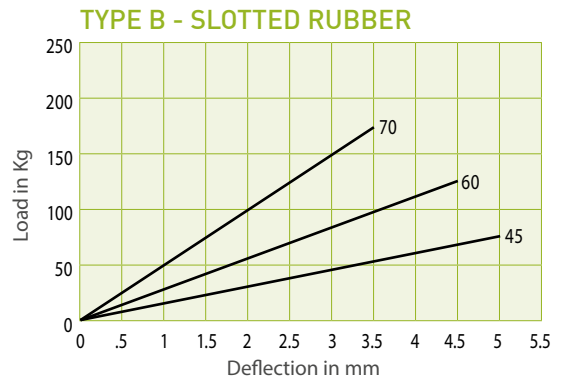

| Part No | Type | A | B | CF | D1 | D2 | F1 | F2 | L1 | L2 | S1 | S2 |
|------------|------|----|----|---------|----|----|----|------|-----|----|-----|-----|
| CM6051/12A | A | 60 | 45 | 78 - 84 | 54 | 54 | 12 | 11.0 | 106 | 68 | 2.5 | 3.0 |
| CM6051/16A | A | 60 | 45 | 78 - 84 | 54 | 54 | 16 | 11.0 | 106 | 68 | 2.5 | 3.0 |
| CM6051/12B | B | 60 | 45 | 78 - 84 | 54 | 54 | 12 | 11.0 | 106 | 68 | 2.5 | 3.0 |
| CM6051/16B | B | 60 | 45 | 78 - 84 | 54 | 54 | 16 | 11 | 106 | 68 | 2.5 | 3.0 |

Max compression load in Kg deflection in mm.

This information is for guidance only. Customers are recommended to contact us for further technical information on products and applications. We reserve the right to alter specifications or withdraw products without notice.



CM379

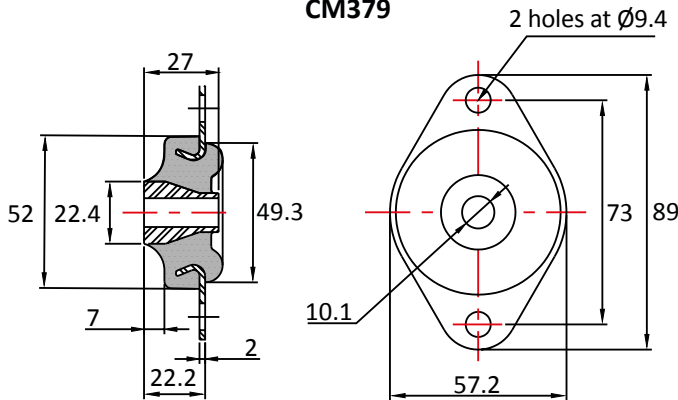

CM379

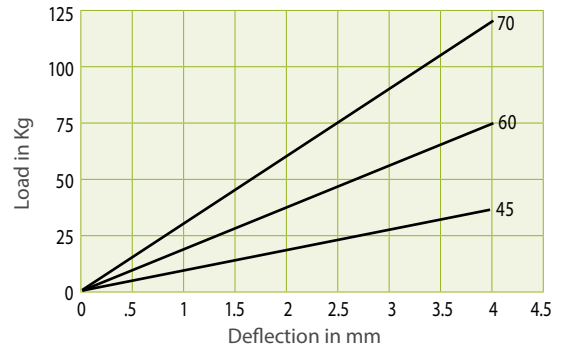

CM1629

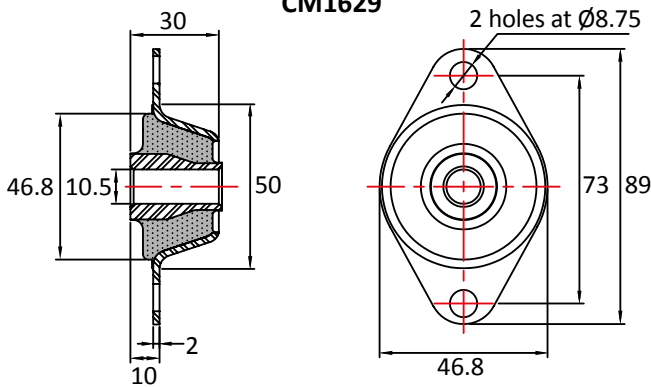

CM1629

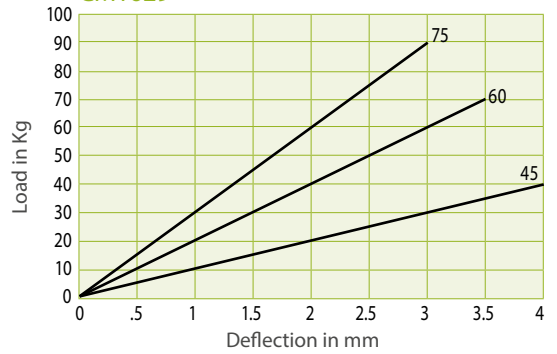

CM472

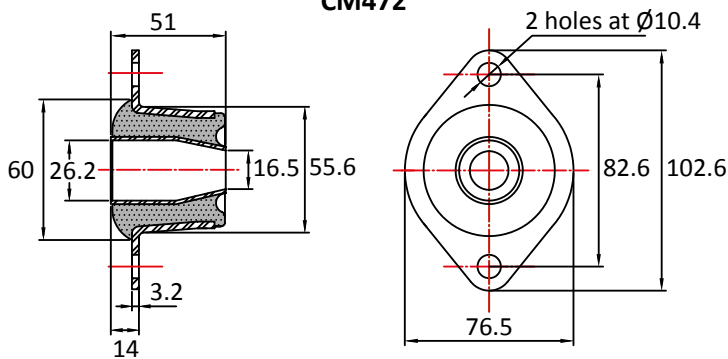

CM472

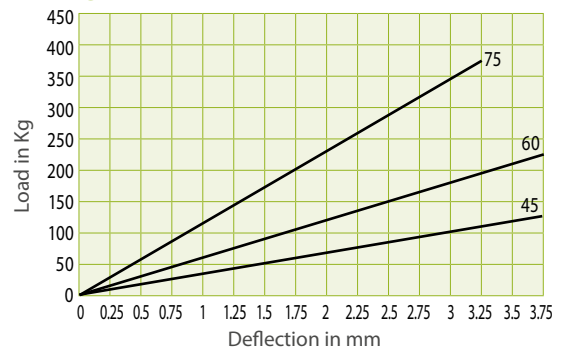

CM30/2

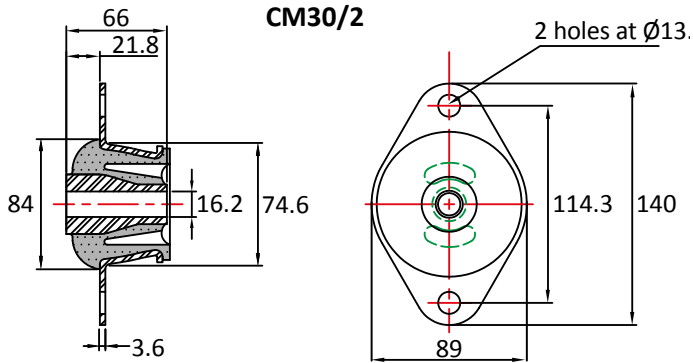

CM30/2

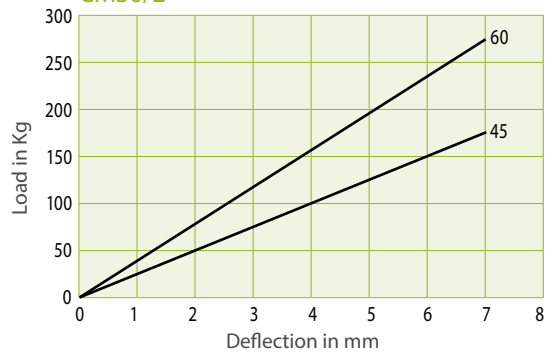

Max compression load in Kg deflection in mm.

This information is for guidance only. Customers are recommended to contact us for further technical information on products and applications.

We reserve the right to alter specifications or withdraw products without notice.



CM482

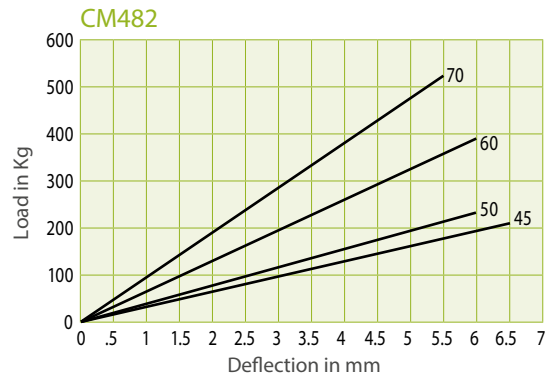
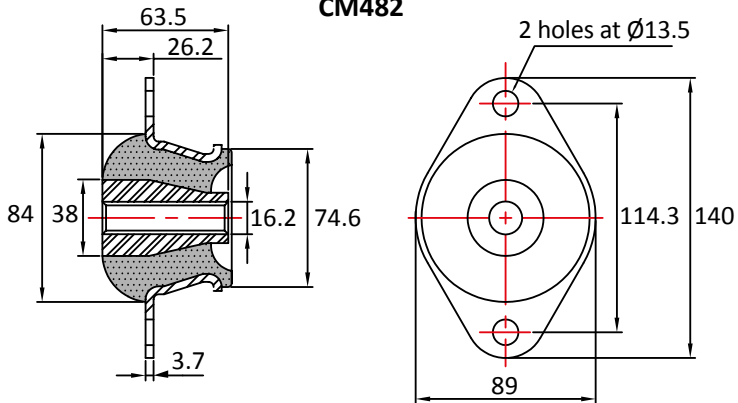

CM285

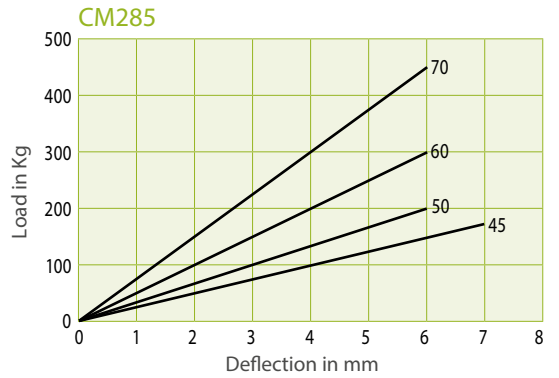
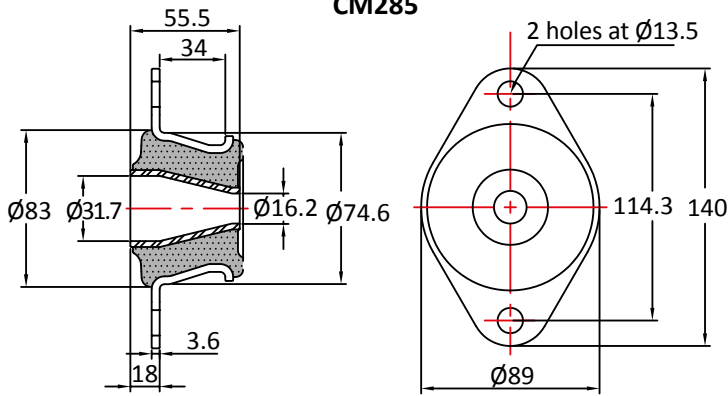

CM276X

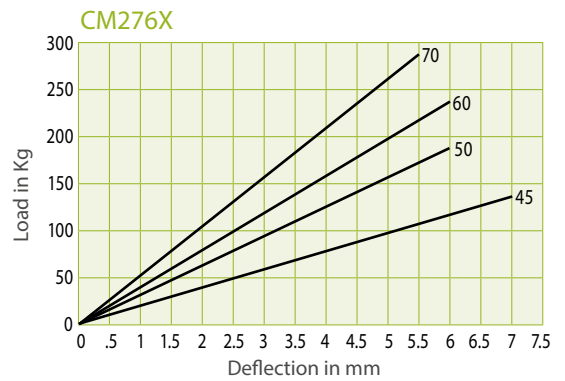
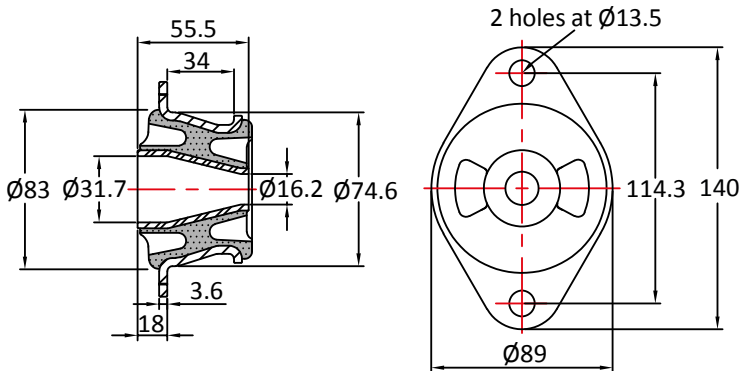

CM310Y

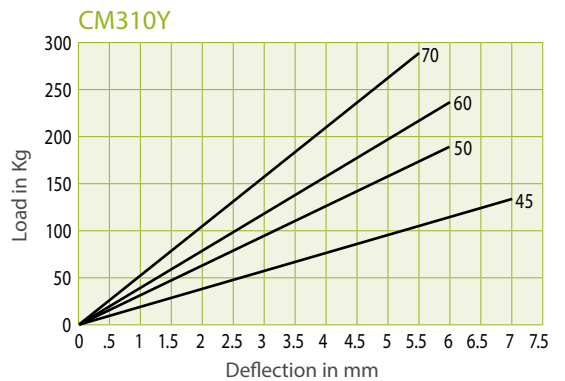
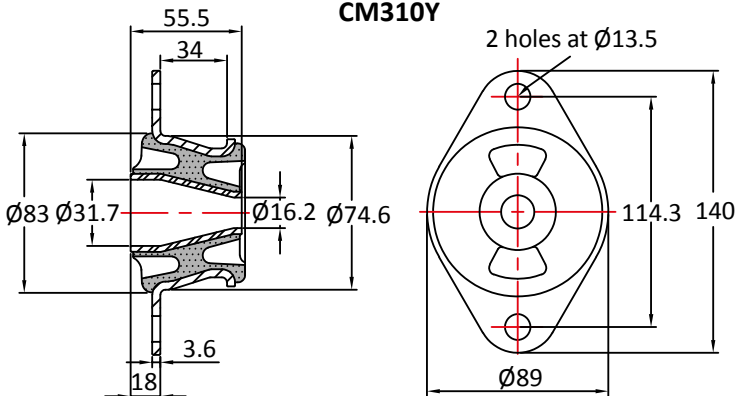

Max compression load in Kg deflection in mm.

This information is for guidance only. Customers are recommended to contact us for further technical information on products and applications.

We reserve the right to alter specifications or withdraw products without notice.

Cone Mountings

4 hole

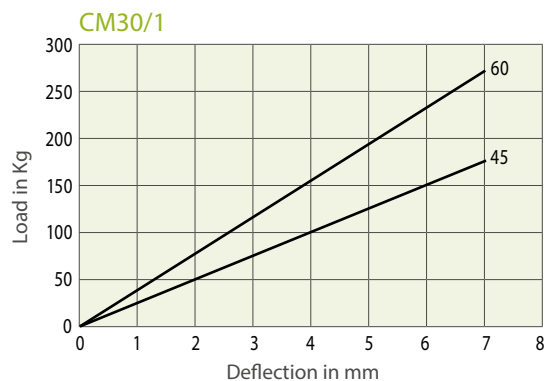
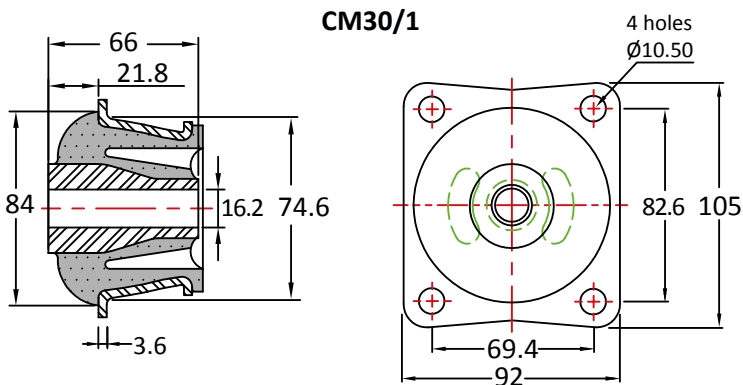
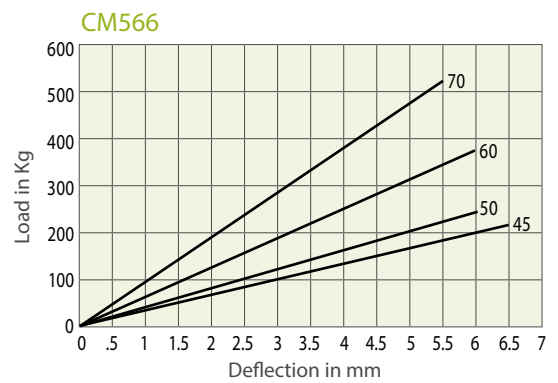
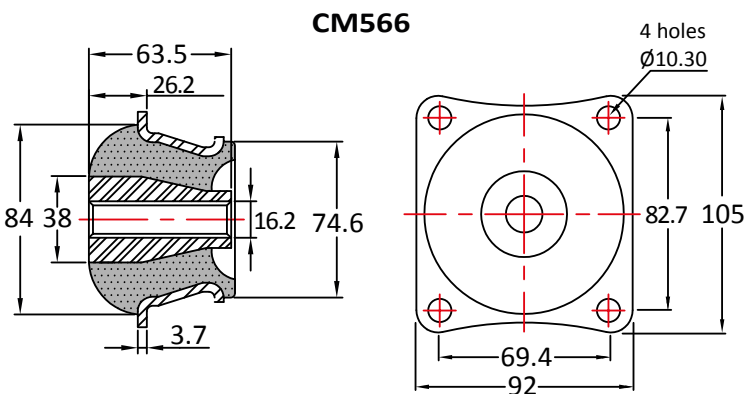
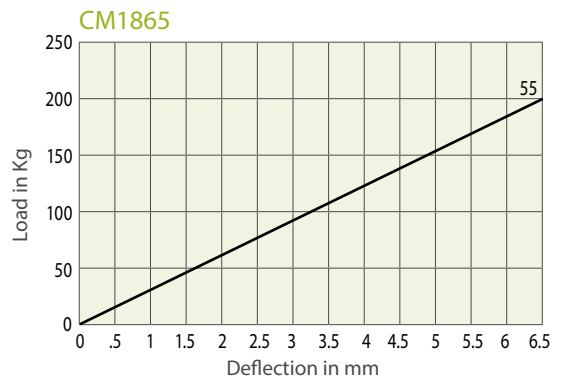
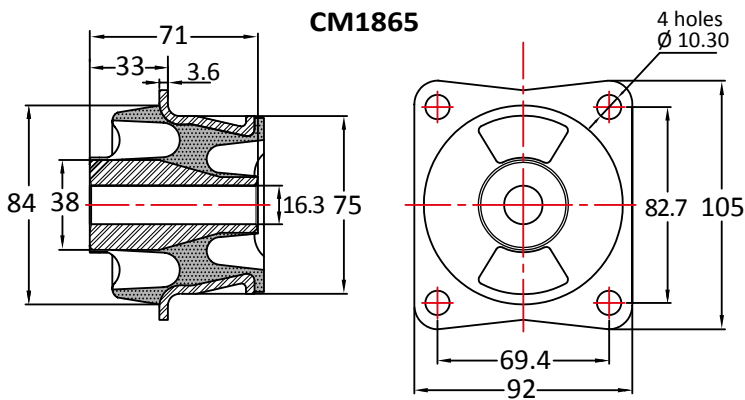
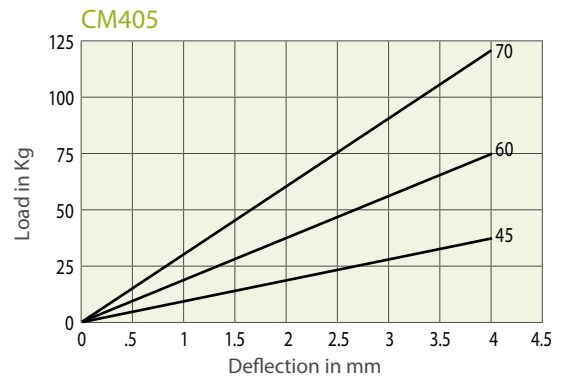
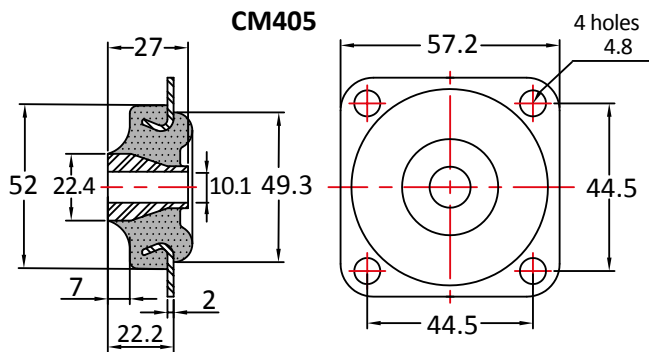

Max compression load in Kg deflection in mm.

This information is for guidance only. Customers are recommended to contact us for further technical information on products and applications.

We reserve the right to alter specifications or withdraw products without notice.



CM341

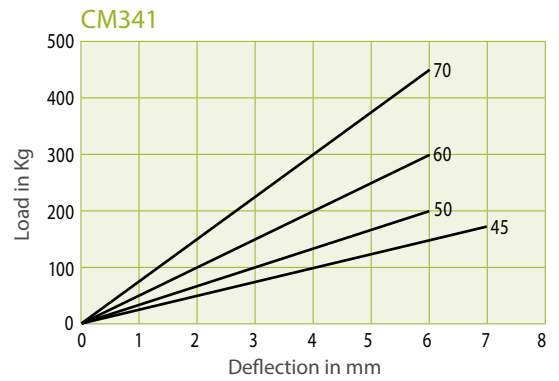
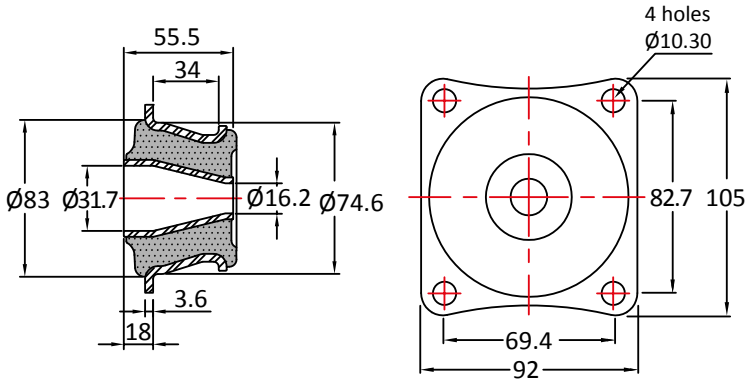

CM277X

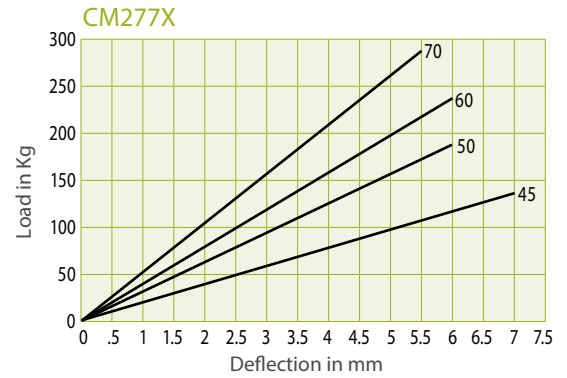
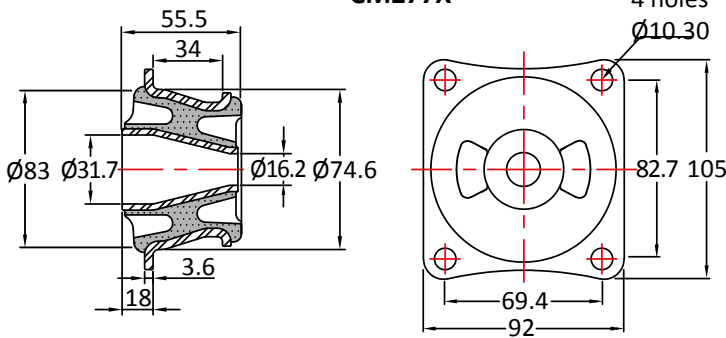

CM311Y

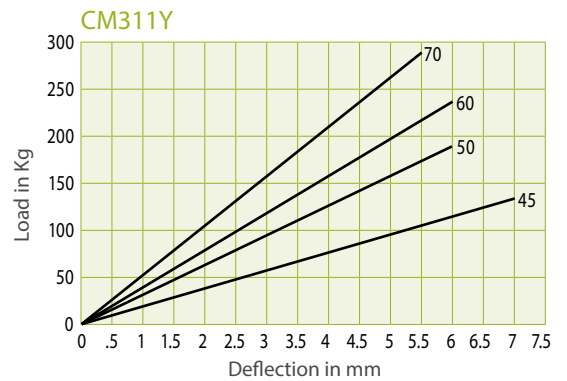
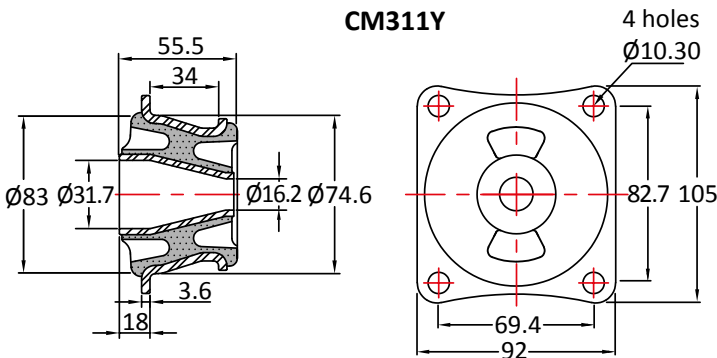

Max compression load in Kg deflection in mm.

This information is for guidance only. Customers are recommended to contact us for further technical information on products and applications.

We reserve the right to alter specifications or withdraw products without notice.

Heavy Duty Mountings



CM225

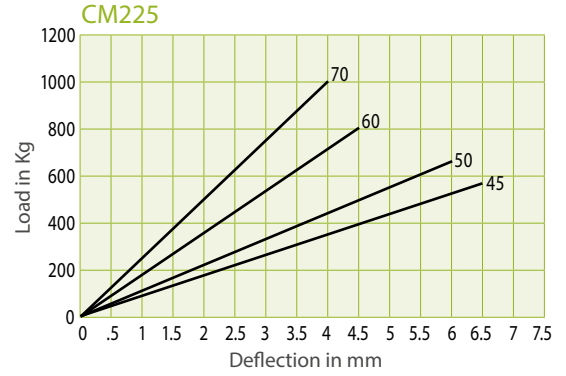
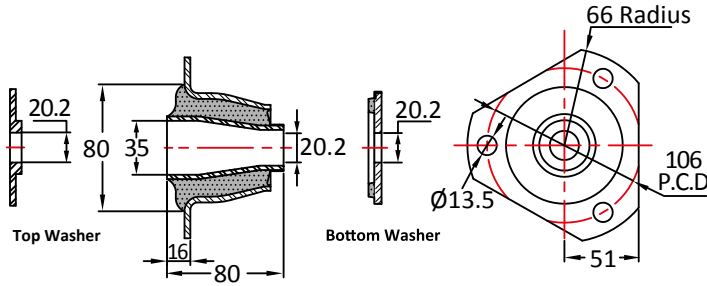

CM391

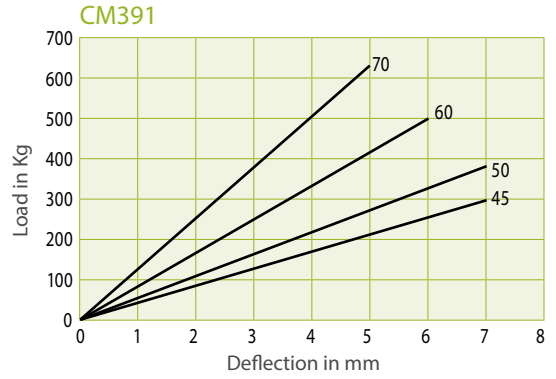
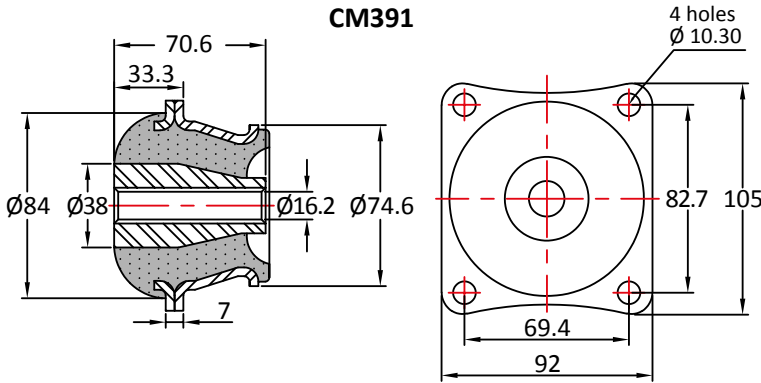

CM146

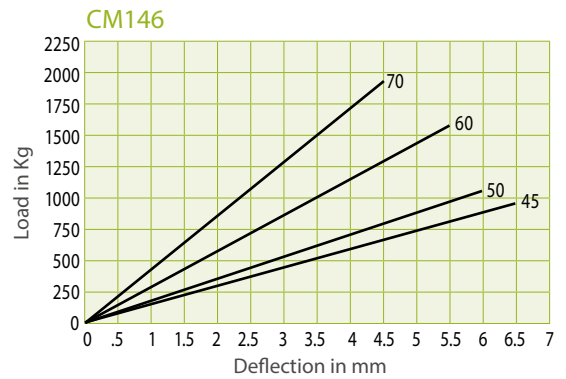
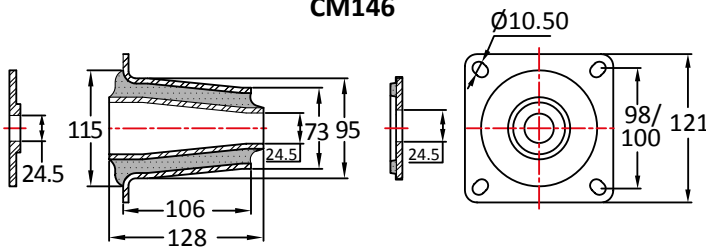

CM1550

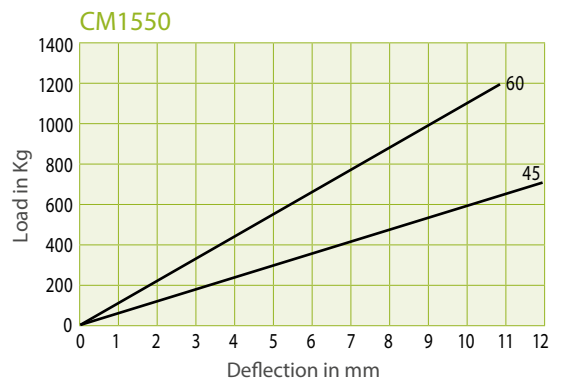
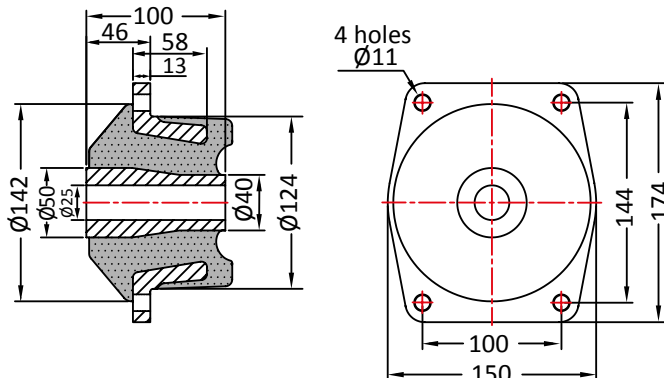

Max compression load in Kg deflection in mm.

This information is for guidance only. Customers are recommended to contact us for further technical information on products and applications.

We reserve the right to alter specifications or withdraw products without notice.

Flanged Compression Mountings



Flanged Compression Mounting are a Low Profile design, ideal for Shock and Vibration absorption. Using Top and Bottom washers provides a fail-safe design, suitable for mobile applications.

Applications:

- Commercial Vehicle
- HVAC
- Radiators
- Pumps
- Compressors

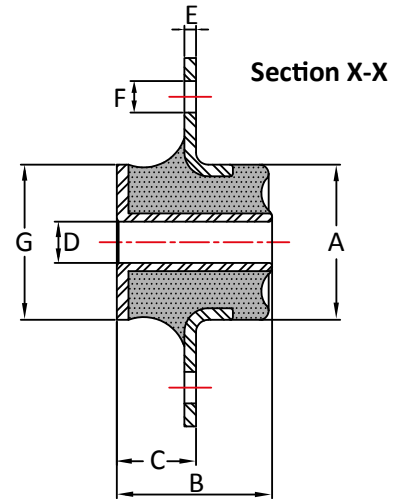
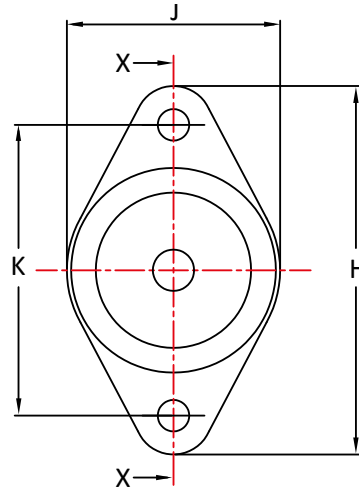

| Part No | A | B | C | D | E | F | G | H | J | K |
|---------|------|------|------|------|-----|------|------|-------|------|------|
| CM507 | 50.8 | 44.4 | 25.1 | 11.7 | 3.2 | 10.3 | 47.8 | 114.3 | 63.5 | 89.9 |
| CM508 | 50.8 | 50.8 | 25.9 | 13.5 | 3.8 | 10.3 | 50.8 | 120.6 | 69.8 | 95.2 |

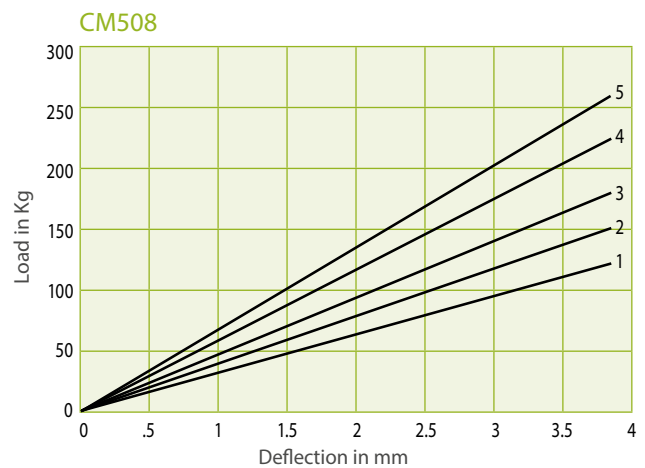
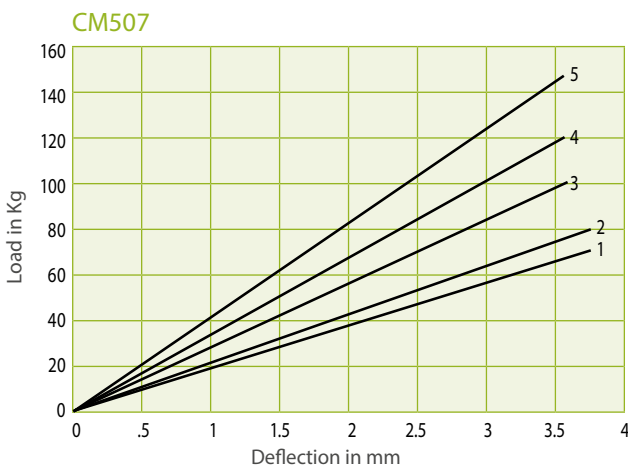

Max compression load in Kg deflection in mm.

This information is for guidance only. Customers are recommended to contact us for further technical information on products and applications. We reserve the right to alter specifications or withdraw products without notice.

CDM Mountings



CDM Mountings are used in pairs, providing a simple single bolt installation. They are able to withstand high dynamic shock loads, particularly when being used on Off-Road Vehicles. The outer body incorporates a steel cup to limit vertical movement and reduce rubber stress, normally caused by bump & shock conditions.

Advantages:

- Simple Single Bolt Installation
- Ideal for Shock & Bump Conditions
- Integral Overload Metal Cup
- Excellent Vibration Reduction

Applications:

- Off-Highway Vehicles
- Construction Vehicles
- Cabs & Engines

Typical Installation

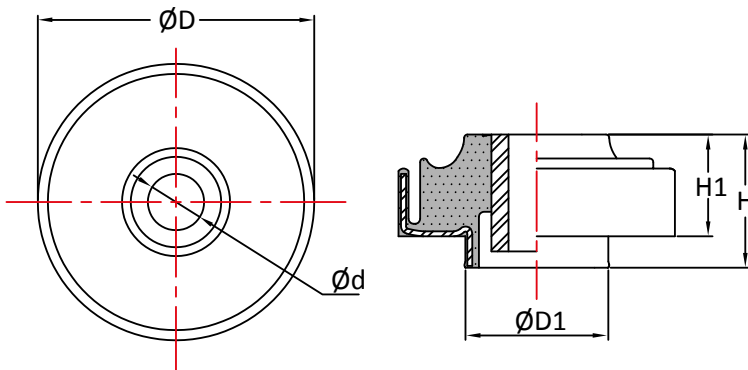
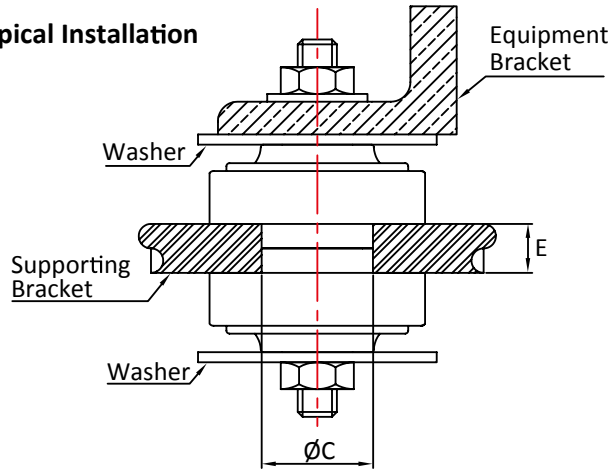

| Part No | d | D | D1 | H | H1 | C | E | Bolt Size | Max. Bolt Torque N/m | Max Load (kg) |
|-----------|------|-----|------|------|------|-------------|-------|------------|----------------------|---------------|
| CDM66-45 | 18.8 | 66 | 39.8 | 38 | 29.5 | 40.0-40.3 | 19/20 | M16 | 240 | 70 |
| CDM66-55 | 18.8 | 66 | 39.8 | 38 | 29.5 | 40.0-40.3 | 19/20 | M16 | 240 | 120 |
| CDM66-65 | 18.8 | 66 | 39.8 | 38 | 29.5 | 40.0-40.3 | 19/20 | M16 | 240 | 170 |
| CDM80-45 | 16.2 | 80 | 37.8 | 41.5 | 32 | 37.9-38.2 | 19/20 | M16 | 240 | 90 |
| CDM80-55 | 16.2 | 80 | 37.8 | 41.5 | 32 | 37.9-38.2 | 19/20 | M16 | 240 | 140 |
| CDM80-65 | 16.2 | 80 | 37.8 | 41.5 | 32 | 37.9-38.2 | 19/20 | M16 | 240 | 200 |
| CDM110-45 | 22.5 | 110 | 56.9 | 51.5 | 39 | 57.2-57.5 | 25 | M20 or M22 | 502/685 | 230 |
| CDM110-55 | 22.5 | 110 | 56.9 | 51.5 | 39 | 57.2-57.5 | 25 | M20 or M22 | 502/685 | 360 |
| CDM110-65 | 22.5 | 110 | 56.9 | 51.5 | 39 | 57.2-57.5 | 25 | M20 or M22 | 502/685 | 510 |
| CDM130-45 | 30.2 | 128 | 69.2 | 58.5 | 43 | 70.75-71.25 | 40 | M30 | 750 | 230 |
| CDM130-55 | 30.2 | 128 | 69.2 | 58.5 | 43 | 70.75-71.25 | 40 | M30 | 750 | 500 |
| CDM130-65 | 30.2 | 128 | 69.2 | 58.5 | 43 | 70.75-71.25 | 40 | M30 | 750 | 600 |

Max compression load in Kg deflection in mm.

This information is for guidance only. Customers are recommended to contact us for further technical information on products and applications. We reserve the right to alter specifications or withdraw products without notice.

Multi Directional Mountings



Multi Directional mountings are used to accommodate forces in both the upwards & downwards direction (i.e. positive and negative forces), and are ideal for applications such as Gearbox mountings where the torque applied during forward and reverse situations needs to be accommodated. Mountings should be used with Top & Bottom overload washers to provide a failsafe mounting arrangement.

Advantages:

- Multi Directional Isolation
- Heavy Duty, Robust Design
- Ideal for Mobile Applications
- ROPS & FOPS (subject to approval)

Applications:

- Vehicle Cabs
- Gearbox and Transmission Mountings
- Military & MOD
- Construction & Earthmoving

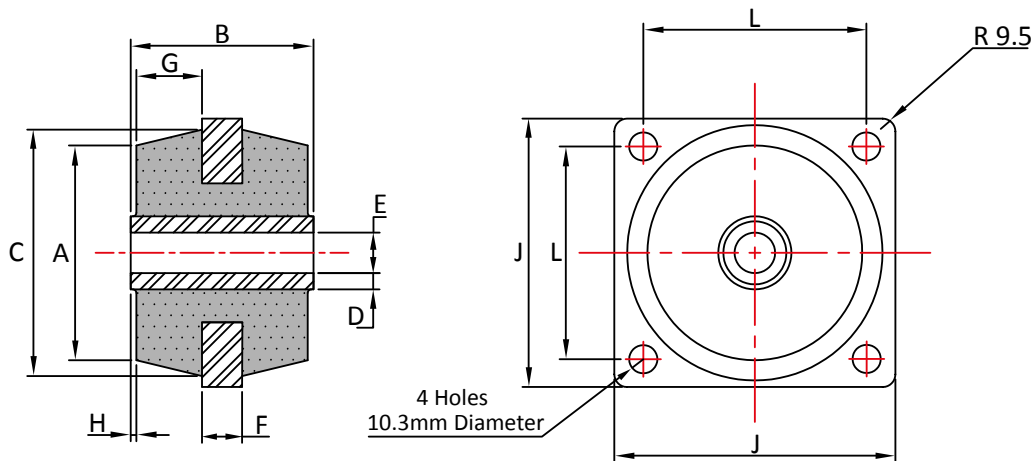

| Part No | A | B | C | D | E | F | G | H | J | L | Max Load (kg) | | | Deflection |
|---------|----|----|----|---|----|----|------|-----|----|----|---------------|---------|---------|------------|
| | | | | | | | | | | | 45 SH A | 60 SH A | 70 SH A | mm |
| CM890 | 69 | 54 | 79 | 5 | 16 | 12 | 19.7 | 1.4 | 89 | 70 | 380 | 735 | 1080 | 5 |

Max compression load in Kg deflection in mm.

This information is for guidance only. Customers are recommended to contact us for further technical information on products and applications. We reserve the right to alter specifications or withdraw products without notice.

Cab Mountings



Cab Mountings provide a simple, single bolt, method of installation. The unique rubber profile design provides a High Level of ride comfort on Vehicle Cabs, and also control of movement under shock and bump. The use of Overload & Rebound washers provide a failsafe solution.

Advantages:

- Simple, Single Bolt Installation
- Ideal for Mobile Applications
- Control Movement on rough Terrain
- Low Stiffness for high ride comfort

Applications:

- Construction Equipment
- Off Road Vehicles
- Tractors
- Material Handling

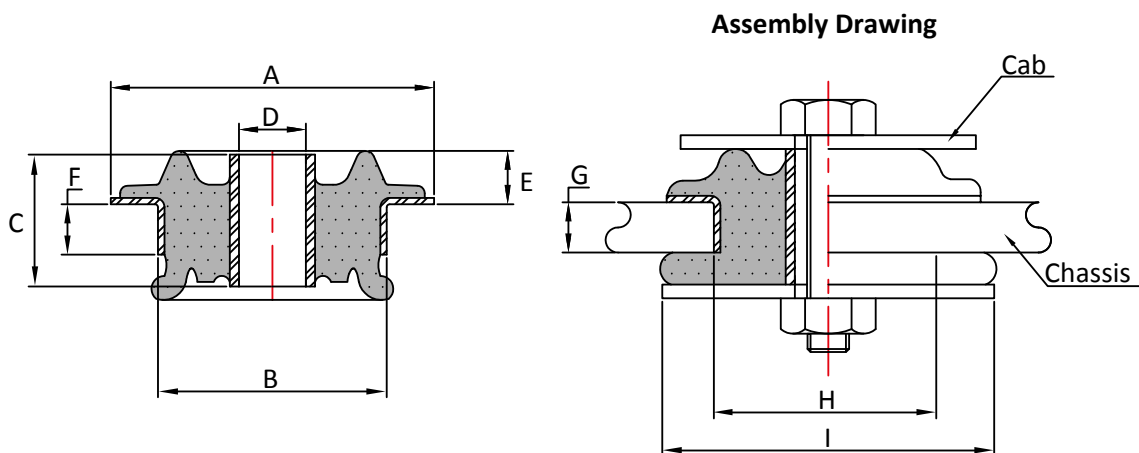

| Part No | A | B | C | D | E | F | G | H Min | H Max | I Min | 45 Shore A | 60 Shore A |
|----------|-----|----|----|------|----|----|----|-------|-------|-------|------------|------------|
| | | | | | | | | | | | Max Kg | Max Kg |
| CB1650/1 | 105 | 75 | 46 | 16.2 | 22 | 17 | 20 | 75.25 | 75.75 | 105 | 300 | 500 |
| CB1650 | 105 | 75 | 46 | 21 | 22 | 17 | 20 | 75.25 | 75.75 | 105 | 300 | 500 |
| CB1814 | 120 | 89 | 47 | 25 | 21 | 23 | 25 | 89.25 | 89.75 | 120 | 428 | 713 |

Max compression load in Kg deflection in mm.

This information is for guidance only. Customers are recommended to contact us for further technical information on products and applications. We reserve the right to alter specifications or withdraw products without notice.

SW Mountings



SW mountings are ideal for Heavy Duty Applications, commonly used in the Mining, Quarrying and Construction Industries.

The mountings consist of a High Dynamic Rubber Compound sandwiched between multiple steel interleaf plates. This design allows the mountings to withstand large compressive forces with minimum deformation, whilst providing a relatively low stiffness in the shear direction.

The combination of Low Height, High Vertical Stiffness and Low Shear Stiffness provides a universal, high performance mounting with uses in many heavy duty engineering applications.

Advantages:

- High Compressive Stiffness
- Low Shear Stiffness
- Low Height
- High Dynamic Rubber Compound

Applications:

- Vibratory Screens & Graders
- Crushing Equipment
- Hoppers & Feeders
- Mining & Quarry Equipment
- Construction Machines

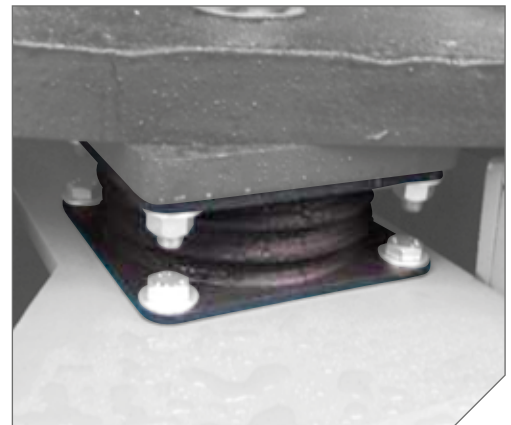
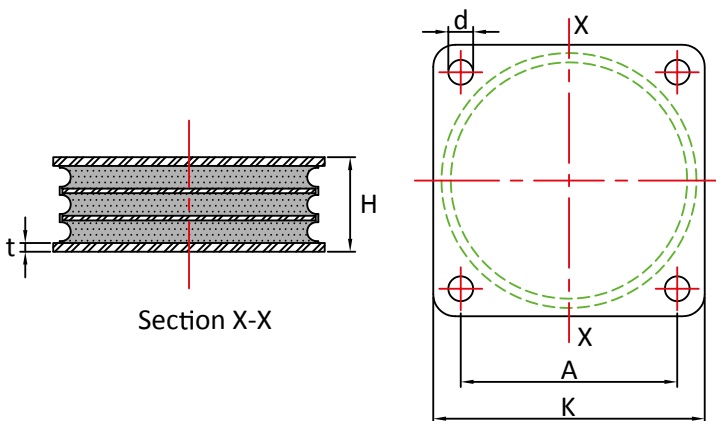

| Part No | A | K | H | d | t | Max Compression Load (Kg) | |
|---------|-----|-----|-----|------|----|---------------------------|----------|
| | | | | | | 40 Shore | 60 Shore |
| SW125 | 118 | 148 | 52 | 13.5 | 5 | 2250 | 4500 |
| SW150 | 136 | 166 | 63 | 13.5 | 6 | 3750 | 7500 |
| SW200 | 184 | 220 | 82 | 17 | 8 | 6000 | 12000 |
| SW300 | 270 | 310 | 120 | 22 | 10 | 15000 | 30000 |

Max compression load in Kg deflection in mm.

This information is for guidance only. Customers are recommended to contact us for further technical information on products and applications. We reserve the right to alter specifications or withdraw products without notice.

SW Mountings

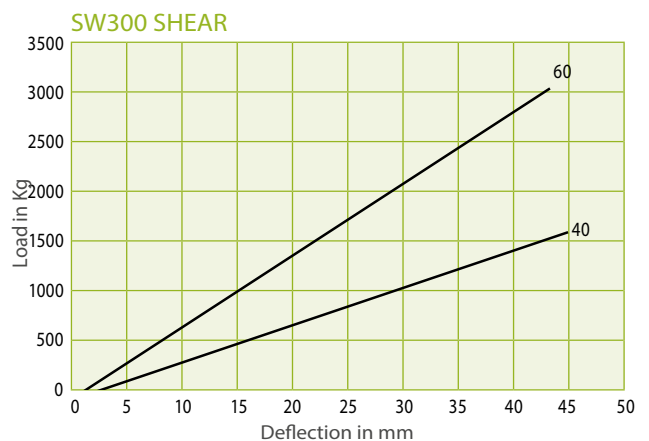
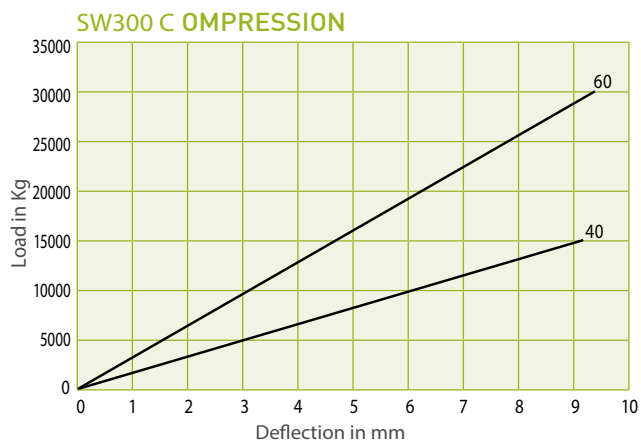
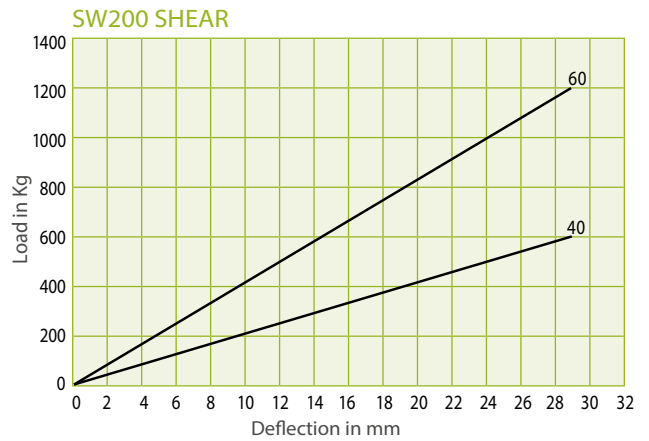
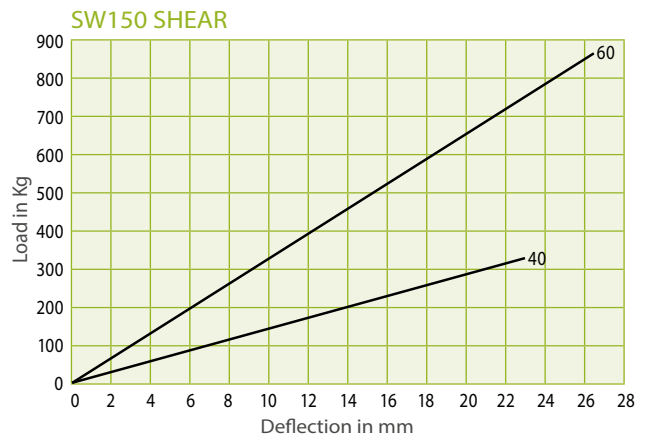
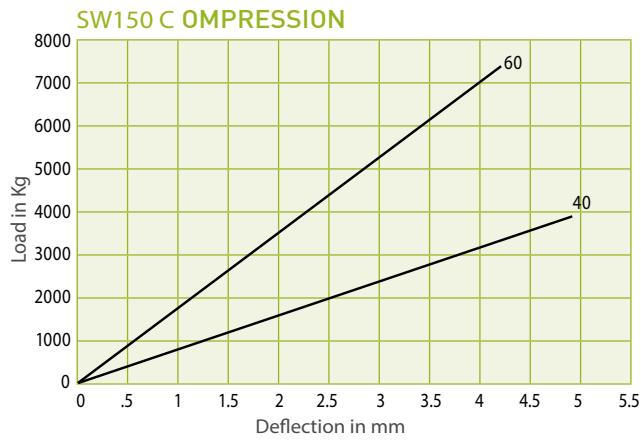
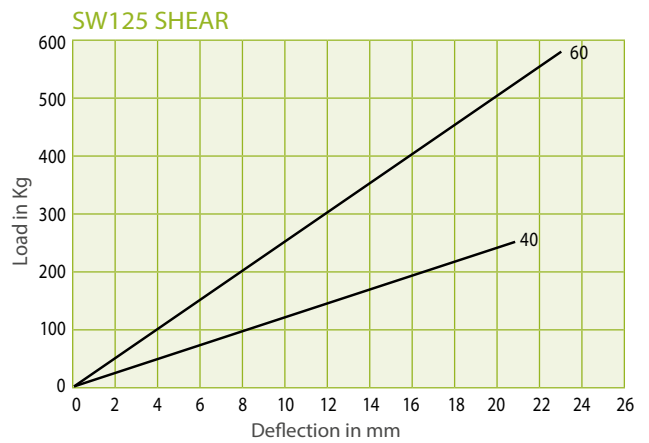
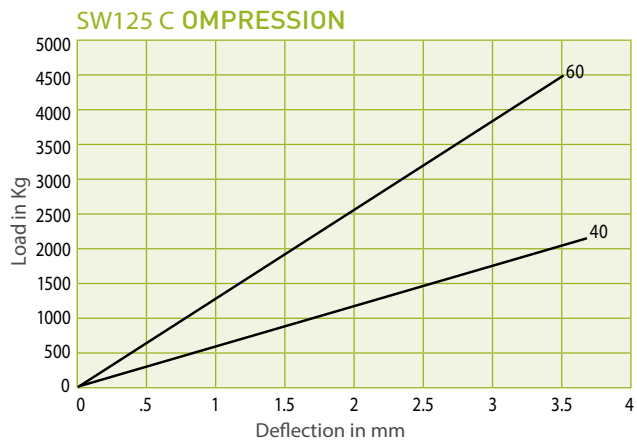

Max compression load in Kg deflection in mm.
 This information is for guidance only. Customers are recommended to contact us for further technical information on products and applications.
 We reserve the right to alter specifications or withdraw products without notice.

Shear Compression Mountings



Shear Compression Mountings are manufactured from high quality natural rubber and are designed to allow large amounts of horizontal and lateral movement. They are typically used in the Construction Industry, particularly on Compaction Equipment. The high grade rubber formulation ensures extended service life under continuous high levels of mechanically induced vibration.

Advantages:

- High Fatigue Rubber – Extended Service Life
- Excellent Vibration Isolation
- Allows High Levels of Movement
- Prevents Wear & Damage to Machine

Applications:

- Vibratory Compaction Equipment
- Plant and Construction Equipment
- Vibrating Screens
- Industrial Machinery

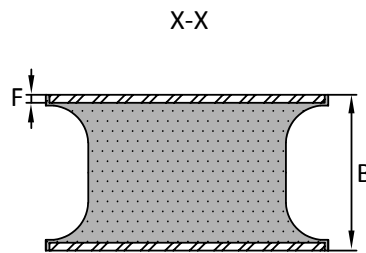
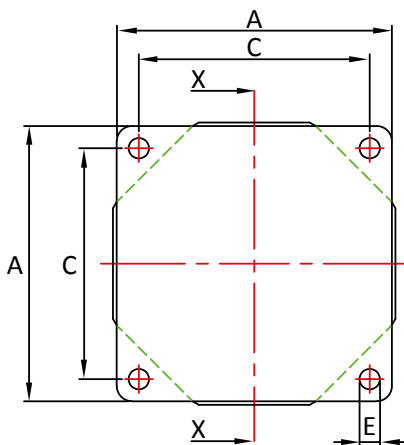

| Part No | A | B | C | E | F |
|-----------|-----|-------|-------|------|-----|
| SCM719649 | 219 | 99.8 | 190 | 13.2 | 4.8 |
| SCM719749 | 174 | 98.5 | 146 | 13.2 | 5.2 |
| SCM719849 | 234 | 139.5 | 190.5 | 19.7 | 6.2 |
| SCM10063 | 100 | 63.5 | 76.2 | 10.5 | 5 |
| SCM345215 | 110 | 61 | 85 | 11 | 3.6 |
| SCM160100 | 160 | 100 | 135 | 13 | 5 |

Max compression load in Kg deflection in mm.

This information is for guidance only. Customers are recommended to contact us for further technical information on products and applications. We reserve the right to alter specifications or withdraw products without notice.

Interleaf Mountings

Interleaf Mountings are produced with an integrally bonded interleaf metal to increase the compression load capacity of the mounting, and are ideal where large compressive forces need to be accommodated whilst giving relatively small amounts of deflection on the product and also retaining their low stiffness in the shear direction. The mountings are also available without interleaf metals.

Advantages:

- Accommodate High Compression Forces
- High Quality Rubber Formulation – Extended Life
- Easy to Install

Applications:

- Vibratory Rollers
- Sieves & Grading Equipment
- Construction Equipment
- Industrial Machinery

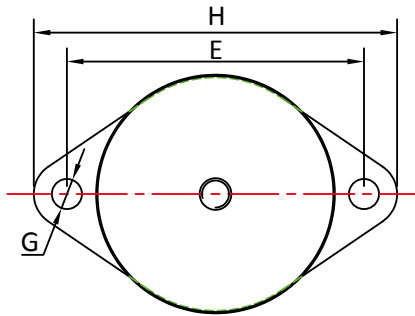
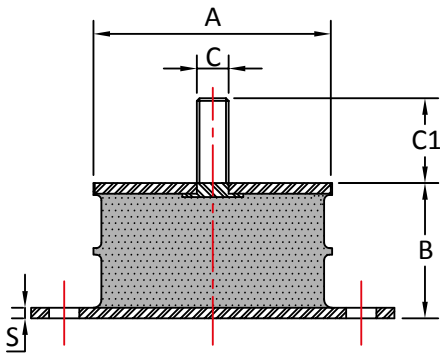

| Part No | A | B | C | C1 | E | G | H | S | 45° Shore | | 60° Shore | |
|----------|----|------|-----|------|-----|----|-----|---|-----------|-----------|-----------|-----------|
| | | | | | | | | | Load (Kg) | Def. (mm) | Load (Kg) | Def. (mm) |
| FCM1536* | 89 | 50.8 | M12 | 32.5 | 112 | 11 | 137 | 4 | 250 | 5 | 500 | 5 |

*Without Metal Interleaf

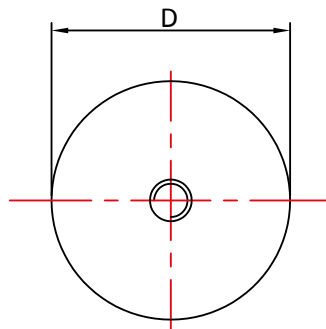
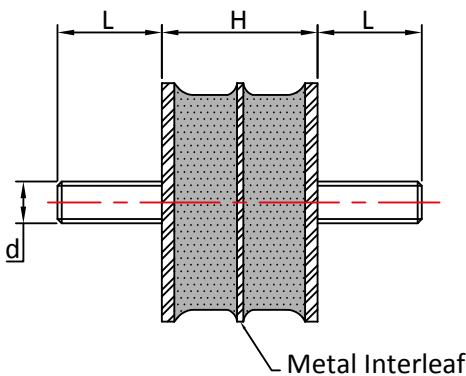

| Part No | D | H | L | d | Max Load (kg) | | | Deflection mm |
|----------|------|------|----|-----|---------------|-------------|-------------|------------------|
| | | | | | 45° Shore A | 60° Shore A | 70° Shore A | |
| IB1392 | 57 | 37 | 25 | M10 | 120 | 250 | 330 | 2.6 |
| NIB1388* | 57 | 37 | 25 | M10 | 70 | 140 | 198 | 3.0 |
| IB1393 | 76.2 | 36.6 | 25 | M10 | 230 | 580 | 810 | 3.0 |
| NIB1389* | 76.2 | 36.6 | 25 | M10 | 150 | 300 | 420 | 2.9 |

*Without Metal Interleaf

Max compression load in Kg deflection in mm.

This information is for guidance only. Customers are recommended to contact us for further technical information on products and applications. We reserve the right to alter specifications or withdraw products without notice.

Bemag Mountings



Bemag mountings are used primarily within the Construction Industry and can accommodate high dynamic forces. The oversized end metals allows for improve bonded interface between the rubber and metal to increase the fatigue life, particularly where continuous dynamic forces are applied in shear. Available with M12 threads on request.

Advantages:

- Extended Fatigue Life
- High Resilience
- Ideal for Continuous Dynamic Forces
- Cut-Outs on Metals to stop twisting

Applications:

- Vibratory Rollers
- Compactors
- Construction Equipment

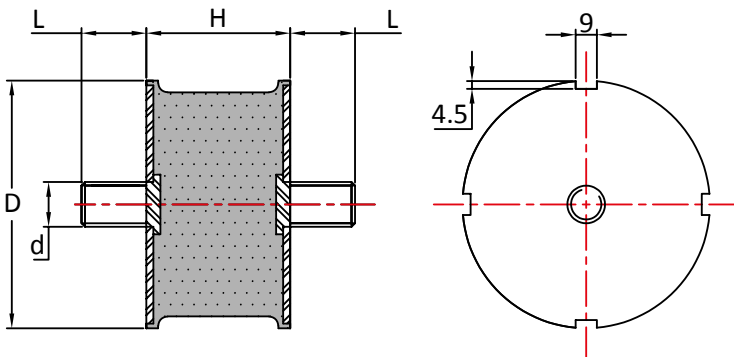

Male/Male

| Part No | D | H | d x L | d x L |
|----------------|-----|----|----------|----------|
| BM10540MM13/18 | 105 | 40 | M16 x 13 | M16 x 18 |
| BM10540MM28 | 105 | 40 | M16 x 28 | M16 x 28 |
| BM10555MM17/25 | 105 | 55 | M16 x 17 | M16 x 25 |
| BM10555MM26/15 | 105 | 55 | M16 x 26 | M16 x 15 |
| BM10555MM36/25 | 105 | 55 | M16 x 36 | M16 x 25 |

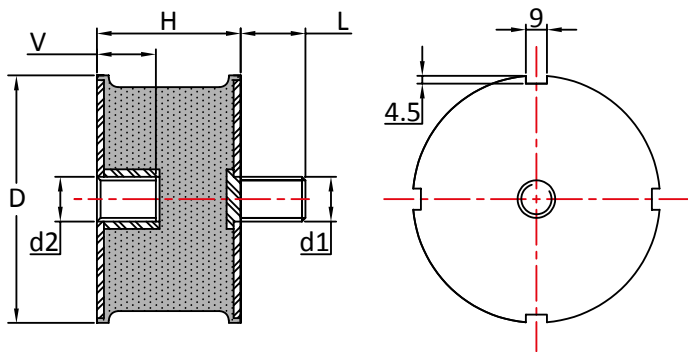

Male/Female

| Part No | D | H | d1 x L | d2 x V |
|-------------|-----|----|----------|----------|
| BM10540MF17 | 105 | 40 | M16 x 17 | M16 x 16 |
| BM10555MF17 | 105 | 55 | M16 x 17 | M16 x 16 |

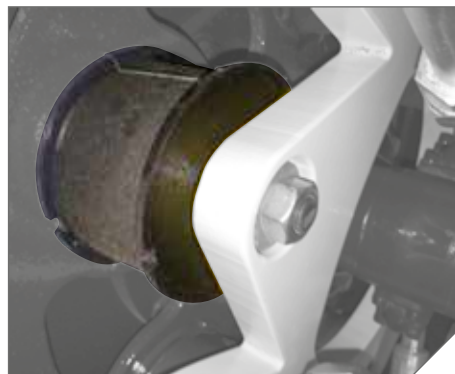

Max compression load in Kg deflection in mm.

This information is for guidance only. Customers are recommended to contact us for further technical information on products and applications. We reserve the right to alter specifications or withdraw products without notice.

Hollow Rubber Springs

Hollow Rubber Springs give high levels of deflection allowing them to provide excellent levels of shock absorption, and are available in a range of styles, sizes and rubber hardness' to suit each application. Hollow Rubber Springs are typically used as Sole Suspension Springs, Secondary Assister Springs, and Buffer & Bump Stop shock absorbers, and can be used as an alternative to a metal coil spring, where they provide the benefit of increased damping.

Advantages:

- Excellent Shock Absorption
- Progressive Stiffness
- High Fatigue Life
- Maintenance Free
- Load Ranges from 20Kg to 10600Kg

Applications:

- Vehicle Suspension Systems
- Commercial & Off-Road Vehicles
- Trailers
- Construction Equipment
- Agricultural Equipment



Max compression load in Kg deflection in mm.

This information is for guidance only. Customers are recommended to contact us for further technical information on products and applications. We reserve the right to alter specifications or withdraw products without notice.

Hollow Rubber Springs

Single Convolution

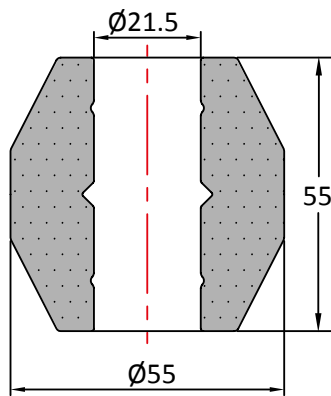

HRS5556

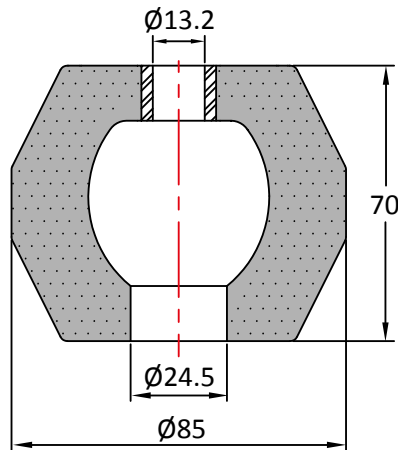

HRS170H

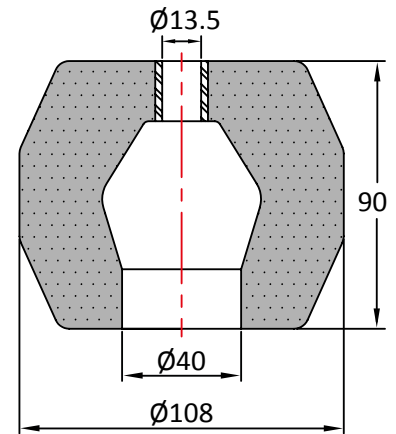

**HRS103B/1
HRS103BH**

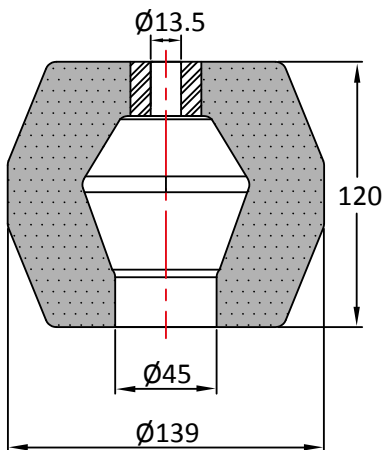

**HRS1525M
HRS1525H**

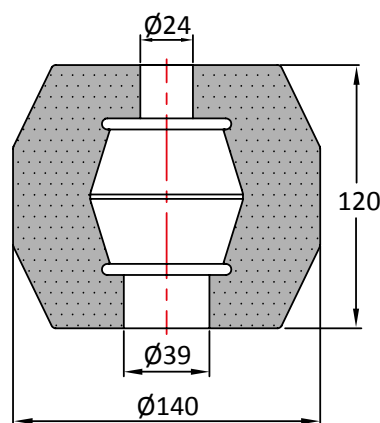

HRS140120

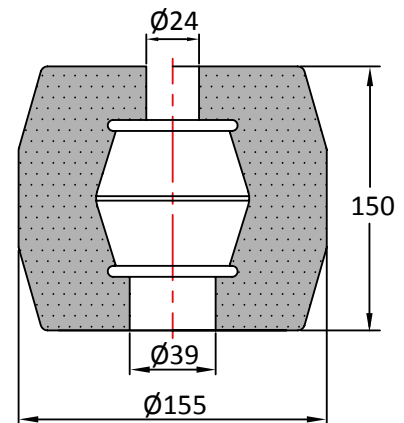

HRS155150

| Part No | Nominal Static Load (Kg) i.e. a Suspension Spring | Max Continuous Static Load (Kg) i.e. as an Assister | Max Load (Kg) Bump / Shock | Deflection at Max Load (mm) |
|-----------|--|--|-------------------------------|--------------------------------|
| HRS5556 | 110 | 300 | 500 | 32 |
| HRS170H | 250 | 1,215 | 1,820 | 42 |
| HRS103B/1 | 400 | 1,370 | 2,040 | 48 |
| HRS103BH | 500 | 1,520 | 2,270 | 41 |
| HRS1525M | 750 | 3,040 | 4,540 | 70 |
| HRS1525H | 900 | 3,040 | 4,600 | 63 |
| HRS140120 | 1,000 | 4,010 | 7,000 | 65 |
| HRS155150 | 800 | 2,500 | 3,500 | 70 |

Max compression load in Kg deflection in mm.

This information is for guidance only. Customers are recommended to contact us for further technical information on products and applications.

We reserve the right to alter specifications or withdraw products without notice.

Hollow Rubber Springs

Double Convolution

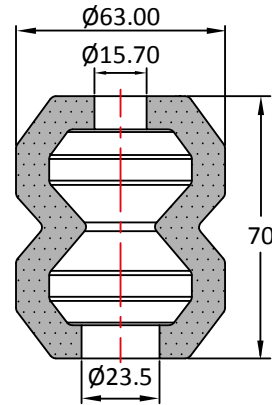

HRS505H

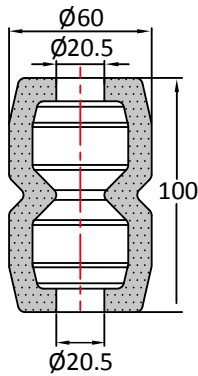

HRS10069

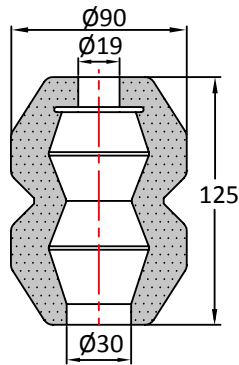

HRS90125

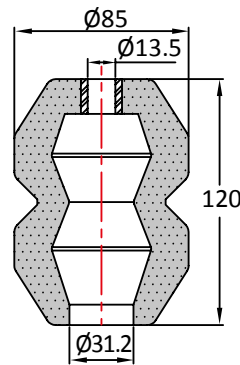

HRS530

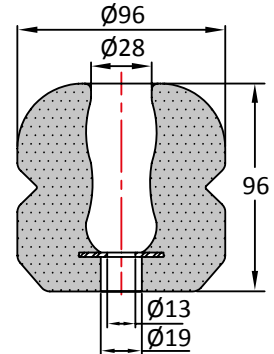

HRS9696

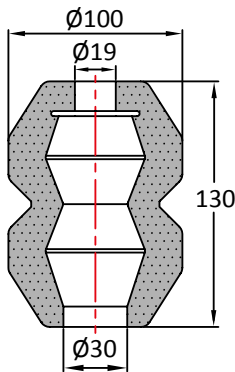

HRS100130

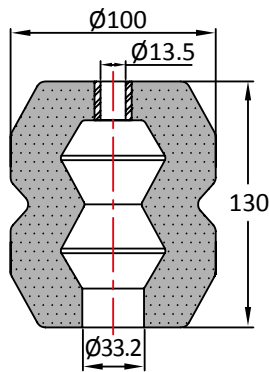

HRS535

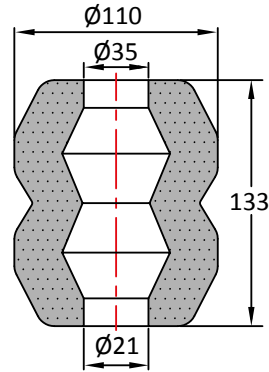

HRS110133H

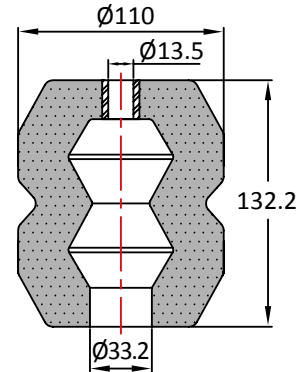

HRS540/1

| Part No | Nominal Static Load (Kg) i.e. a Suspension Spring | Max Continuous Static Load (Kg) i.e. as an Assister | Max Load (Kg) Bump / Shock | Deflection at Max Load (mm) |
|------------|--|--|-------------------------------|--------------------------------|
| HRS505H | 40 | 300 | 450 | 45 |
| HRS10069 | 120 | 600 | 850 | 58 |
| HRS90125 | 200 | 500 | 800 | 70 |
| HRS530 | 280 | 900 | 1,300 | 70 |
| HRS9696 | 300 | 1,700 | 2,400 | 50 |
| HRS100130 | 300 | 860 | 1,340 | 75 |
| HRS535 | 350 | 1,400 | 2,000 | 75 |
| HRS110133H | 450 | 2,000 | 3,000 | 75 |
| HRS540/1 | 500 | 2,300 | 3,400 | 75 |

Max compression load in Kg deflection in mm.

This information is for guidance only. Customers are recommended to contact us for further technical information on products and applications. We reserve the right to alter specifications or withdraw products without notice.

Hollow Rubber Springs

Triple Convolution and Rectangular

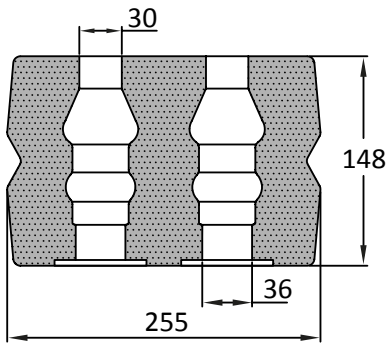

HRS225

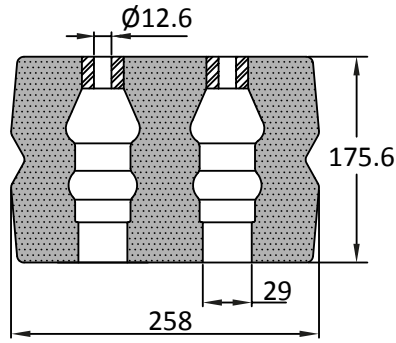

HRS260

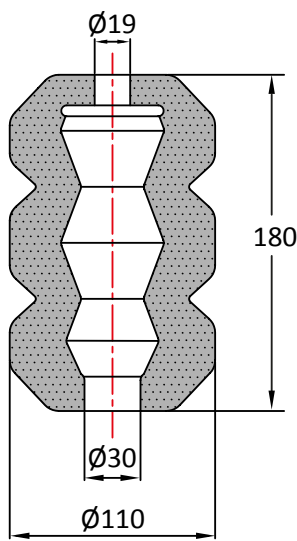
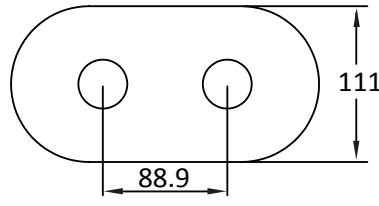
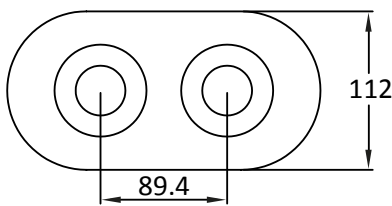

HRS110180

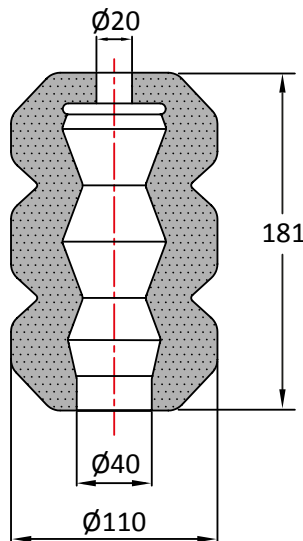

HRS110181



| Part No | Nominal Static Load (Kg) i.e. as a Suspension Spring | Max Continuous Static Load (Kg) i.e. as an Assister | Max Load (Kg) Triple and Rectangular | Deflection at Max Load (mm) |
|-----------|--|---|--------------------------------------|-----------------------------|
| HRS225 | 3500 | 10600 | 15900 | 45 |
| HRS260 | 2000 | 9500 | 16595 | 110 |
| HRS110180 | 215 | 915 | 1960 | 90 |
| HRS110181 | 300 | 1275 | 2250 | 90 |

Max compression load in Kg deflection in mm.

This information is for guidance only. Customers are recommended to contact us for further technical information on products and applications.

We reserve the right to alter specifications or withdraw products without notice.

Truck Buffers



Truck buffers are designed to absorb shock and impact forces from moving machinery parts, and to protect vehicles from damage whilst manoeuvring.

Applications:

- Commercial Vehicles
- Construction Vehicles
- Agricultural Machinery
- Trailers
- Vehicle Loading Bays

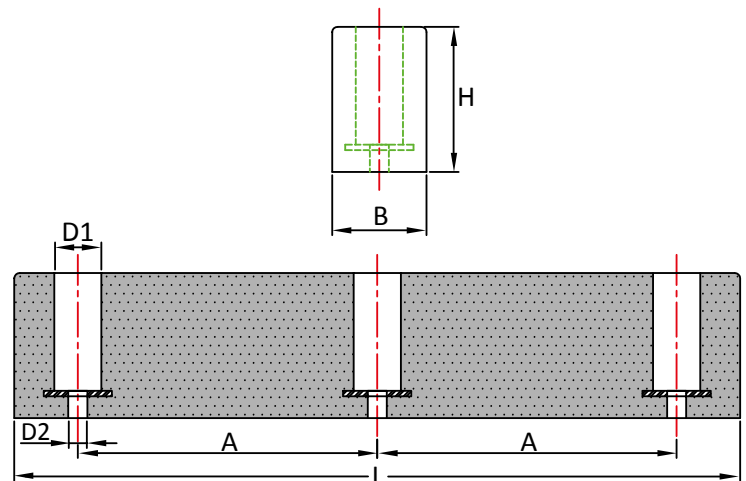
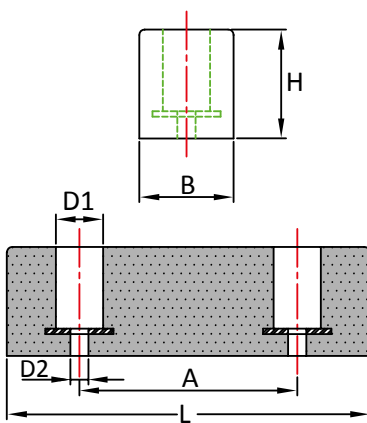
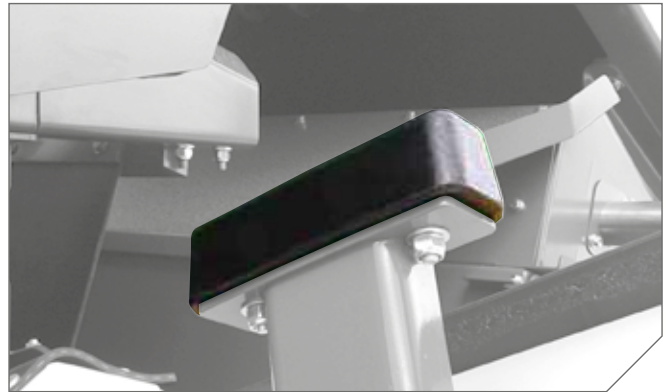

| Part No | H | L | B | Holes | A | D1 | D2 |
|---------|----|-----|----|-------|-----|----|------|
| BS-1 | 15 | 125 | 40 | 2 | 60 | 20 | 8 |
| BS-2 | 40 | 125 | 40 | 2 | 60 | 20 | 8 |
| BS-3 | 50 | 125 | 43 | 2 | 60 | 20 | 8 |
| BS-4 | 70 | 125 | 43 | 2 | 60 | 20 | 8 |
| BS-198 | 50 | 198 | 54 | 2 | 118 | 25 | 10 |
| BS-5 | 60 | 200 | 52 | 2 | 120 | 26 | 10.5 |
| BS-6 | 80 | 200 | 52 | 2 | 120 | 26 | 10.5 |
| BS-7 | 60 | 300 | 52 | 3 | 115 | 26 | 10.5 |
| BS-8 | 80 | 300 | 52 | 3 | 115 | 26 | 10.5 |
| BS-9 | 60 | 400 | 52 | 3 | 165 | 26 | 10.5 |
| BS-10 | 80 | 400 | 52 | 3 | 165 | 26 | 10.5 |
| BS-11 | 60 | 315 | 35 | 3 | 126 | 22 | 10.5 |

Max compression load in Kg deflection in mm.

This information is for guidance only. Customers are recommended to contact us for further technical information on products and applications. We reserve the right to alter specifications or withdraw products without notice.

Tipper Body Pads

Tipper Body Pads are designed to support articulated tipping vehicles bodies and trailers. They are typically used in multiples to evenly distribute the load over the chassis and also to stop metal to metal contact between the vehicle body and chassis.

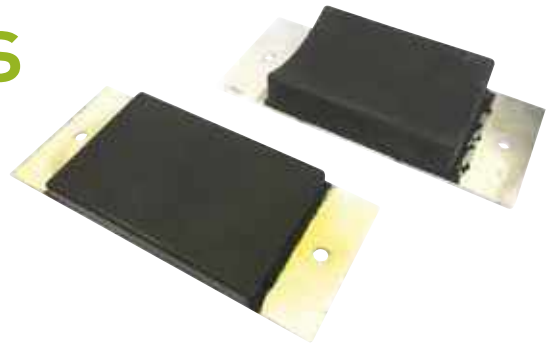

Advantages:

- Special Rubber formulation for Hostile Environments
- High Abrasion & Wear Resistance Rubber
- Aluminium or Mild Steel Plates
- Pre-Drilled Holes for ease of installation

Applications:

- Tipping Trailers (Body Pads)
- Commercial Vehicles
- Construction Equipment, ADT's & Dump Trucks
- Agricultural Equipment

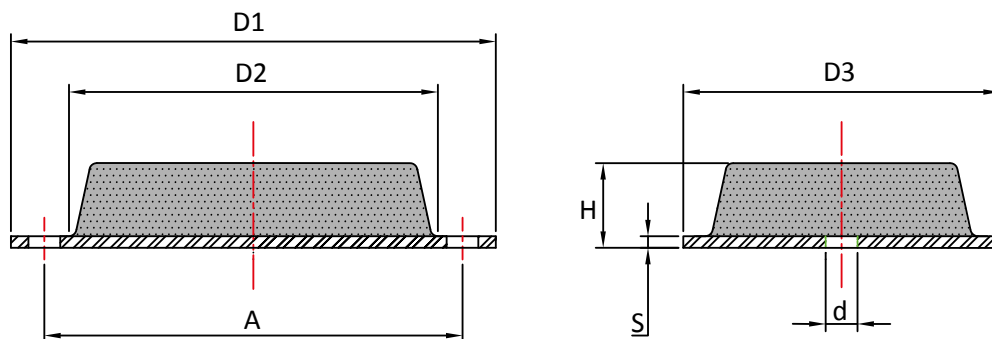
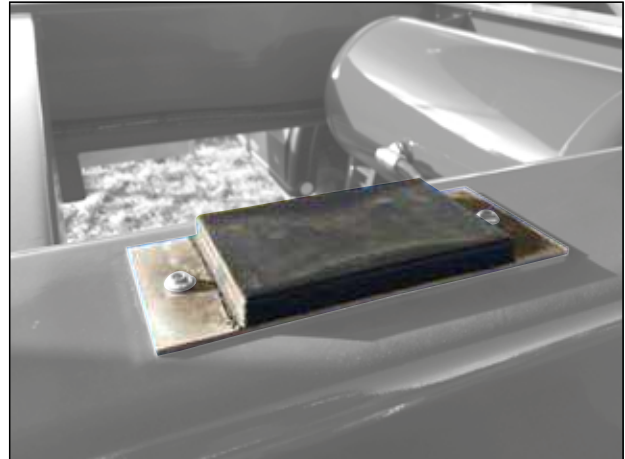

| Part No | A | H | D1 | D2 | D3 | d | S |
|---------------|-----|------|-----|-----|----|-----|---|
| PB12075-STEEL | 150 | 14 | 180 | 120 | 75 | 6.8 | 3 |
| PB1167550 | 151 | 50 | 180 | 116 | 75 | 6.8 | 4 |
| PB1137434 | 151 | 34 | 180 | 116 | 75 | 6.8 | 4 |
| PB30075-ALU* | - | 45.5 | 350 | 300 | 75 | - | 5 |
| PB28675-STEEL | - | 45.5 | 350 | 300 | 75 | - | 5 |

*Manufactured in Aluminium

Max compression load in Kg deflection in mm.

This information is for guidance only. Customers are recommended to contact us for further technical information on products and applications. We reserve the right to alter specifications or withdraw products without notice.

IOS Bushes

IOS bushes are manufactured from high quality rubber which is bonded between two concentric sleeves. Designed to allow torsional, radial and axial movement within a system, whilst also offering vibration reduction properties.

They are manufactured in such a way as to provide high durability during dynamic loads and prolonged service life. IOS bushings require no lubrication and are maintenance free.



Applications:

- Vehicle suspension
- Pivot bearings
- Mechanical linkages
- Cab mounts
- Engine mounts
- Off-road vehicles
- Military applications
- Construction Equipment

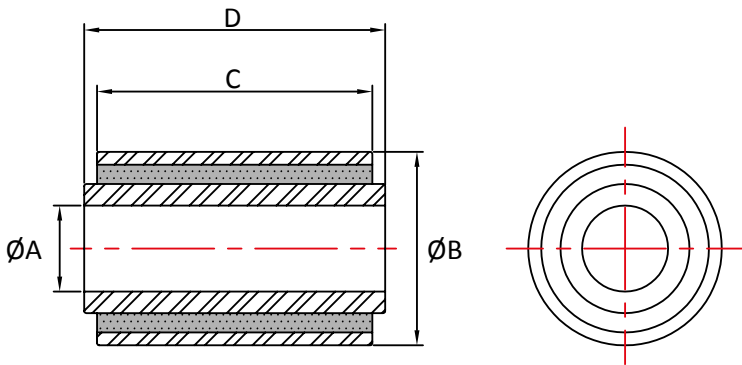

Custom Polyurethane Bushes also available

| Part No | A | B | C | D |
|-----------------|-------|-------|-------|-------|
| IOS08192830 | 8 | 19 | 28 | 30 |
| IOS10222420 | 10 | 22 | 24 | 20 |
| IOS12222528 | 12 | 22 | 25 | 28 |
| IOS1302 | 7.9 | 22.2 | 25.4 | 27.8 |
| IOS10252025 | 10 | 25 | 20 | 25 |
| IOS12252428 | 12 | 25 | 24 | 28 |
| IOS8.5262525 | 8.5 | 26 | 25 | 25 |
| IOS10273840 | 10 | 27 | 38 | 40 |
| IOS1460 | 12.7 | 28.6 | 25.4 | 28.6 |
| IOS12301718 | 12 | 30 | 17 | 18 |
| IOS12303640 | 12 | 30 | 36 | 40 |
| IOS17343934 | 17 | 34 | 39 | 34 |
| IOS15354550 | 15 | 35 | 45 | 50 |
| IOS15352530 | 15 | 35 | 25 | 30 |
| IOS20384046 | 20 | 38 | 40 | 46 |
| IOS1823 | 20.07 | 38.18 | 34.9 | 41.3 |
| IOS20406266 | 20 | 40 | 62 | 66 |
| IOS25404040 | 25 | 40 | 40 | 40 |
| IOS25403030 | 25 | 40 | 30 | 30 |
| IOS20456063 | 20 | 45 | 60 | 63 |
| IOS20454046 | 20 | 45 | 40 | 46 |
| IOS204559.562.5 | 20 | 45 | 59.5 | 62.5 |
| IOS20456470 | 20 | 45 | 64 | 70 |
| IOS16454652 | 16 | 45 | 46 | 52 |
| IOS20463542 | 20 | 46 | 35 | 42 |
| IOS0877 | 25.4 | 46.7 | 25.4 | 34.9 |
| IOS15473137 | 15 | 47 | 31 | 37 |
| IOS2847110116 | 28 | 47 | 110 | 116 |
| IOS1004 | 15.9 | 47.6 | 44.5 | 50.8 |
| IOS24506470 | 24 | 50 | 64 | 70 |
| IOS30506066 | 30 | 50 | 60 | 66 |
| IOS25503034 | 25 | 50 | 30 | 34 |
| IOS255 | 25 | 50 | 65 | 68 |
| IOS25508085 | 25 | 50 | 80 | 85 |
| IOS25504045 | 25 | 50 | 40 | 45 |
| IOS25507985 | 25 | 50 | 79 | 85 |
| IOS25506568 | 25 | 50 | 65 | 68 |
| IOS1005 | 28.58 | 54.6 | 114 | 123.8 |
| IOS15.5553016 | 15.5 | 55 | 30 | 16 |
| IOS0989 | 28.57 | 57.15 | 85.73 | 88.9 |
| IOS30606068 | 30 | 60 | 60 | 68 |
| IOS40624042 | 40 | 62 | 40 | 42 |
| IOS36626571 | 36 | 62 | 65 | 71 |
| IOS30637266 | 30 | 63 | 72 | 66 |
| IOS38648088 | 38 | 64 | 80 | 88 |
| IOS30656070 | 30 | 65 | 60 | 70 |
| IOS40658088 | 40 | 65 | 80 | 88 |
| IOS35655060 | 35 | 65 | 50 | 60 |
| IOS407112115 | 40 | 70 | 112 | 115 |
| IOS1284-70 | 44.45 | 76.2 | 76.2 | 82.55 |

Max compression load in Kg deflection in mm.

This information is for guidance only. Customers are recommended to contact us for further technical information on products and applications. We reserve the right to alter specifications or withdraw products without notice.

Eccentric Bushes



Eccentric Bushes are manufactured from two metal sleeves which are eccentrically offset in the radial direction. This offset allows for a larger proportion of the rubber section to be orientated in the normal direction of load, allowing for relatively large radial deflections to be achieved, whilst maintaining excellent motional control characteristics.

Eccentric bushes are robust in design, fail-safe, and suitable for ROPS and FOPS cabs (subject to approval).

Advantages:

- Excellent Vibration Reduction
- Robust Design – Ideal for Transit Shock
- ROPS & FOPS
- Fail Safe

Applications:

- Cab Mountings (Tilting Cabs)
- Engine Mountings
- Earth Moving Vehicles
- Agricultural Vehicles

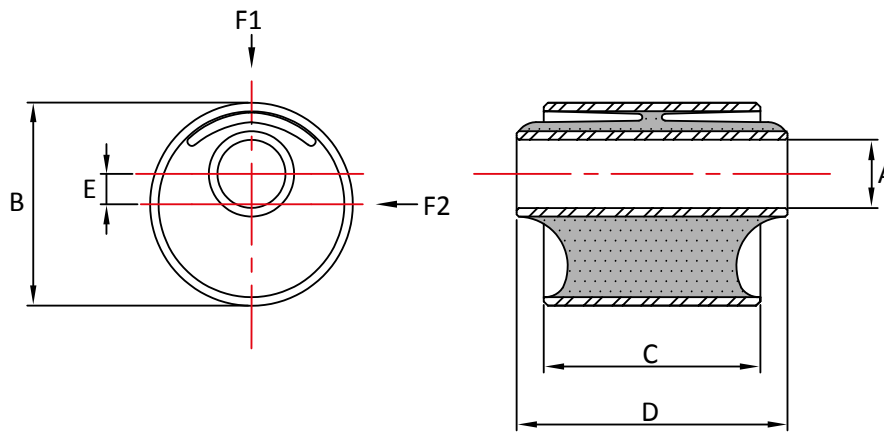

| Part No | A | B | C | D | E | F1 | | | F2 |
|------------|------|-------|------|------|------|------------------|---------------------|---------------|------------------|
| | | | | | | Stiffness (N/mm) | Max Deflection (mm) | Max Load (kg) | Stiffness (N/mm) |
| ECC1270-45 | 16 | 47.6 | 50.8 | 63.5 | 7.1 | 675 | 2 | 140 | 1350 |
| ECC1270-60 | 16 | 47.6 | 50.8 | 63.5 | 7.1 | 1040 | 2 | 215 | 2080 |
| ECC1270-75 | 16 | 47.6 | 50.8 | 63.5 | 7.1 | 1200 | 2 | 245 | 2400 |
| ECC2174-45 | 24 | 75.3 | 51.0 | 70 | 10.5 | 750 | 3.5 | 270 | 600 |
| ECC2174-60 | 24 | 75.3 | 51.0 | 70 | 10.5 | 1200 | 3.5 | 325 | 910 |
| ECC2174-75 | 24 | 75.3 | 51.0 | 70 | 10.5 | 1760 | 3.5 | 630 | 1400 |
| ECC1165-45 | 25.4 | 88.9 | 66.7 | 79.4 | 14.3 | 475 | 3.8 | 185 | 640 |
| ECC1165-60 | 25.4 | 88.9 | 66.7 | 79.4 | 14.3 | 900 | 3.8 | 350 | 990 |
| ECC1355-45 | 43.7 | 101.6 | 63.5 | 72.4 | 9.5 | 682 | 3.5 | 245 | 1150 |
| ECC1355-60 | 43.7 | 101.6 | 63.5 | 72.4 | 9.5 | 1300 | 3.5 | 465 | 2200 |

Max compression load in Kg deflection in mm.

This information is for guidance only. Customers are recommended to contact us for further technical information on products and applications. We reserve the right to alter specifications or withdraw products without notice.

Spherical Bushes

Compact and Heavy Duty flexible bearing - Spherical Bushes are able to accommodate high loads and allow movement in both the torsional and conical directions. No lubrication is required and they are completely maintenance free.



Advantages:

- High Load Capacity
- Allow Multi Axis Movement
- Reduce Stress on Assemblies
- Fail Safe Design

Applications:

- Off Road Vehicles
- Construction Equipment
- Rail applications
- Suspension Control Links
- Agricultural Equipment
- "A" frame bushes

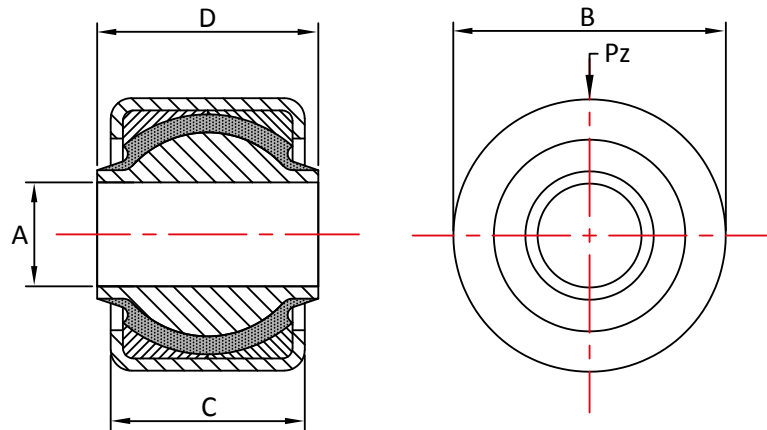

| Part No | A | B | C | D | Pz (KN) |
|---------|------|-------|------|------|---------|
| SB1316 | 25.4 | 66.7 | 48.0 | 54.2 | 34.0 |
| SB2166 | 25.4 | 66.8 | 47.6 | 54.2 | 34.0 |
| SB2201 | 25.4 | 66.7 | 47.6 | 54.0 | 34.0 |
| SB2106 | 28.6 | 90.5 | 70.0 | 76.2 | 58.0 |
| SB1285 | 38.1 | 104.8 | 76.2 | 82.6 | 80.0 |

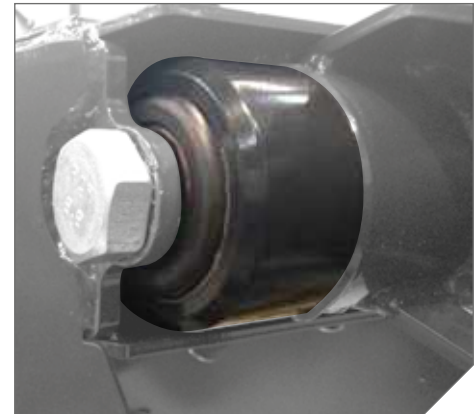

Max compression load in Kg deflection in mm.

This information is for guidance only. Customers are recommended to contact us for further technical information on products and applications. We reserve the right to alter specifications or withdraw products without notice.

Flanged Bushes



Utilising the rubber primarily in shear, Flanged Bushes have a high radial to axial stiffness ratio and are therefore ideal for controlling horizontal movement. They are a relatively stiff mounting, suitable for carrying loads of up to 1100Kg per mounting and are ideal for high frequency vibrations. Using top and bottom washers provides a fail-safe installation.

Advantages:

- Controls Horizontal Movement
- Ideal for High Frequency Vibration
- High Load Capacity
- Fail-Safe Design

Applications:

- Engines
- Vehicles
- Radiators
- Agriculture
- Construction Equipment

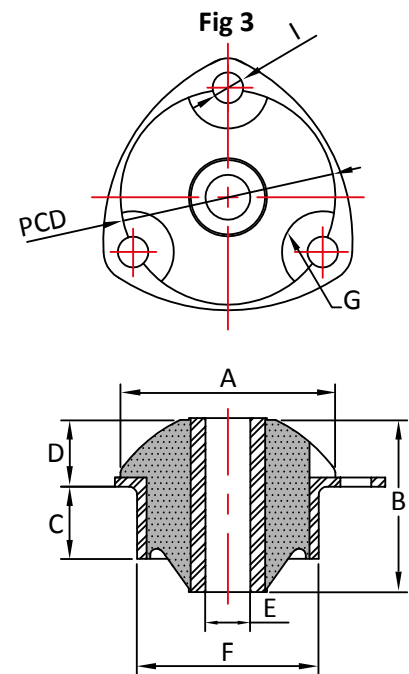
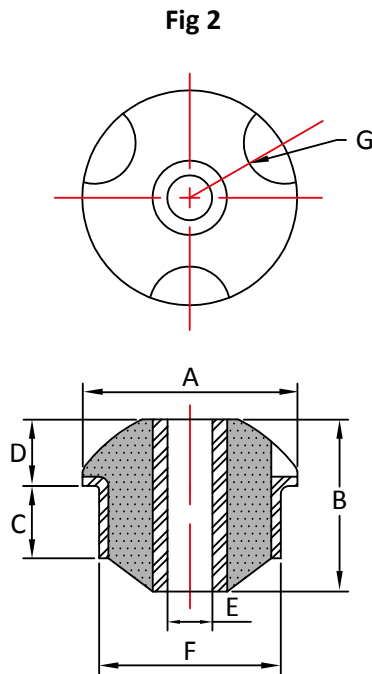
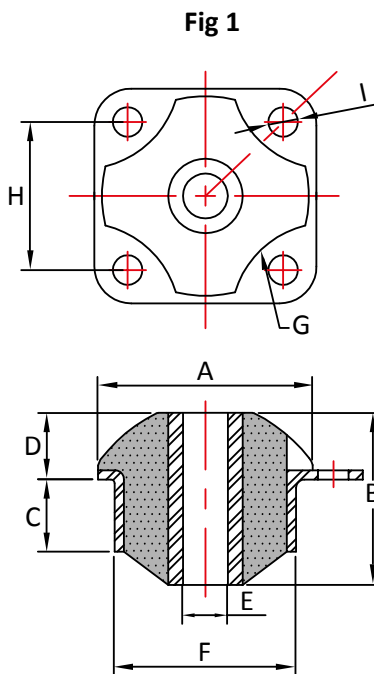

| Part No | Fig | A | B | C | D | E | F | G | H | I | PCD | 45 Shore A | | 60 Shore A | | 75 Shore A | |
|---------|-----|-----|-----|------|----|------|------|----|----|-----|-----|------------|-----|------------|-----|------------|-----|
| | | | | | | | | | | | | Kg | mm | Kg | mm | Kg | mm |
| FB00 | 1 | 36 | 28 | 12 | 11 | 8.1 | 26 | 12 | 26 | 5.2 | - | 20 | 1.5 | 30 | 1.2 | 40 | 0.8 |
| FB02 | 2 | 48 | 51 | 24 | 18 | 12.5 | 38 | 8 | - | - | - | 65 | 2.5 | 85 | 2 | 110 | 2 |
| FB20 | 2 | 70 | 55 | 27 | 19 | 18.5 | 56 | 10 | - | - | - | 100 | 3.5 | 150 | 3 | 180 | 2.5 |
| FB21 | 2 | 70 | 70 | 39 | 19 | 18.5 | 56 | 10 | - | - | - | 125 | 3.5 | 200 | 3 | 250 | 2.5 |
| FB40 | 2 | 100 | 90 | 42 | 28 | 22.5 | 74 | 19 | - | - | - | 200 | 5 | 350 | 4.5 | 400 | 3.5 |
| FB41 | 2 | 100 | 110 | 49 | 28 | 22.5 | 74 | 19 | - | - | - | 225 | 5 | 375 | 5 | 450 | 3.5 |
| FB70s | 2 | 165 | 98 | 36 | 46 | 60.2 | 119 | 22 | - | - | - | 450 | 6.5 | 800 | 5.5 | 1000 | 3.5 |
| FB70 | 2 | 165 | 140 | 66 | 46 | 60.2 | 119 | 22 | - | - | - | 450 | 6.5 | 900 | 5.5 | 1100 | 3.5 |
| FB10 | 3 | 57 | 47 | 18 | 19 | 12.1 | 49 | 11 | - | 8.2 | 69 | 70 | 4 | 100 | 3 | 120 | 2 |
| FB66 | 3 | 90 | 93 | 46.5 | 28 | 20.5 | 66.5 | 18 | - | 8.5 | 95 | 125 | 4.5 | 220 | 4 | 290 | 3.5 |

Max compression load in Kg deflection in mm.

This information is for guidance only. Customers are recommended to contact us for further technical information on products and applications. We reserve the right to alter specifications or withdraw products without notice.



INDUSTRIAL PRODUCTS

Custom and Miscellaneous

| | |
|----------------|-----|
| Jubo Couplings | 110 |
| Rubber Sheet | 111 |
| Rubber Matting | 111 |



Jubo Couplings

Jubo Couplings comprise of a polygon shaped rubber section with moulded metal inserts. After moulding of the rubber a retaining band is fitted to the Jubo Coupling to pre-compress the rubber, which is then removed, after installing onto the equipment.



Advantages:

- Reduces Driveline Vibration
- Accommodates angular misalignment
- East to Install

Applications:

- Construction & Off Road Vehicles
- Military Vehicles
- Automotive & Commercial Vehicles

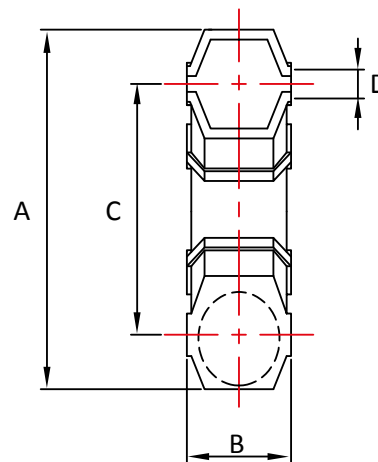
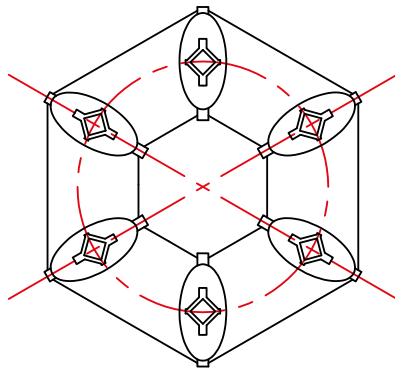

| Part No | Normal** | RPM | A | B | C* | D |
|------------|-------------|---------|-----|----|-----|----|
| | Torque Load | Maximum | | | | |
| JC220.101 | 157Nm | 4500 | 143 | 46 | 100 | 12 |
| JC220.102 | 245Nm | 3500 | 181 | 51 | 132 | 14 |
| JC220.103 | 343Nm | 3000 | 202 | 54 | 150 | 18 |
| JC220.105 | 687Nm | 2400 | 263 | 68 | 190 | 20 |
| JC220.555 | 40Nm | 6000 | 91 | 28 | 65 | 8 |
| JC220.1026 | 88Nm | 5000 | 117 | 32 | 85 | 10 |
| JC220.524 | 490Nm | 2800 | 232 | 62 | 170 | 20 |

* With Retaining Band Fitted

** Max Torque is 2.5 x Normal Torque

Max compression load in Kg deflection in mm.

This information is for guidance only. Customers are recommended to contact us for further technical information on products and applications. We reserve the right to alter specifications or withdraw products without notice.

Rubber Sheets



Plain Commercial Grade Rubber

| Part No | Thickness | Width | Roll Length |
|------------|-----------|----------|-------------|
| PCGR151410 | 1.5mm | 1.4 Mtrs | 10 Mtrs |
| PCGR301410 | 3mm | 1.4 Mtrs | 10 Mtrs |
| PCGR451410 | 4.5mm | 1.4 Mtrs | 10 Mtrs |
| PCGR601410 | 6mm | 1.4 Mtrs | 10 Mtrs |

Fabric Insertion Commercial Grade Rubber

| Part No | Thickness | Width | Roll Length |
|------------|-----------|----------|-------------|
| FICR151410 | 1.5mm | 1.4 Mtrs | 10 Mtrs |
| FICR301410 | 3mm | 1.4 Mtrs | 10 Mtrs |
| FICR451410 | 4.5mm | 1.4 Mtrs | 10 Mtrs |
| FICR601410 | 6mm | 1.4 Mtrs | 10 Mtrs |

Fine Fluted Commercial Grade Rubber

| Part No | Thickness | Width | Roll Length |
|------------|-----------|----------|-------------|
| FFCR151210 | 1.5mm | 1.2 Mtrs | 10 Mtrs |
| FFCR301210 | 3mm | 1.2 Mtrs | 10 Mtrs |

Rubber Mats

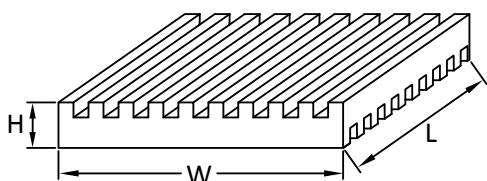

Type A (Double)

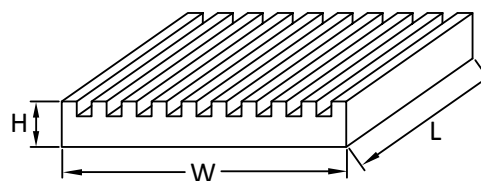

Type B (Single)

| Part No | Type | mm | | | Max Load Per Mat (Kg) |
|---------|------|-----|-----|----|-----------------------|
| | | W | L | H | |
| M100100 | A | 100 | 100 | 8 | 200 |
| M300300 | A | 300 | 300 | 8 | 1700 |
| M400400 | B | 400 | 400 | 12 | 3500 |
| M600500 | A | 600 | 500 | 8 | 15000 |

Mats can be supplied in oil resistant rubber on request

Max compression load in Kg deflection in mm.

This information is for guidance only. Customers are recommended to contact us for further technical information on products and applications. We reserve the right to alter specifications or withdraw products without notice.



INDUSTRIAL PRODUCTS

Notes



Engineering Services

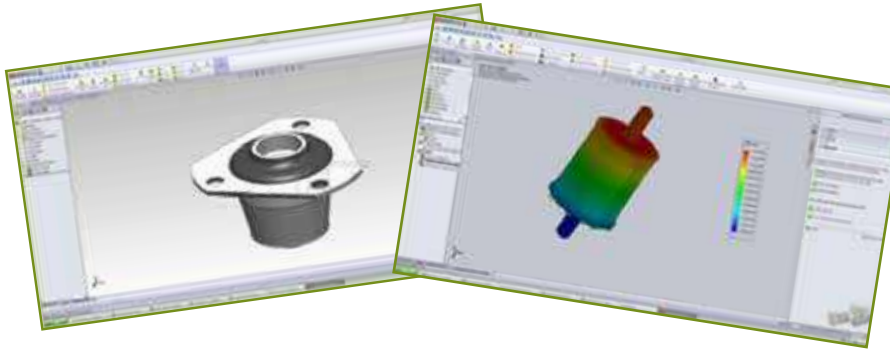

Product Design and Computer Modelling

Our team of highly qualified & experienced application engineers use state of the art computer modelling software to ensure that the best solution is found for your application. Using the latest computer modelling software, we can design and test new products, meaning we can offer you the ideal mounting for your application.

Product Verification & Testing

Using our extensive in-house testing facilities, we can ensure that every product conforms to our high standards. Including mechanical testing, rubber properties and performance characteristics.



Vibration Surveys & Frequency Analysis

Using the latest & top of the range vibration analysis equipment, our dedicated team of application engineers are at hand to offer our customers a complete comprehensive survey. Using the data we gather at your site, we can offer in depth detailed reports with mounting recommendations for your applications.

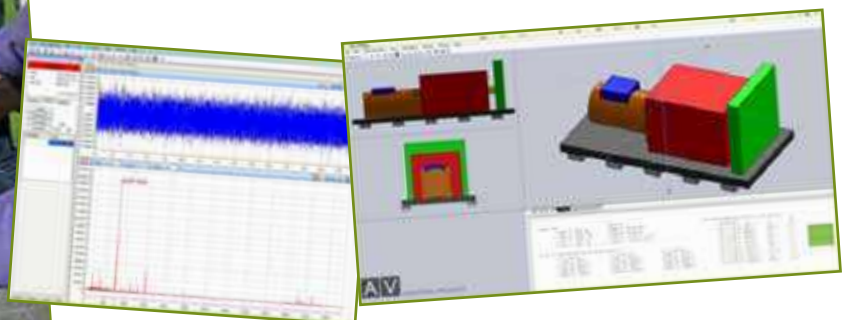

Specialists in Anti-Vibration Mountings and Rubber Engineering Components

Next day delivery service from stock

Whether the need is a 'one off' installation or for high volume scheduled deliveries, you can put your mind at rest.

Wide range of products

An extensive range of mountings are available from stock to suit loads of 1kg to 5 tonnes per mount.

Free technical advice

For design and mounting solutions.

Custom made all rubber & rubber bonding components

For all pre production and prototype work up to full scale production.

Competitiveness

Unbeatable value and prices



INDUSTRIAL PRODUCTS

Acoustiguard - WILREP LTD.

T: 905-625-8944

TOLL FREE: 1-888-625-8944

E: info@wilrep.com

www.acoustiguard.com