



Novibra® type RAEM

For effective isolation of vibration and noise on machines with rotating movements, e.g.

- Compressors
- AC units
- Industrial fans
- Generators
- Combustion engines
- Emergency power sets
- Large milling machinery
- Industrial and marine gen sets
- Refiners
- Defibrators

Features

RAEM is a universal mounting for applications demanding maximum isolation. It is a further development of RA, where EM stands for “extra soft”. Suitable for both light and heavy machines.

For normal speeds of approx. 1500 rpm the RAEM type provides a degree of isolation of 85-95%, and gives good isolation with low frequency machines.

Its unique construction and the latest production methods make Novibra type RAEM a high performance mounting having a number of advantages:

- Rubber features are utilised effectively combining compression and shear.
- Wide load rating options, 10-3400 kg.
- Corrosion protected to cope with arduous environments on land or marine applications (Fe/Zn8C as per ISO 2081).
- Fitted as standard with an integral fail-safe design with resilient stop, making RAEM ideal for use on mobile or marine applications. The RAEM mounts can accommodate occasional shock loads to 5 g reference to the weight in hardness 60° IRH. The mount will withstand shock loads up to 2 g without plastic deformation.
- Clear and durable product marking so that mountings can be identified even after several years in operation.
- Domed shape cover to protect against oil contamination.

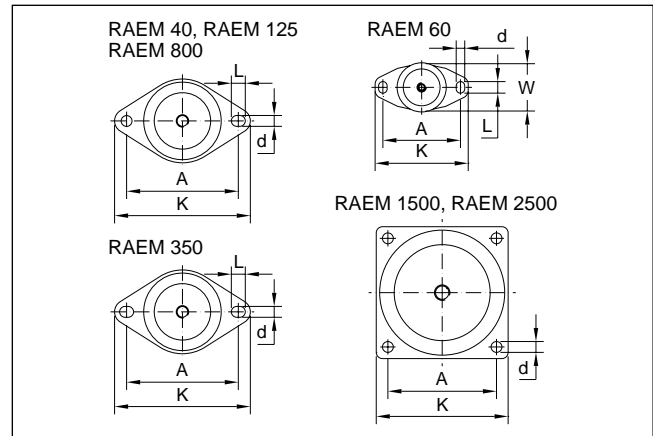
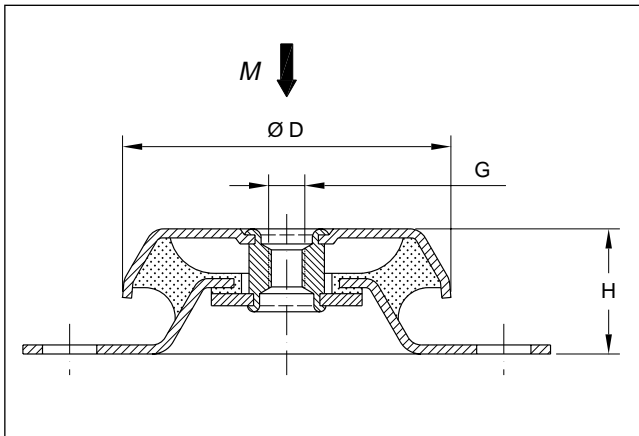

Type	Art.No. 40° IRH	Art.No. 60° IRH	Dimensions in mm							Weight (kg)	M-Max(kg)		
			D	A	W	H	K	d	L		G	40° IRH	60° IRH
RAEM 40	1861860	1861870	64	88		35.5	110	9	12	M10	0.26	30	60
RAEM 60	2256760	2256770	63	100	61	35.5	120	11	15	M12	0.30	60	120
RAEM 125 M10	1861720	1861730	84	110		35.5	135	11	15	M10	0.37	80	180
RAEM 125 M12	2256140	2256150	84	110		35.5	135	11	15	M12	0.37	80	180
RAEM 350 M12	2256440	2256450	110	140-148		42	175	14	18	M12	0.80	200	400
RAEM 350 M16	1861780	1861790	110	140-148		42	175	14	18	M16	0.80	200	400
RAEM 800	1861840	1861850	155	182		54	216	14	18	M16	1.8	450	800
RAEM 1500	2255400	2255410	182	146		85	180	14		M20	3.0	900	1700
RAEM 2500	2255420	2255430	224	180		105.5	220	17.5		M24	4.6	1700	3400

Note: The natural frequencies and degrees of isolation are based on dynamic characteristics of the mountings.

Load per mounting (kg)

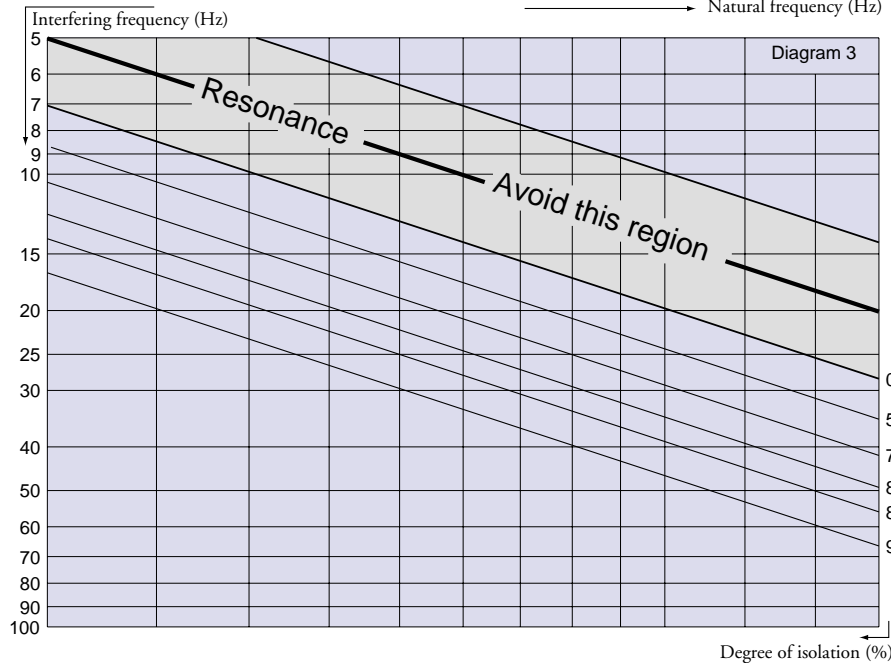
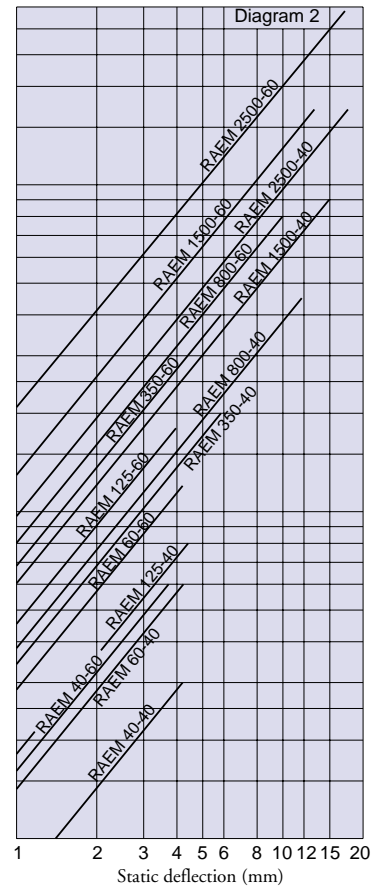
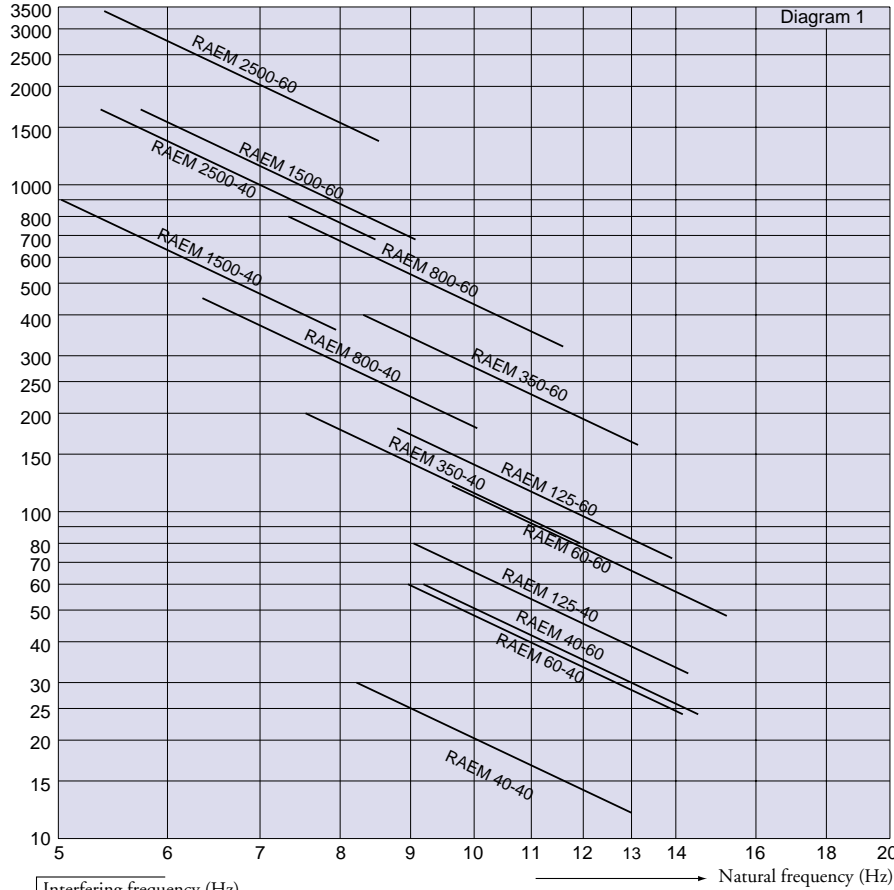

To select correct mounting, following data are needed:
 1) Load per mounting (kg)
 2) Interfering frequency (Hz) (Hz = rpm / 60)
 Select correct load line in diagram 1 and correct interference line in diagram 3. The load line intersects with required type of mounting. Connect this intersection point vertically down to the interference line in diagram 3. Here, on the sloping curve, the isolation degree is indicated. For static deflection, see diagram 2.

